

CONF-840383--2

Los Alamos National Laboratory is operated by the University of California for the United States Department of Energy under contract W-7405-ENG-36.

LA-UR--84-392

DE84 009611

TITLE: ON THE DESIGN OF EXPLOSIVE LOGIC ELEMENTS

AUTHOR(S): W. H. Meyers

SUBMITTED TO: 12th Symposium on Explosives and Pyrotechnics
San Diego, California
March 13-15, 1984

MASTER

DISCLAIMER

This report was prepared as an account of work sponsored by an agency of the United States Government. Neither the United States Government nor any agency thereof, nor any of their employees, makes any warranty, express or implied, or assumes any legal liability or responsibility for the accuracy, completeness, or usefulness of any information, apparatus, product, or process disclosed, or represents that its use would not infringe privately owned rights. Reference herein to any specific commercial product, process, or service by trade name, trademark, manufacturer, or otherwise does not necessarily constitute or imply its endorsement, recommendation, or favoring by the United States Government or any agency thereof. The views and opinions of authors expressed herein do not necessarily state or reflect those of the United States Government or any agency thereof.

By acceptance of this article, the publisher recognizes that the U.S. Government retains a nonexclusive, royalty-free license to publish or reproduce the published form of this contribution, or to allow others to do so, for U.S. Government purposes.

The Los Alamos National Laboratory requests that the publisher identify this article as work performed under the auspices of the U.S. Department of Energy.

DISTRIBUTION OF THIS DOCUMENT IS UNLIMITED

 Los Alamos National Laboratory
Los Alamos, New Mexico 87545

ON THE DESIGN
OF
EXPLOSIVE LOGIC ELEMENTS

by

W. H. Meyers
Project Manager
Detonation Systems Development
Los Alamos National Laboratory

INTRODUCTION

Los Alamos has been exploring explosive logic systems to see if they might provide advantages in weapon safety or weapon command and control. We use the extrudable explosive EXTEX (80% PETN, 20% Sylgard) for this work. These systems contain at least one but usually several discrete logic elements, and the worth - the reliability - of the system is directly dependent on the reliability of these elements. We perceive that the troubles encountered in the early attempts to use explosive logic can be attributed to the lack of a truly reliable design for one or more of the elements being used. At Los Alamos, we express this as the need for a Safety/Reliability Window. In this short presentation, that concept will be emphasized. The development of three elements for which working windows are available will be discussed.

THE SAFETY/RELIABILITY WINDOW

We define the Safety/Reliability Window as shown in Fig. 1. Careful consideration of the statement will bring out these points:

- 1) there are two probability functions;
- 2) they are the result of two different situations; and
- 3) the two probabilities must not overlap under all tolerance, material, and environmental conditions.

SAFETY/RELIABILITY WINDOW

The region in which the probability of function in the desired mode (stimulus) is high while the probability of function in an undesired mode (stimulus) is low.

A useful logic has a window wide enough to allow for production tolerances and material variations.

Figure 2 shows the window in a situation in which it is desirable to fire across the gap in one direction but undesirable to fire across in another. Consider first the undesirable, and begin with a zero gap. The probability of firing across the gap is then 1.0, but increasing the gap will eventually bring about a drop in that probability to zero. Now consider the desirable function but begin with a very large gap, such that the probability is manifestly zero. Reducing that gap will eventually bring about an increase in the probability.

The Safety/Reliability Window can now be seen. It is the range over which the probability of the desired event is high while the probability of the undesired event is low. We use the two values of 0.999 and 0.001 to define our windows.

Figure 3 shows a variety of logic elements, to permit further discussion of the window. The corner-turning element is simple in concept. In one direction detonation will proceed along the gentle curve - the desired function. In the other direction, it is undesirable for the detonation to make the sharp turn into the gentle curve. This element may not appear to have a gap. It really does, and this is the problem with it. When the radius of curvature is made large enough to be sure the turn back does not happen, there is some chance that shock from the right-hand track will simply reinitiate the curving track. We believe a working window is not possible with this element. The next element is interesting but perhaps not very practical. By varying the amount of PETN in the explosive, one can, in principal, find a good window. The large/small device would appear to have a window, but in our limited tries we did not find one. The flying-plate element makes use of the acceleration of the plate across a space to assure the desired function. In the other direction, the plate and the space are barriers to crossing the gap. As shown later, we have developed a unit of this type.

The interrupted track element, NULL gate, works by simply breaking the signal line. If the end of the NULL line is too close to the signal track, it can detonate the track, causing the undesired effect. If it is too far from the signal track, it fails to prevent passage of the signal. In our work, we found that a good window was available when a space was provided into which the signal line could be moved by the NULL gate.

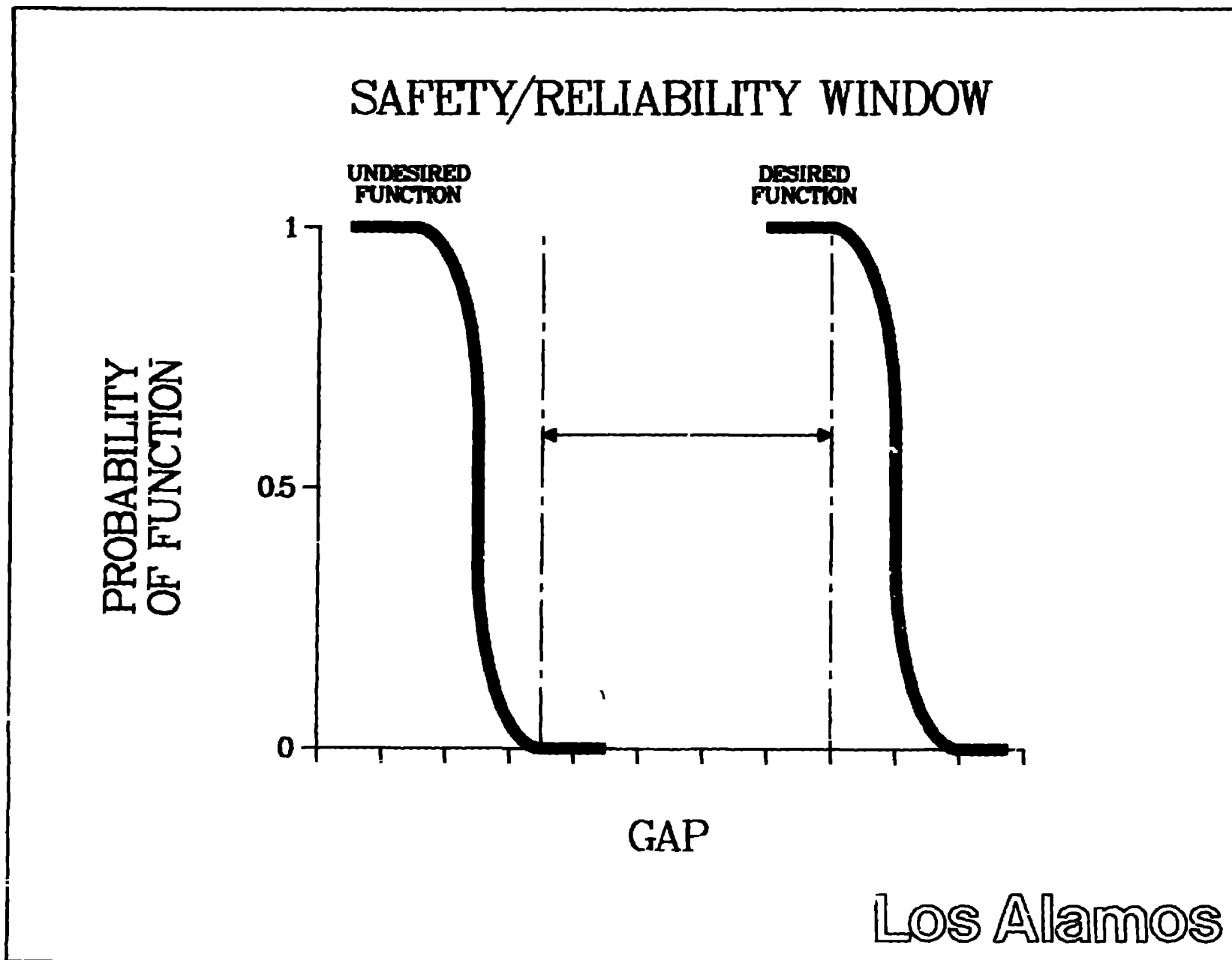

FIG. 2

SOME LOGIC ELEMENTS

CORNER TURNING



VARIED SENSITIVITY



LARGE/SMALL



FLYING PLATE



INTERRUPTED TRACK

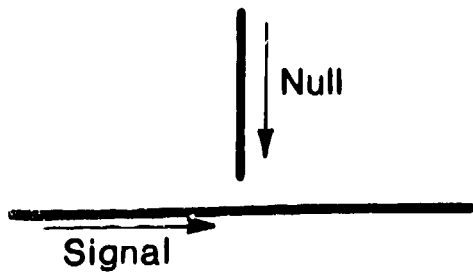

AND GATE

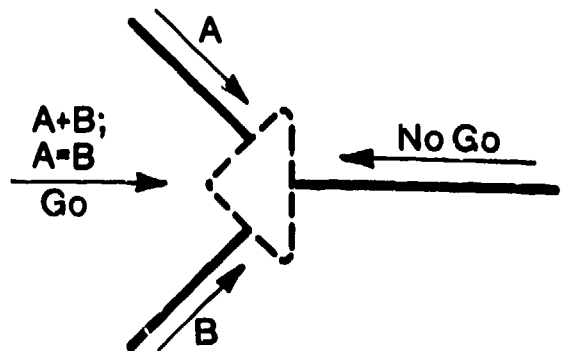

The AND gate element shown here requires not only two signals - two detonations - to come into a small block of aluminum, but an additional requirement is that the two be well-timed so the two shock fronts coincide in the block to produce a high-pressure Mach stem, setting off the downstream track. We call this type a coincidence gate. We have developed a simpler gate of this type, as will be shown later.

DEVELOPMENT OF THREE LOGIC ELEMENTS

We have developed three logic elements to the point we are confident they have useful windows. They are shown schematically in Fig. 4.

NULL GATE DEVELOPMENT

Most of our NULL gate design work was done in a geometry shown in Fig. 5. The signal track is on the far side of a Lexan plate; the NULL line is on the near side. The round button extends toward the signal line but is separated from it by a known thickness of Lexan - the gap.

In addition to wanting to establish the gap window, we wanted to learn the function time for a NULL gate. That is, when must the NULL line fire, relative to the detonation in the signal track to be sure that the signal is stopped. Knowing this value allows a rapid response system to be designed. We combined these two considerations in the test piece shown in Fig. 6. Each test had the same gap thickness. Detonator A could be positioned at different points in order to change the relative timing of the NULL gates to the signal line. By iteration of each gap situation a sufficient number of times, the gap probability could be developed along with the function time statistics.

Our test results are summarized as follows:

<u>GAP</u>	<u>RESULTS</u>
0.25 mm	Function time $< 0.3 \mu\text{s}$, but signal track was initiated in 2 of 40 trials.
0.50 mm	Function time $0.3 \mu\text{s}$ with sigmas of $0.06 \mu\text{s}$. No cross fires in 50 trials.
0.75 mm	Function time $1.13 \mu\text{s}$ with sigmas of $0.06 \mu\text{s}$ but one spot nulled in $0.6 \mu\text{s}$. No cross fires.
1.00 mm	Function time over $1.5 \mu\text{s}$.

If the function time is of no concern, we found that nulling can be accomplished with gaps as large as 1.5 mm, if there is space provided for moving

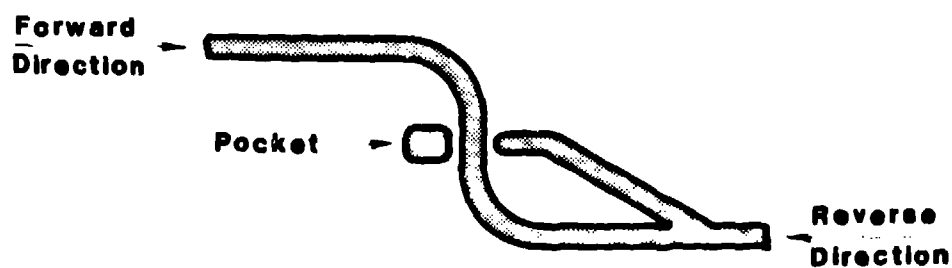

NULL GATE DIODE

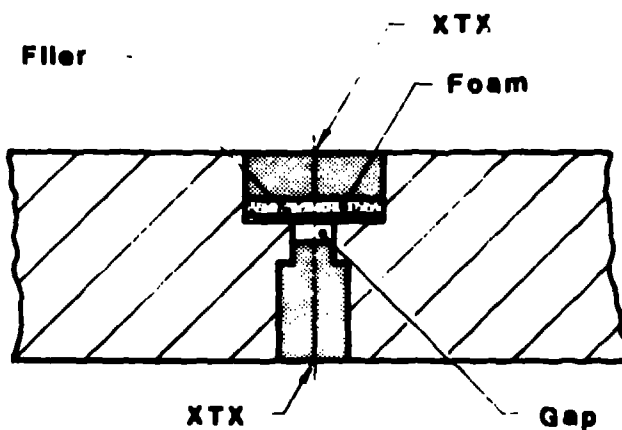

FLYING PLATE DIODE

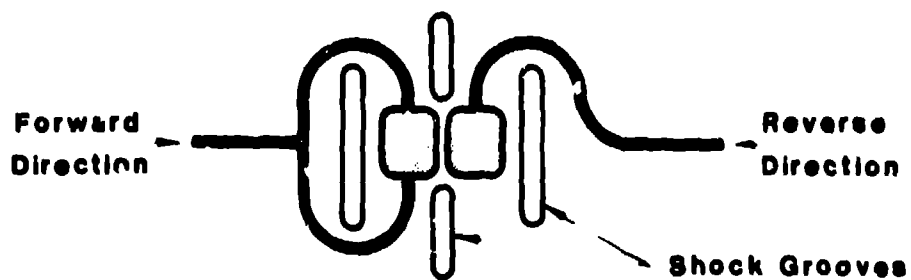

COINCIDENCE GATE DIODE

ANNUAL SCIENTIFIC LECTURE
THE UNIVERSITY OF CALIFORNIA

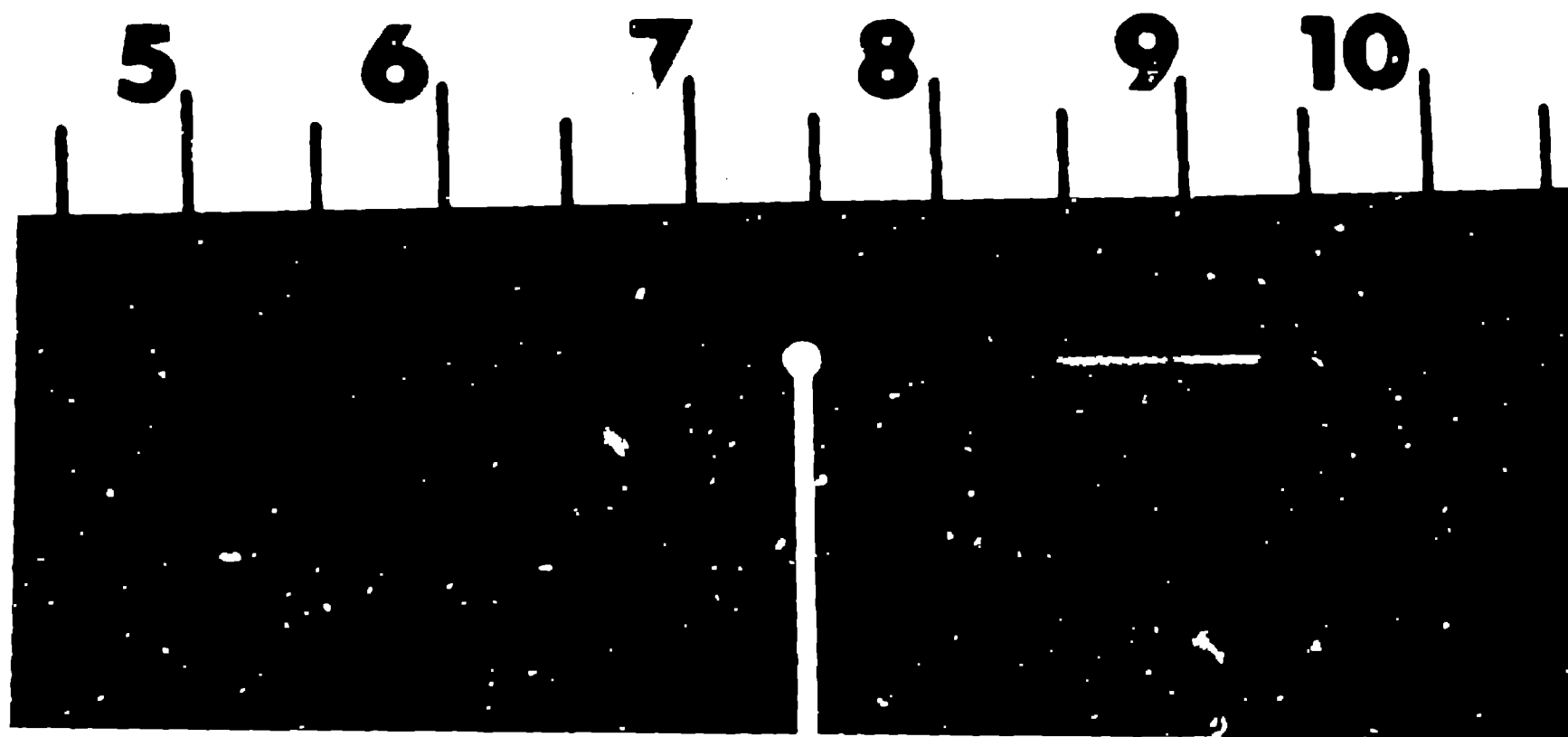

FIG. 5

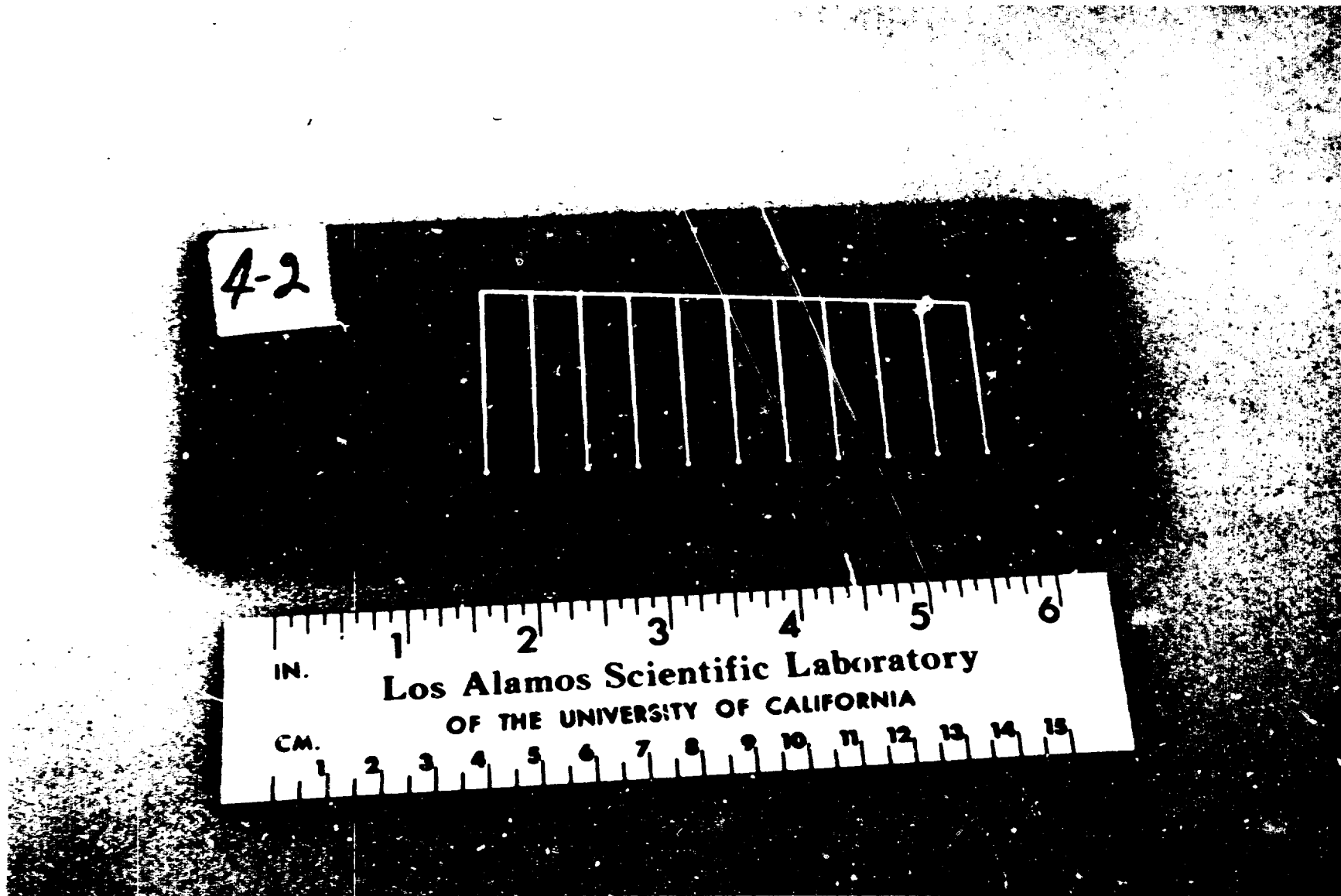

FIG. 6

the track. We observed that in the short gap situations, nulling actually was accomplished by the high pressure from the NULL line, before any movement of the track occurred.

FLYING-PLATE DIODE DEVELOPMENT

We have not made an extensive study of the flying-plate diode. It is presented because we believe it has a good working window and because it represents a way of controlling the transfer of detonation from one side of a plate to another. The schematic (Fig. 4) does not show it, but we have made this gate into a small steel piece that, we believe, could be machine-loaded in standard ammunition loading machines and then set into a plate. Note particularly the use of foam behind the flyer. Since the detonation in the reverse direction is directly toward the flyer, we could not find a window until we added the foam piece. The Safety/Reliability in this case is expressible in terms of the thickness of the foam, but we have not done enough work to express it quantitatively.

COINCIDENCE GATE DEVELOPMENT

The coincidence gate is the most thoroughly characterized of the three elements. In the beginning, we used the simple arrangement shown in Fig. 7. Figure 8 shows the sharply defined collision line marked in a witness plate under one of these shots. We used two EBWs in each test. This round-to-round gate was used because we thought it might be useful to have pellets of some other explosive than EXTEX in the donor and acceptor. We soon found, however, that the use of pellets gave inconsistent performance because the pellets did not fit the cavity perfectly. With EXTEX extruded into the donor and acceptor cavities, there are no clearances and the performance is quite consistent. This also allowed us to think about other geometries. As shown in Fig. 9, we evolved to a rectangular geometry. At this point, we asked the development group at Mound (operated by Monsanto Research for DOE, Miamisburg, Ohio) to make a parameter study and to obtain good statistics for the Safety/Reliability Window for a range of parameters.

Figure 10 shows the parameters in the coincidence gate. Mound varied the length (l) in three steps: 0.062, 0.099, and 0.136 in. Three depths (d) were used: 0.063, 0.092, and 0.121. Three thicknesses (t) were used: 0.031, 0.050, and 0.070. Figure 11 shows the 13 different configurations used in Mound's tests.



FIG. 7

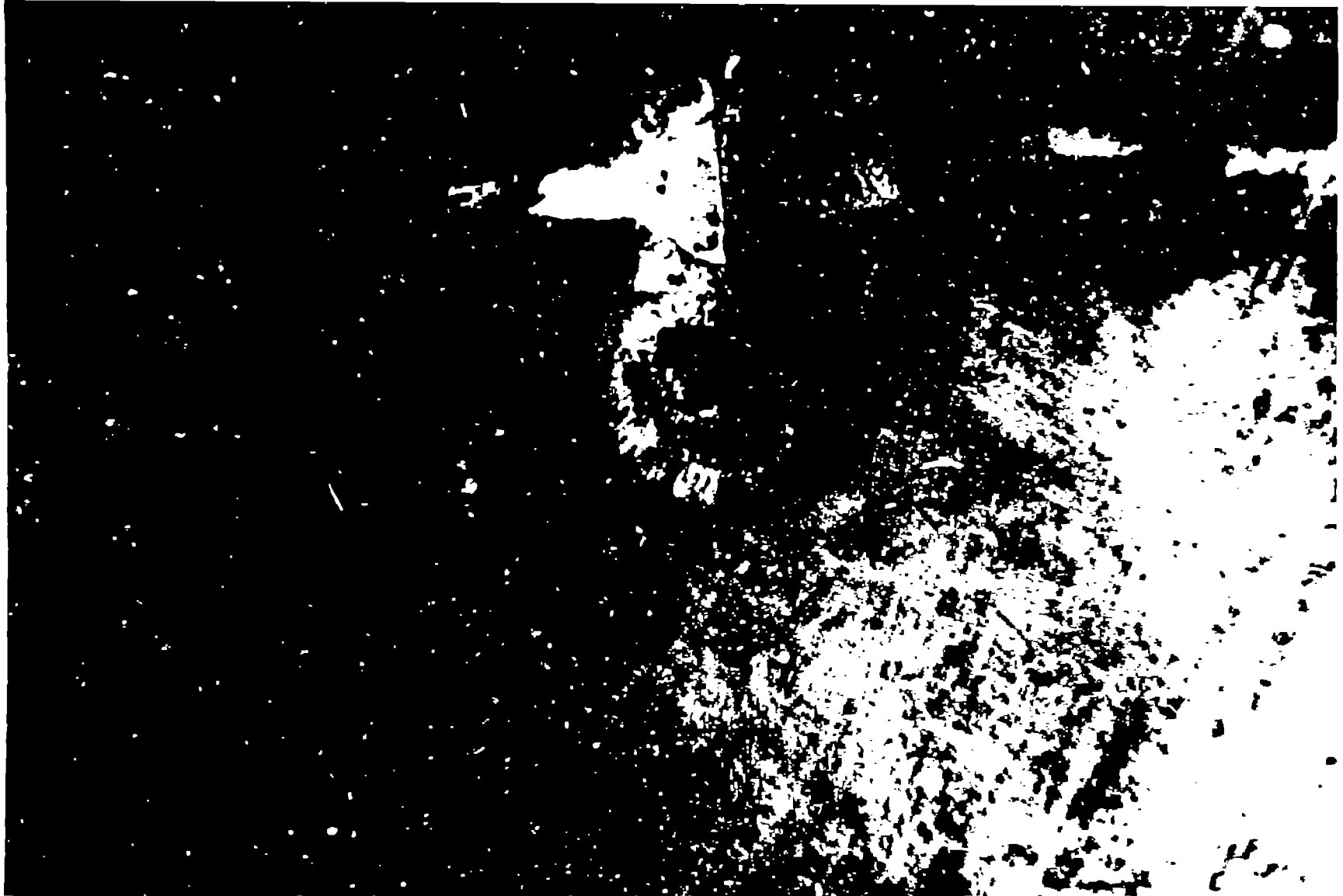
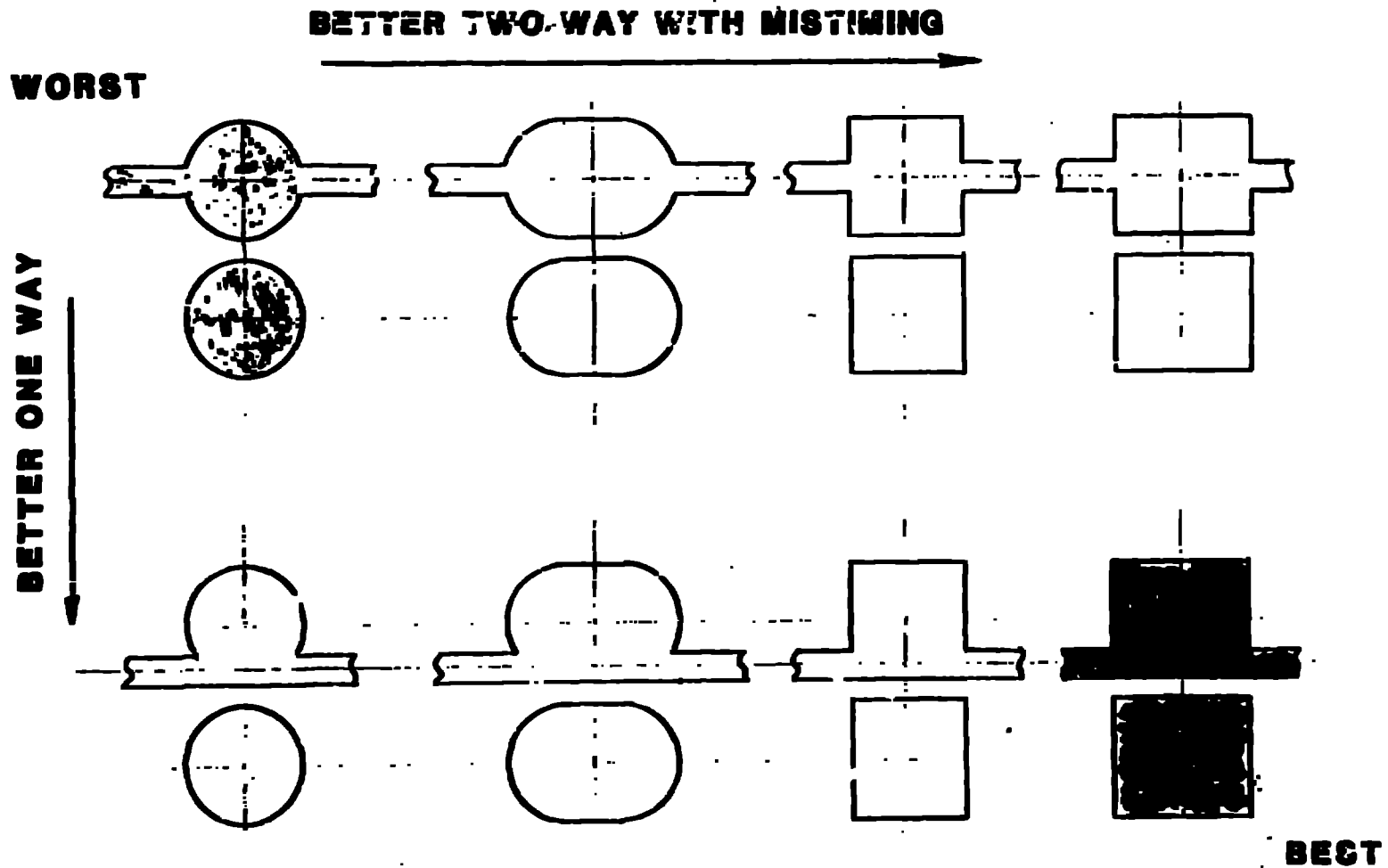

FIG. 8

COINCIDENCE GATE GEOMETRIES



Los Alamos

Los Alamos National Laboratory Operated by University of California

FIG. 9

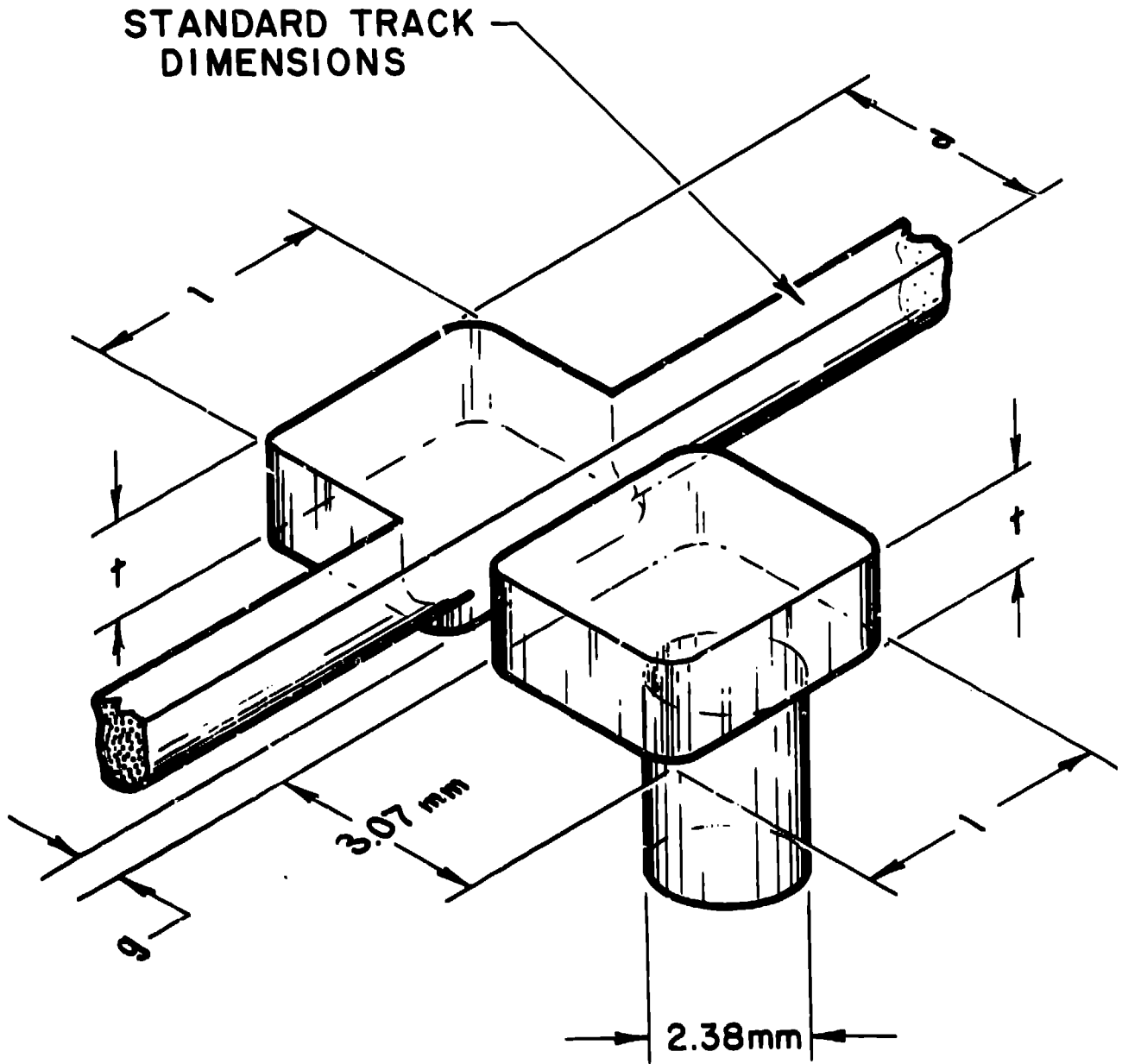

LOGIC ELEMENT PARAMETERS

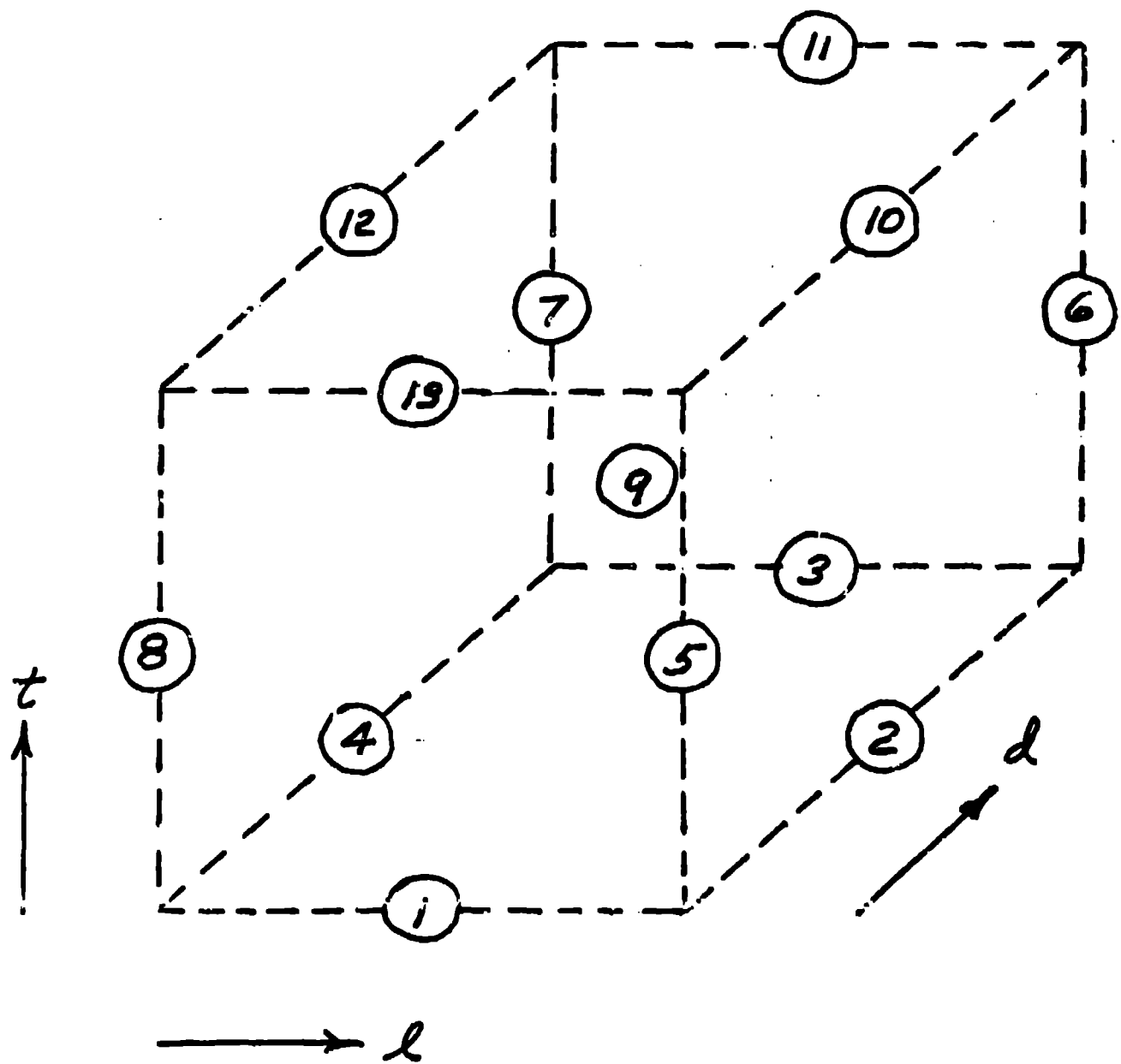

Coincidence Gate

Parameter Study

The one-way probability study was performed at +95°C. The two-way probability study was done at -56°C. Several batches of EXTEX were included in the test. No significant differences were seen between batches.

Mound devised a test piece in which one detonator would initiate a track system leading to eight gates. The gap thickness in each of the eight gates was varied in small steps such that firing of the acceptor was expected in some of the gates. By repeated testing, a statistical statement was obtained for each gate configuration.

The one-way test series did not yield statistical information simply because the smallest gap that could be machined (6.0 mil) resulted in no fires in every trial, as did the larger gaps used in the one-way test. We think a conservative estimate is that a gap of 8.0 mil has a 0.001 probability of permitting firing of the acceptor.

The two-way series yielded very good data. The thicknesses of the elements was found to affect the results very strongly. The thinnest configurations all had 0.999 probabilities in the neighborhood of 8.0-mil gap (i.e., there was no window). Increasing the thickness shows significant improvement. The other parameters showed only small changes over the range of this experiment. Figure 12 shows the location of the probability line for the best configuration: $l = 0.136$; $d = 0.092$; and $t = 0.070$. The 0.999 gap is 24.2 mil, showing a Safety/Reliability Window of 0.016 mil.

In production, we would anticipate molding the gate. Molding could be expected to hold a very tight tolerance on the gap, if sufficient attention is given to marking the mold cavities. We would expect, however, to encounter occasional voids or other flaws that would tend to reduce the effective gap. For this reason, we would tend to use a design gap located not in the middle of the window but instead located closer to the 0.999 point.

SAFETY/RELIABILITY WINDOW

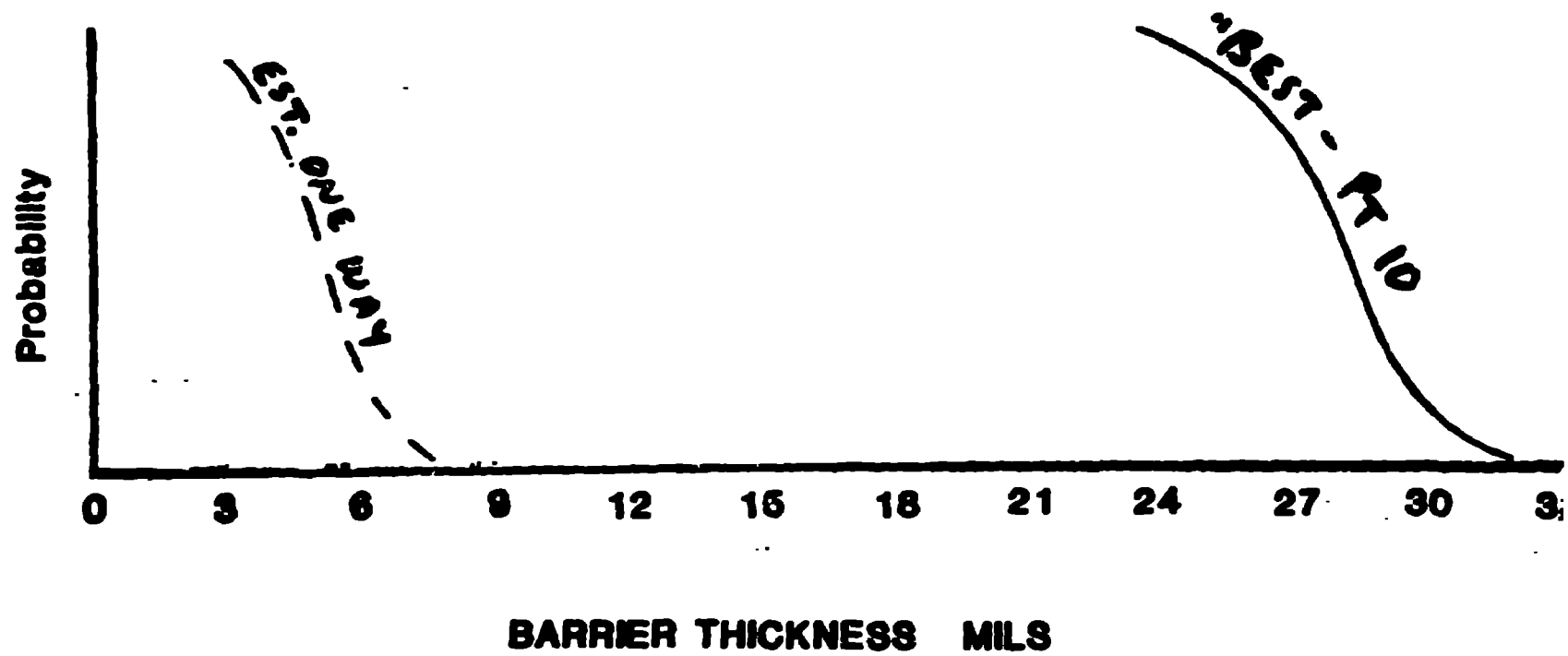

FIG. 12