

MASTER

TITLE: FUSION POWER FROM FAST IMPLoding LINERS

CONF: 771056--4

AUTHOR(S): R. A. Krakowski, R. W. Moses, R. L. Miller,
R. A. Gerwin

SUBMITTED TO: International Atomic Energy Agency
Conference and Workshop on Fusion
Reactor Design held October 10-21,
1977, in Madison, Wisconsin

By acceptance of this article for publication, the publisher recognizes the Government's (license) rights in any copyright and the Government and its authorized representatives have unrestricted right to reproduce in whole or in part said article under any copyright secured by the publisher.

The Los Alamos Scientific Laboratory requests that the publisher identify this article as work performed under the auspices of the USERDA.



An Affirmative Action/Equal Opportunity Employer

FUSION POWER FROM FAST IMPLODING LINERS

R.A. KRAKOWSKI, R.W. MOSES
R.L. MILLER, R.A. GERWIN
Los Alamos Scientific Laboratory
University of California
Los Alamos, NM
United States of America

NOTICE
This report was prepared as an account of work sponsored by the United States Government. Neither the United States nor the United States Department of Energy, nor any of their employees, nor any of their contractors, subcontractors, or their employees, make any warranty, express or implied, or assume any legal liability or responsibility for the accuracy, completeness or usefulness of any information, apparatus, product or process disclosed, or represents that its use would not infringe privately owned rights.

Abstract

An approach to fusion power is described which proposes magnetically driving a thin metal shell at high velocity ($\sim 10^4$ m/s) onto a warm (200-500 eV), dense (10^{24} - 10^{25} m $^{-3}$) plasma. A description of the plasma/liner interaction by several analytic and numerical models is given. On the basis of theoretical scaling predictions, the advantages, disadvantages and uncertainties associated with a high-efficiency (recirculating power fraction $\lesssim 0.2$) Fast-Liner Reactor (FLR) are described, quantified when possible, and summarized. The FLR approach is characterized by i) a thin cylindrical nonrotating liner that would be magnetically accelerated by axial currents driven through the liner (no external coils or magnets), ii) axial and radial energy confinement would be provided by an azimuthal magnetic field associated either with axial currents driven through a hard core or through the plasma, iii) the plasma particle pressure would be supported directly by the liner surface and material end plugs, and iv) the liner and a portion of associated support structure would be destroyed at each implosion. A preliminary assessment of the technological implications of blast confinement, materials destruction and loss, energy transfer and storage requirements, and possible modes of FLR operation is presented.

1. INTRODUCTION

The use of magnetically-driven metallic liners for the adiabatic compression of D-T plasmas to thermonuclear conditions has been proposed and analytically studied by a number of investigators (1-4). The largest imploding-liner programs to date have been at the Kurchatov Institute in the USSR (2) and at the Naval Research Laboratory (NRL) in the United States (3). The approach taken by the Kurchatov group has emphasized very fast ($\geq 10^3$ - 10^4 m/s radial velocity) implosions of thin metal shells in a variety of configurations, whereas the NRL group has been concerned primarily with slower ($\sim 10^2$ m/s) implosions of more massive, thicker liners in cylindrical geometry. The Los Alamos Scientific Laboratory has recently proposed (5) the use of fast ($\geq 10^4$ m/s) imploding liners that are driven magnetically by the self-fields associated with large axial currents driven through a cylindrical liner shell; this approach is similar to that followed ten years ago by Alikhanov, et al (6). Consideration of liner buckling and Rayleigh-Taylor stability, particle and energy confinement, and the

desire for very compact systems exhibiting high power densities has led to the choice of the fast mode. Fast implosions with an azimuthal drive field should alleviate the Rayleigh-Taylor instability, and completely stabilize the plastic-elastic buckling instability (8), allow wall-confinement of the plasma pressure, and result in high power densities. The technological problems associated with large energy (>1 GJ) releases over very short ($\sim 1 \mu\text{s}$) time intervals, however, are severe. The intent of this paper is to quantify the magnitude of these problems within the context of a power reactor and, where possible, to present plausible solutions. To a great extent the magnitude of these problems is related directly to the non-ideal behavior of a fast-liner/plasma system (i.e. liner compressibility, liner stability, field diffusion, thermal conduction, and radiation) as reflected by a realistic energy balance. The energy balance is examined in the context of such problems, and key technological issues associated with a Fast-Liner Reactor (FLR) are discussed.

2. THE FAST LINER CONCEPT

The essential elements of the Fast-Liner Reactor are depicted in Fig. 1. This concept proposes the magnetic implosion of a thin heavy metal liner of initial radius $r_{10} \approx 0.2-0.3 \text{ m}$, initial thickness $r_{20} - r_{10} \approx 1-10 \text{ mm}$, and length $l \approx r_{10}$ to a radial velocity of $\geq 10^4 \text{ m/s}$ with a plasma of initial temperature $T_0 \approx 100-500 \text{ eV}$ and initial density $n_0 \approx 10^{24}-10^{25} \text{ m}^{-3}$. This pre-implosion plasma would contain an embedded azimuthal magnetic field $B_{\theta}^{\text{INT}} \approx 5-10 \text{ T}$ ($I^{\text{INT}} \approx 5-10 \text{ MA}$) to reduce both axial and radial thermal conduction. The high-beta plasma ($\beta \gg 1$) would, therefore, be magnetically insulated, wall confined, and have a negligible magnetic pressure. The liner would carry its own implosion current I^{EXT} , and the implosion time of $\sim 10-20 \mu\text{s}$ in the presence of enhanced metallic viscous damping at very high pressures might obviate the necessity for the energetically costly and technologically difficult rotation against Rayleigh-Taylor hydrodynamic instabilities (7) at the inner surface of the liner. An ablated metallic vapor could still be troublesome in this respect. On the basis of preliminary calculations (8) the plastic-elastic or buckling instability should also be completely suppressed by the B_{θ}^{EXT} drive field. The B_{θ}^{INT} configuration shown in Fig. 1 has the advantage of inhibiting both radial and axial transport, whereas the use of an axial implosion current with the increasing inductance of an inwardly imploding liner leads to excellent coupling between the liner and the associated energy store.

Operation of the FLR sages the complete destruction of the liner and a portion of the associated lead structure. The reactor energy balance requires no reversible recovery of the original energy switched to the liner. The replacement cost of destroyed apparatus, the preparation and transport of the warm, dense feed plasma, the repetitive and non-destructive containment of the blast-like energy release, the method by which implosions can be made to occur at a frequency of $\sim 0.1 \text{ Hz}$, and the energy transfer and storage (ETS) system represent major areas of investigation for the reactor systems/design study. The difficulty of any one of these potential technological problems is

crucially dependent on the overall energy balance and intrinsic loss processes, both of which ultimately determine the magnitude of the total energy delivered to and released by each implosion.

3. ENERGY BALANCE MODEL

The physics model and preliminary engineering design for the FLR have been given in Ref. 5. The trade-off between the engineering Q-value $Q_E = 1/\epsilon$, where ϵ is the recirculating power fraction, and the blast-containment problem was examined in Ref. 9. The simplified but comprehensive energy balance is shown in Fig. 2, depicting two energy reservoirs which are depleted each power cycle: the plasma injection W_{INJ} and the liner power supply W_{LPS} , where all energy quantities are expressed per unit length of liner. The plasma injection energy supplies the initial plasma energy W_{PO} with an efficiency η_{INJ} , the energy $(1-\eta_{INJ})W_{INJ}$ being deposited to the thermal cycle as resistive heating and annihilated magnetic flux (i.e. W_{INJ} includes the bias field energy). Of the total energy W_{LPS} delivered from the liner power supply the fraction η_T is transferred to the liner as initial radial kinetic energy W_{KRO} , whereas $(1-\eta_T)W_{LPS}$ is dissipated to the thermal cycle as joule heating. Of the initial liner energy W_{KRO} the fraction η_C is used to compress the liner itself, and the energy $(1-\eta_C)W_{KRO} \equiv W_{PV}$ ideally compresses the plasma and bias flux. Depending upon the plasma conditions which evolve during an implosion, the actual compression work delivered to the plasma, $W_{PV} = W_{PV}^0(1-f_{RAD}-f_{COND})$, is reduced by the radiation loss, $W_{RAD} = f_{RAD}W_{PV}^0$, and the (radial and axial) conduction loss, $W_{COND} = f_{COND}W_{PV}^0$. If $Q \equiv W_N/W_{KRO}$ is the ratio of thermonuclear energy W_N (20 MeV/n) released in the form of neutrons divided by the initial liner energy, the alpha-particle energy release is $W_\alpha = (E_\alpha/E_N)QW_{KRO}$, where $E_\alpha = 3.5$ MeV and $E_N = 20$ MeV. The final plasma energy $W_{PF} = W_{PO} + W_{PV}$ and the liner compression energy $\eta_C W_{KRO}$ are assumed recovered through the thermal cycle, as are W_N , W_α , W_{RAD} , and W_{COND} . The energy $W_{PF} + W_\alpha + \eta_C W_{KRO} + (1/\eta_T - 1)W_{KRO} + W_{RAD} + W_{COND}$ is assumed to contribute to the post-burn blast, whereas the sonic shocks set up by the distributed neutron energy release W_N are considered to be less important (10). Expressions for $Q_E = 1/\epsilon$, the total thermal energy release W_{TH} , and the circulation energy W_C are depicted on Fig. 2. Given that $(\eta_T/\eta_{INJ}) \ll 1$, where $\xi = W_{PO}/W_{KRO}$, the following expression for Q_E results

$$Q_E = \eta_{TH} \left[1 + \eta_T Q \left(1 + E_\alpha/E_N \right) \right] \quad (1)$$

For example, if the desired recirculating power fraction $\epsilon = 1/Q_E$ is 0.20, $\eta_{TH} = 0.4$ and the transfer efficiency $\eta_T = 0.8$, then the required liner Q-value must be $Q = 12.2$. The relationship between intrinsic liner properties and Q now must be quantified.

4. FLR ENERGY SCALING

The complex task of relating thermonuclear yield W_N to the initial liner kinetic energy W_{KRO} by means of $Q = W_N/W_{KRO}$ has been approached on three levels. First, a purely analytic model (5,11,12), based on a more rigorous treatment of the impulse-momentum approximation than previously used (1), has been developed. Given that B_0 is the bulk modulus of the liner material at zero pressure and $B' = (dB/dP)$, and assuming a lossless plasma, the analytic relationship between the maximum Q and W_{KRO} is (12)

$$Q = 2.27(10)^{-6} \left[W_{KRO} \rho_\ell \right]^{1/2} \left[W_{KRO} / B_0 \pi (r_{20}^2 - r_{10}^2) \right]^{1/2(B'-1)}$$

$$= 4.02(10)^{-6} \rho_\ell v_{10} r_{10} \left[(r_{20} - r_{10}) / r_{10} \right]^{1/2} \left[\rho_\ell v_{10}^2 / 2B_0 \right]^{1/2(B'-1)}, \quad (2)$$

where ρ_ℓ is the liner density, v_{10} is the initial velocity of the inner surface of the liner, mks units are used, and the assumption has been made that the liner thickness $\Delta_0 = r_{20} - r_{10}$ at any time is such that the sound transit time through the liner is small compared to the implosion and dwell times. For example, Eqn. (2) predicts $W_{KRO} = 2.0(10)^9$ J/m for $\rho_\ell = 9400$ kg/m³ (Pb_{0.9}Li_{0.1}) and $Q \approx 15$, for $B' = 3.5$, $B_0 = 2(10)^{11}$ Pa (29.4 MPsi), $r_{10} = 0.2$ m and $r_{20} - r_{10} = 1.0$ mm.

The second level of the liner analysis is achieved by a computer model which treats the plasma as a single-fluid MHD gas in the radial direction and is based on a liner dynamics model that incorporates liner compressibility in a form found from the aforementioned impulse-momentum theorem. This model computes radial thermal conduction and field diffusion while incorporating an analytic approximation to axial thermal conduction as a function of radius. Computational models are also established for plasma radiation loss and alpha-particle deposition.

Figure 3 gives the dependence of Q on v_{10} for a range of loss processes and initial liner/plasma conditions, using a copper liner of density $\rho_\ell = 8900$ kg/m³ with $B_0 = 2 \times 10^{11}$ Pa and $B' = 3.5$. The electrical resistivity and thermal conductivity are those given by Braginskii (13), and the bremsstrahlung radiation per unit volume is taken as $P_{BR} = 5.475 \times 10^{-37} n^2 T^{1/2}$ in mks units except for T in keV. The alpha particle energy is assumed to be deposited in the liner. Curves 1-5 represent initial liner/plasma conditions of $W_{KRO} = 10$ GJ/m, $r_{10} = 0.3$ m, $n_0 = 5 \times 10^{24}$ m⁻³, $T_0 = 250$ eV and $B_{INT}^0 = 5$ T, where $B_0(r) = B_{INT}^0 r/r_{10}$ at the outset of the implosion. The initial liner thickness, Δ_0 , is proportional to $1/v_{10}^2$ to keep the liner kinetic energy fixed as v_{10} is changed. Curve 1 is for an incompressible liner and lossless plasma. The losses described above are subsequently "turned on" until all are in effect for Curve 5, including thermal conduction to the ends of a 0.1 m long liner. The set of curves with $W_{KRO} = 10$ GJ/m gave very poor performance with all losses in effect. In particular, the very dense plasmas used here produced excessive radiation loss,

particularly from the dense plasma immediately adjacent to the imploded liner.

Although scaling laws without losses indicate Q is proportional to $\sqrt{W_{KRO}}$ it was found that Q could be improved by reducing W_{KRO} and n_0 from the example above. Complex interactions between field, thermal diffusion and radiation reduce losses as W_{KRO} and n_0 are reduced. Curves 6-10 represent the case where $W_{KRO} = 1.7 \text{ GJ/m}$, $r_{10} = 0.2 \text{ m}$, $n_0 = 10^{24} \text{ m}^{-3}$, $T_0 = 500 \text{ eV}$ and $B_{INT} = 10 \text{ T}$. Here n_0 was reduced to diminish the effect of bremsstrahlung, W_{KRO} was reduced to lower the overall size of the system, and B_{INT} was increased to improve the resistance to cross-field thermal conduction in the plasma. This partial optimization was intended to improve Q values with losses in effect and $v_{10} \sim 10^4 \text{ m/s}$. Indeed, Curve 10 shows $Q = 14$ and 21 for $v_{10} = 10^4 \text{ m/s}$ and $1.8 \times 10^4 \text{ m/s}$ respectively. The discontinuities in Curves 8, 9 and 10 at $v_{10} \approx 3 \times 10^4 \text{ m/s}$ are related to the turn around point of the liner compression. On the high velocity side of these curves the inner edge of the liner turns around at $r_1 \sim 6 \text{ mm}$. When v_{10} is reduced to $\sim 2 \times 10^4 \text{ m/s}$, plasma losses reduce the temperature and pressure enough to prevent the liner from turning around at $r_1 \sim 6 \text{ mm}$. As the liner continues to move in, losses increase rapidly, reducing plasma pressure, and allowing the liner material per se to expand from its very compressed state at $r_1 \sim 6 \text{ mm}$. This mechanism appears to critically damp the liner motion and substantially increase the thermonuclear energy produced. Eventually radiation and thermal conduction cool the plasma below thermonuclear temperatures. In the model the liner turns around at $r_1 \ll 1 \text{ mm}$ when it impinges on a cold dense plasma. At such small radii and high densities the model certainly breaks down, but this is of little concern, since the energy release is attained before this point where the analysis breaks down.

Many physical effects must still be incorporated into this model, such as joule losses in the liner, alpha pressure, turbulence, etc. Some of these will undoubtedly come out of the third level analysis discussed below. Until then a reactor example is taken from Curve 10 of Fig. 3: $W_{KRO} = 1.7 \text{ GJ/m}$, $n_0 = 10^{24} \text{ m}^{-3}$, $T_0 = 500 \text{ eV}$, $B_{INT} = 10 \text{ T}$, $r_{10} = 0.2 \text{ m}$, $\ell = 0.2 \text{ m}$, $v_{10} = 1.22 \times 10^4 \text{ m/s}$ and $\Delta_0 = 2 \text{ mm}$, leading to $Q = 15$.

The third level of analysis considers a radial, two-fluid MHD treatment of both the plasma and detailed compressible liner dynamics (5,11), using tabulated equation-of-state data. This complex code system is used for numerical "research" of fundamental liner/plasma processes and also is used to test the validity and accuracy of both the analytic and hybrid MHD FLR models. Generally, FLR parameter studies are made with the hybrid analytical/numerical model described under level two. On the basis of data similar to those given on Fig. 3, FLR systems with $Q_E \approx 5$ will require $Q \approx 15-20$ and $W_{KRO} \approx 1-10(10)^9 \text{ J/m}$, accounting for all loss processes except field and thermal diffusion in the liner and neglecting alpha-particle/plasma interactions. Liner lengths and radii in the range 0.2-0.3 m are expected, with initial liner thicknesses $r_{20} - r_{10}$ of a few millimeters envisaged. The key technological implications of this magnitude of energy release are now summarized.

5. MAJOR TECHNOLOGICAL IMPLICATIONS

The $Q = 16$, $Q_E = 5$, $W_{KRO} = 1.7(10)^9$ J/m case is treated here as an example by which crucial technological implications are examined. The FLR power supply for $\eta_T = 0.8$ must deliver $W_{LPS} = 2.1(10)^9$ J/m, and the major part of the loss $(1 - \eta_T)W_{LPS}$ is assumed deposited as joule heating in and near the liner. Corresponding to the $W_N = W_{KRO}Q \approx 2.7(10)^{10}$ J/m fusion neutron energy, $4.75(10)^9$ J/m will be deposited in or near the liner by alpha particles and, therefore, should also contribute to the post-implosion blast. Neutronics analyses (5) of the fusion-neutron/liner interaction indicates that $\sim 1\%$ of W_N will also be deposited into the compressed liner for the initial liner thickness being considered. Hence, a total of $W = 7.1(10)^9$ J/m will appear in the vicinity of the liner within ~ 10 μ s after the implosion commences. The total energy contributing to the blast corresponds to $Wl = 1.4$ GJ for $l = 0.2$ m or 56 GJ/m³ based on the initial liner volume (3.7×10^{10} Pa or 0.37 MB pressure, if totally isotropized and thermalized). Needless to say, the magnitude and time scale of this energy release and energy density will have a strong influence on the design of a power-producing FLR.

5.1. Blast Confinement

The "virial theorem" (14) provides a convenient means to estimate the magnitude of the blast containment problem. One form of this theorem (15) predicts that the mass M of a vessel needed to contain a gas or plasma of energy Wl must be greater than $2Wl/f\sigma$, where ρ is the density of the containment, f is the number of stress components in the vessel wall ($f = 2$ for a sphere of radius R and wall thickness ΔR), and σ is a minimum allowable stress (e.g. the elastic limit). Taking $M = \rho 4\pi R^2 \Delta R$, $f = 2$ and $\sigma = E\varepsilon/(1-\nu)$, where E is Young's modulus (taken to be $1.9(10)^{11}$ Pa or 28 Mpsi), ν is Poisson's ratio (~ 0.3), and ε is the strain

$$(\Delta R/R)\varepsilon \geq (1-\nu) (Wl/R^3)/4\pi E \quad (3)$$

Equation (3) predicts surprisingly well a wide range of experimental data (9,16) obtained from explosives detonated in spherical vacuum vessels. For the blast conditions cited above $R^2\Delta R\varepsilon \geq 410$, where ε is measured as microstrain. For most steels the plastic limit occurs for $\varepsilon \sim 3000$. To account for cyclic fatigue ε is taken to be 2000, which results in $\Delta R = 0.03$ m if $R = 2.6$ m. Although reasonable in themselves, these dimensions can be significantly reduced (9,16) if a shock-mitigating medium replaces the vacuum assumed here. The potential for dimensional decreases, however, no doubt would be reduced when a more conservative engineering design is applied to this containment problem.

Given the thermonuclear energy that could potentially contribute to the blast is $W = W_{KRO} \left[1/\eta_T + (E_\alpha/E_N + 0.01)Q \right]$, whereas the total thermal

energy release is $W_{TH} = W_{KRO} \left[1/\tau_T + (E_p/E_N + 1)Q \right]$, the ratio W_{TH}/W for the example case considered here is 4.76. Hence, the average thermal power density P_{TH} (MWt/m³), averaged over the total containment volume, is given by

$$P_{TH} \tau_C \leq 3E/(1-\nu) (W_{TH}/W) (\Delta R/R) (10)^{-12} \quad (4)$$

where τ_C is the average time between pulses. For the parameters given above P_{TH} (MWt/m³) $\approx 89/\tau_C$; for cycle times on the order of 10 to 100 s the thermal power density is considerably higher than power densities anticipated for most magnetic confinement schemes. This potentially high average power density associated with a relatively small device represents a major advantage and presents a strong incentive for studying the fast liner approach to fusion.

5.2 Material Damage and Costs

Given an acceptable solution to the blast confinement problem, the economic implications of materials and fabrication costs represents a major hurdle for the FLR concept. For the sample case considered here, $W_{TH} = 34.1(10)^9$ J/m, which when converted at $\eta_{TH} = 0.4$ and $\epsilon = 1/Q_E = 0.2$ corresponds to 3030 kWeh/m of net electrical energy. At 10 mills/kWeh for steam-electric station generation costs, the total revenue per implosion amounts to 30.3 \$/m. Considering the destroyed liner (and leads) replacement cost as an effective fuel cost, this cost probably should not exceed 20%-30% of the total electric generation cost or 6-9 \$/m of the total revenue (\$1.20-\$1.80 for $l = 0.2$ m).

Although a comprehensive study of this complex problem has not been made, a preliminary estimate of the materials cost vs energy revenue relationship can be made. For the liners considered here, ~ 15 kg/m of insulator (pyrex) and ~ 22 kg/m of liner metal (near Cu density) will be required. If only the liner were destroyed, then the allowable materials recovery and refabrication cost would amount to 0.16-0.24 \$/kg averaged between the insulator and metal.* For most liner metals considered, recovery and fabrication would be advisable and in some cases necessary. The use of liner insulation of the kind presently used to bottle beverages (a typical soft-drink bottle machine produces ~ 12000 units/h (17)) would be sufficiently economical to preclude recovery and refabrication. The major uncertainty, therefore, does not appear to be the costs of liner fabrication and replacement, but rather the degree to which other apparatus is destroyed (e.g. liner support structure, electrical leads, feedthroughs, etc.). The FLR design has not progressed to a point where this potentially serious problem can be resolved.

*A few representative material costs in \$/kg are: commercial lead ingot (0.57), cold-rolled steel (0.31), copper plate (2.31), large-bore pyrex tubing (2.86), soft-drink bottle glass (0.02), alumina powder (2.20).

5.3 Energy Transfer and Storage (ETS) Requirements

For a transfer efficiency $\eta_T = 0.8$, the total stored/switched energy amounts to $W_{LPS} = 2.13(10)^9$ J/m or 0.425 GJ for $l = 0.2$ m. No reversible recovery of this energy is necessary or planned. Preliminary calculations (5) have considered both pure capacitive ETS and homopolar motor/generator ETS systems. In the latter case the homopolar unit would discharge slowly as a capacitor into a storage inductor, which in turn would be rapidly switched into the time-varying liner inductance. Transfer efficiencies for both ETS systems were found to be $\sim 70\%$. In general, the fast-pulse, high repetition-rate transfer of GJ levels of energy, particularly with respect to fast (high-voltage) switching, presents an unresolved and potentially difficult technological problem.

5.4. General Aspects of FLR Operation

The FLR design effort has largely focused on resolving the behavior of the liner/plasma system, developing analytic and numerical scaling relationships, and assessing qualitatively a few of the aforementioned uncertainties and problems; the reactor embodiment of the FLR concept is still evolving.

On the basis of scoping calculations described in Sec. 5.1 and Ref. 9, three FLR confinement schemes have evolved and are depicted in Fig. 4. First, the liquid-metal ($Pb_{0.9}Li_{0.1}$)/gas-bubble (He) concept was developed, wherein a liner assembly suspended from an electrical-lead and support "stalk" would be plunged into the two-phase coolant and detonated, in much the same way proposed for certain laser/pellet fusion schemes (9,18). Unacceptably high pressure amplification at the container wall by shock reflection (9), even for very high He-bubble fractions, led to the rejection of this concept. The favorable scaling of containment vessel size with blast energy, as predicted by the virial theorem (9) (Sec. 5.1), and the agreement that this theory gave with experimental data led to the consideration of implosions detonated in vacuo, the vacuum chamber being surrounded by a neutron-attenuating, tritium-breeding blanket. Although this concept is still under study, the potential problem of rapid insertion of liner assemblies into a vacuum, the use of high-voltage in vacuums, and the potential of serious damage to the vacuum wall by radiation and massive, energetic debris has resulted in more serious consideration being given to the third concept depicted on Fig. 4.

For this third concept the liner assembly (including a massive return conductor) is suspended in a fluidized bed of lithium-bearing particles (oxide, aluminates, etc.). The fluidized particle bed would operate at 30%-50% of solid density, the bed would be thick enough to absorb all neutrons, the particles would be pulverized under the action of the post-implosion shock, would breed tritium, and with the (He) carrier gas would serve as the primary heat-exchange fluid. After the

fluidized bed "recovers" from a given detonation. The fine, pulverized particles (and thermal energy) would be removed from the system by the carrier gas, cooled, cyclone separated from the carrier gas, re-sintered, and cycled back to the fluidized bed. The pulverizing action of the post-implosion shock would also release bred tritium from the bed particles, and the released tritium could easily be recovered from the He carrier gas by oxidation. Large sintered particles generated within the fluidized bed (typically at the container walls) as well as large pieces of liner debris attenuated by the fluidized particles, would fall out and be collected for reprocessing. Because of the inherent simplicity and multiple utility of the fluidized-bed concept, serious design effort is being devoted to this particular version of the FLR.

6. SUMMARY

The principle advantages, disadvantages, and uncertainties associated with the fast-liner approach to fusion power have been outlined. From the viewpoint of the reactor designer, the distance from the mainstream, the unknown and uncertain physics, and the absence of relevant experimental experience represent serious limitations; the scaling upon which the FLR design must proceed has little basis in experiment or contemporary technological experience. The advantages of the fast-liner concept, generally, are overwhelming: very high power densities in a fraction of a liter of wall-confined plasma (at full compression) reacting to yield net power on a time scale that is short compared to classical processes which drive energy loss. With respect to this last point, the plasma is always at the "first-wall," and the major concern, therefore, is not the gross MHD stability of a tenuous plasma column, but rather the generation of local turbulence (e.g. local vortices driven by steep temperature gradients) which may enhance cross-field heat transport. The physics and technological problems/uncertainties associated with this approach are equally impressive: implosion velocities in excess of 10^4 m/s; fast (high-voltage) switching of GJ levels of energy (non-reversibly, however) into a pre-implosion volume of ~ 25 liters; rapid, destructive releases of energy equivalent to nearly 1 Tonne of TNT repetitively contained ($\sim 10^6$ times a year); the preparation and timely injection of 200-500 eV plasma into the liner at densities in the range 10^{24} - 10^{25} m $^{-3}$; high density, inexpensive, high conductivity liner materials; and a potentially serious materials management and cost constraint. The aforementioned potential which fast-liner fusion promises, however, coupled with a real possibility of rapid exploitation of small scale D-T fusion power systems, if the physics proves as "reasonable" as calculational models indicate, certainly warrants more serious experimental and computational consideration of this approach.

7. REFERENCES

1. SHEARER, J.W., W.C. CONNIT, "Magnetically Driven Liners for Plasma Compression," Energy Storage, Compression and Switching (1976), p. 105, Plenum Publishing Corporation, NY (1977).

2. ALIKHANOV, S.G., et al., "Studies of Models of Thermonuclear Systems," Proc. 6th International Conf. on Plasma Physics and Controlled Nuclear Fusion, IAEA-CN-35/I4, Berchtesgaden, FRG (October, 1976).
3. BOOK, D.L., et al., "Stabilized Imploding Liner Fusion Systems," *ibid.*
4. RIOUX, C., C. JABLON, "Losses of a Thermonuclear Plasma Imploded by a High-Velocity Wall," Nucl. Fus., 15, 425 (1975).
5. SHERWOOD, A.R., et al., "Fast Liner Proposal," USERDA Rept. LA-6707-P, (August, 1977).
6. ALIKHANOV, S.G., et al., "J. Scientific Instruments" (J. Phys. E.) Series 2, 1, 543 (1968).
7. BARCLON, A., D.L. BOOK, A.L. COOPER, "Hydrodynamic Stability of a Rotating Liner," Phys. Fluids, 17, 9, 1707 (1974).
8. SUYDAM, B.R., "Another Look at the Buckling Instability," personal communication, LASL (1977).
9. KRAKOWSKI, R.A., R.W. MOSES, "Energy-Balance and Blast Containment Consideration for FLR," USERDA Rept. LA-UR-77-1276 (1977).
10. DRESNER, L., "Mechanical Stress in the Pressure Vessel of a Lithium-Filled, Exploding Pellet, Thermonuclear Reactor," USAEC Rept. ORNL-TM-4050 (1973).
11. GERWIN, R., R. MALONE, J. MARSHALL, T. JARBOE, A. SHERWOOD, G. SAWYER, "Proposal for Accelerated Fast Liner Program," USERDA Rept. LA-UR-77-2227 (1977).
12. GERWIN, R., R. MALONE, "Theory of Plasma Heating by Fast Liner Implosion," submitted to Nucl. Fusion (1977).
13. BRAGINSKII, S.I., "Transport Phenomena in a Completely Ionized Two-Temperature Plasma," Soviet Physics JETP, 6 (33), 358-369 (February, 1958).
14. LONGMIRE, C.L., Elementary Plasma Physics, Interscience Publishers, NY (1963).
15. MOSES, R.W., "Flywheel Energy Storage," Physics Today, 15 (October, 1975).
16. NEAL, T.R., R.H. BARNES, personal communication, LASL (1977).
17. BLEWETT, R., Glenshaw Glass Co., Glenshaw, PA, personal communication (1977).
18. FRAAS, A.P., "The BLASCON - An Exploding Pellet Reactor," USAEC Rept. ORNL-TM-3231 (July, 1971).

8. FIGURE CAPTIONS

- Fig. 1. Schematic diagram of essential elements of a Fast-Liner Reactor (FLR).
- Fig. 2. Schematic diagram of FLR energy balance (refer to text for notation).
- Fig. 3. Effects of various loss processes on FLR Q -value using single-fluid MHD model and analytical approximation for liner compression.
- Fig. 4. Schematic diagram of three potential confinement schemes considered for FLR.

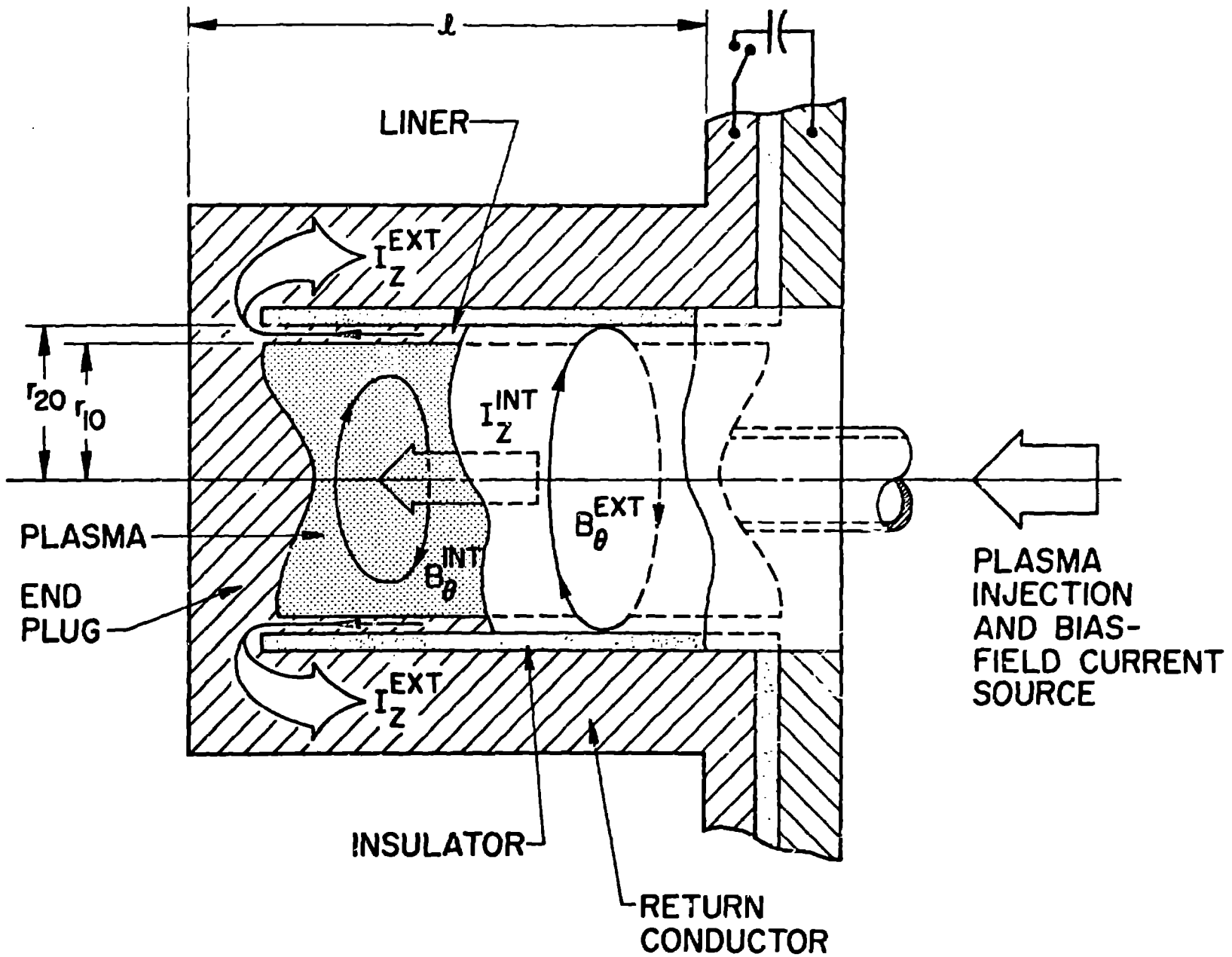
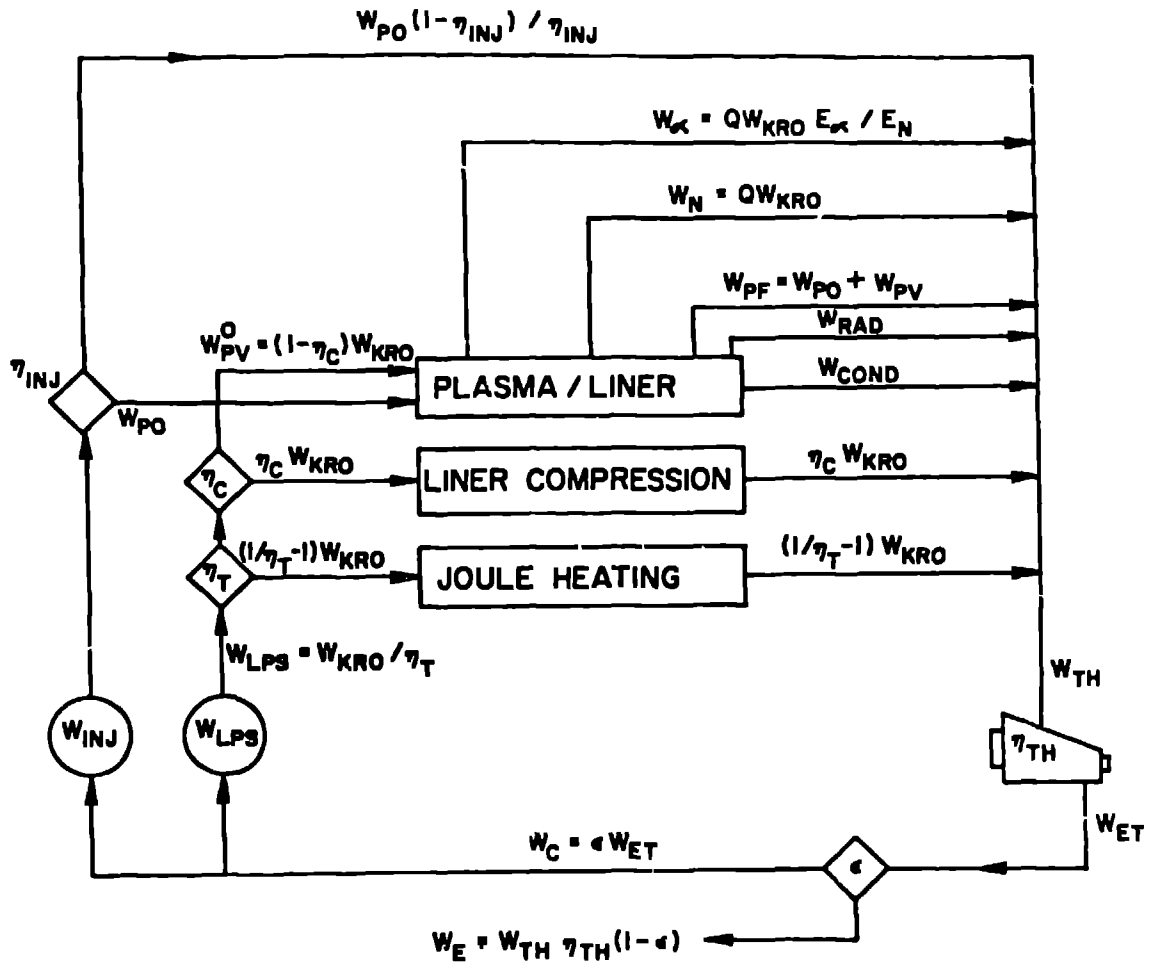

Fig. 1. Schematic diagram of essential elements of a Fast-Liner Reactor (FLR).



$$W_C = W_{KRO} (1/\eta_T + \epsilon/\eta_{INJ}), \quad \epsilon = W_{PO}/W_{KRO}$$

$$W_{TH} = W_{KRO} [Q(1 + E_a/E_N) + 1/\eta_T + \epsilon/\eta_{INJ}]$$

$$Q_E = 1/\epsilon = \eta_{TH} \frac{Q\eta_T(1 + E_a/E_N) + 1 + \epsilon(\eta_T/\eta_{INJ})}{1 + \epsilon(\eta_T/\eta_{INJ})}$$

Fig. 2. Schematic diagram of FLR energy balance (refer to text for notation).

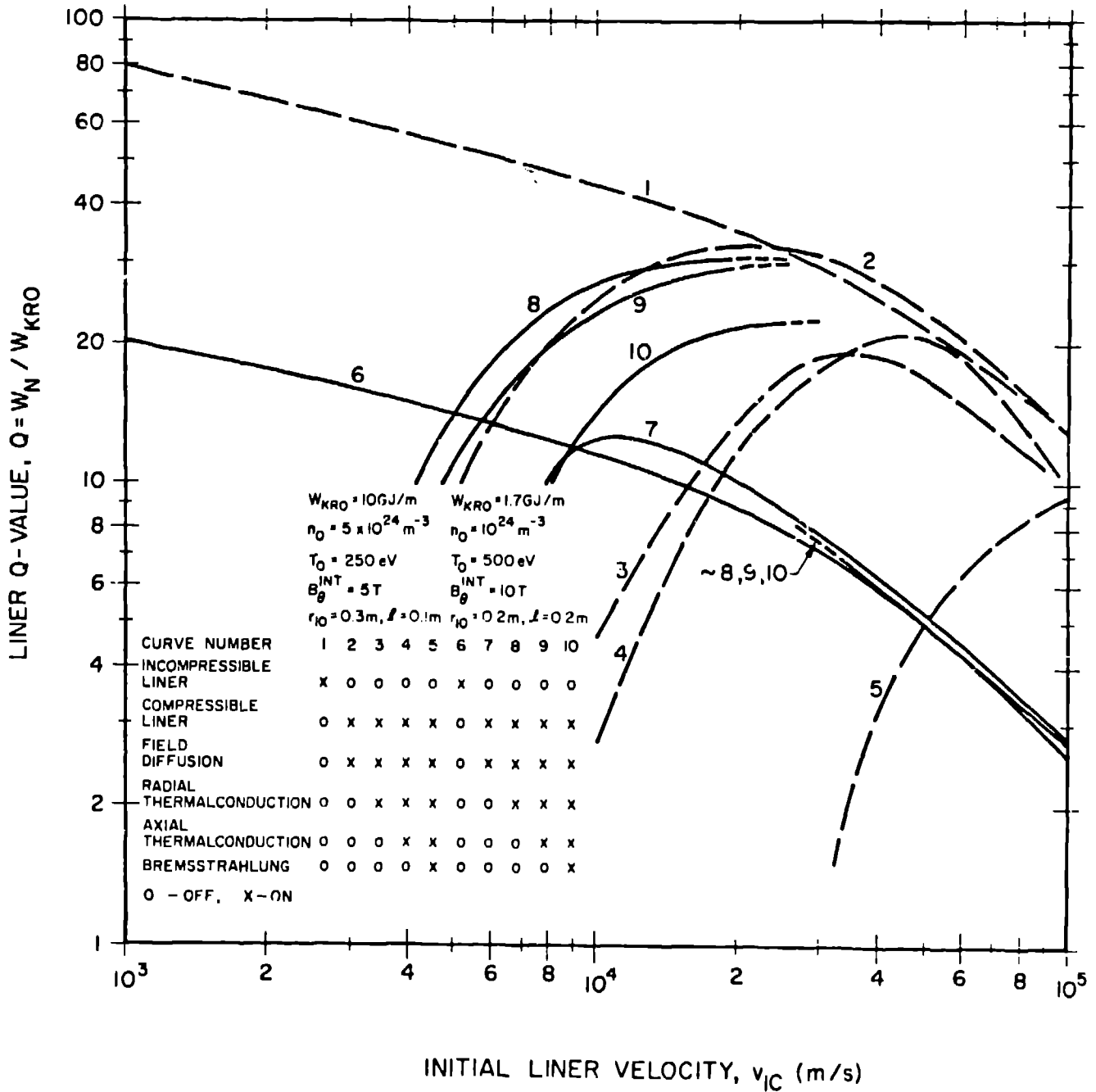

Fig. 3. Effects of various loss processes on FLR Q-value using single-fluid MHD model and analytical approximation for liner compression.

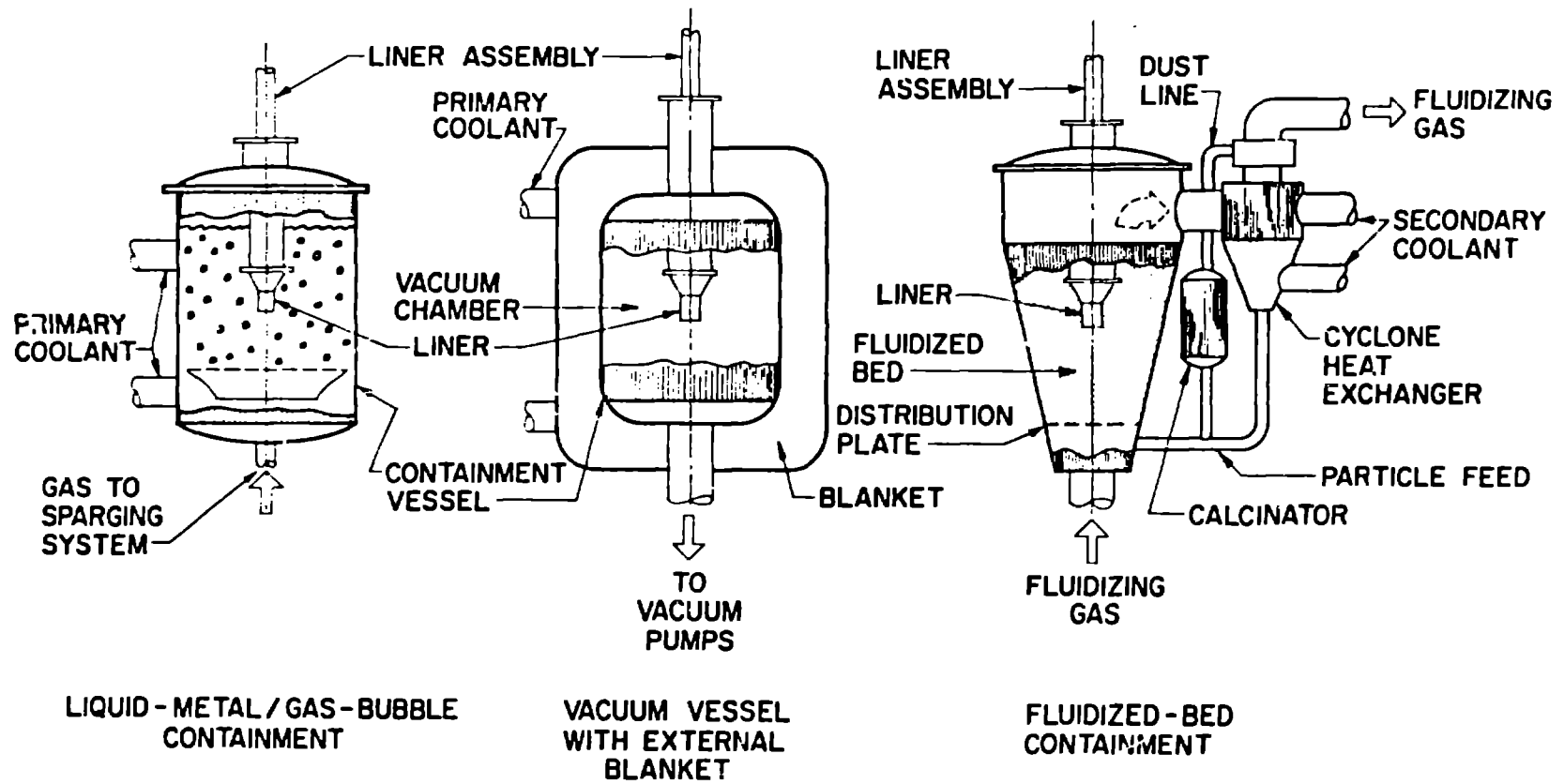

Fig. 4. Schematic diagram of three potential confinement schemes considered for FLR.