

Received by OSTI

AUG 05 1986

Los Alamos National Laboratory is operated by the University of California for the United States Department of Energy under contract W-7405-ENG-36

TITLE: EXPERIMENTS WITH MULTI-MEGAMPERE EXPLOSIVELY FORMED
FUSES IN CYLINDRICAL GEOMETRY

LA-UR--86-2378

DE86 013848

AUTHOR(S): J. H. GOFORTH
S. P. MARSH
I. LINDEMUTH
H. W. KRUSE

SUBMITTED TO: Fourth International Conference on Megagauss Magnetic Field
Generation and Related Topics, 14-17 July 1986, Hilton Inn,
Santa Fe, NM, USA

DISCLAIMER

This report was prepared as an account of work sponsored by an agency of the United States Government. Neither the United States Government nor any agency thereof, nor any of their employees, makes any warranty, express or implied, or assumes any legal liability or responsibility for the accuracy, completeness, or usefulness of any information, apparatus, product, or process disclosed, or represents that its use would not infringe privately owned rights. Reference herein to any specific commercial product, process, or service by trade name, trademark, manufacturer, or otherwise does not necessarily constitute or imply its endorsement, recommendation, or favoring by the United States Government or any agency thereof. The views and opinions of authors expressed herein do not necessarily state or reflect those of the United States Government or any agency thereof.

By acceptance of this article, the publisher recognizes that the U.S. Government retains a nonexclusive, royalty-free license to publish or reproduce the published form of this contribution or to allow others to do so, for U.S. Government purposes.

The Los Alamos National Laboratory requests that the publisher identify this article as work performed under the auspices of the U.S. Department of Energy.

 **Los Alamos** Los Alamos National Laboratory
Los Alamos, New Mexico 87545

MASTER

gaw

EXPERIMENTS WITH MULTI-MEGAMPERE EXPLOSIVELY FORMED

FUSES IN CYLINDRICAL GEOMETRY*

J. H. Goforth, S. P. Marsh, I. Lindemuth, and H. W. Kruse

Los Alamos National Laboratory
Los Alamos, NM, 87545, USA

INTRODUCTION

Taking advantage of the high energy density attainable in the magnetic field of an inductor requires a prime power source capable of producing very large currents and a means of extracting the energy as a fast current pulse from the inductive store. Many existing high current sources have pulse risetimes of hundreds of microseconds, while most pulsed power applications have submicrosecond pulse requirements. In principle, high current opening switches represent a good solution to the problem. An inductor is charged over a long period of time by a relatively slow current supply with a closed switch completing the circuit. At a desired time, the switch is opened and the voltage produced transfers current rapidly to a load circuit. In practice, building opening switches that will carry multimegampere currents for hundreds of microseconds and then open on a submicrosecond time scale has posed an extremely difficult problem.

Explosive-driven opening switches have been used in long-pulse applications for some time,¹ but until recently the explosives systems used to drive these devices would not produce a rapidly opening switch. We have developed a fast technique for interrupting large currents² by using explosives to extrude short sections of relatively thick conductors into long thin fuse-like conductors. Although the formation of the fuse requires about 2 μ s, the switch will sustain considerable voltage as its resistance rises, and it is feasible to deliver pulses with ~ 1 μ s risetimes to low inductance loads. We discuss here the small scale proof of principle experiments and 2-D hydrodynamics calculations that have led to an optimized cylindrical opening switch design. In addition, we will describe the results of testing a cylindrical switch at currents up to 4.6 MA, and give extrapolations for device designs for the 15-20 megampere range.

* Supported by the US Department of Energy.

EXPLOSIVELY FORMED FUSES

The work that led to the Explosively Formed Fuse concept was begun as an attempt to utilize linear high pressure Mach interactions occurring at junctions of linear detonation fronts to sever a conducting plate. The plate was supported on a stepped dielectric material with voids behind the Mach interaction zones, and was simultaneously severed along several lines perpendicular to current flow. The technique yielded an opening switch behavior, and to ascertain the benefit gained by using the Mach interactions, we conducted a test in which the explosive in contact with the plate was detonated over its entire surface simultaneously rather than along discrete lines. The result was the best opening switch experimental result we had ever experienced, and we subjected the technique to further tests using different materials² with equally good results. To gain insight into the technique, we ran a series of two-dimensional hydrodynamic code calculations to compare with our experiments. By comparing these calculations to experimental results we learned that the conducting plate is never severed during the current interruption process. Instead, the conductor is extruded into thin ribbons that vaporize due to the action of the high currents. Thus, the technique that we initially dubbed Simultaneous Explosive-Driven Breaker was renamed Explosively Formed Fuse.

TWO-DIMENSIONAL CODE CALCULATIONS AND SMALL SCALE TESTS

Our computational studies of Explosively Formed Fuses have been performed with a two-dimensional Eulerian hydrodynamics code. It is multi-material and can handle high explosive using a programmed (or time-assigned) burn. Although the calculations include no electro-magnetic effects, we have gained much insight into the mechanisms involved by computationally examining the hydrodynamics and comparing these calculations to the experimentally obtained electrical behavior. By iterating many times between calculation and experiment, we have developed confidence in our ability to use the code to design Explosively Formed Fuses. The results of a typical calculation are given in Fig. 1. The system consists of an aluminum conductor on a stepped Teflon forming die consisting of anvils in contact with the aluminum and voids into which the aluminum is driven by the explosive. The figure shows the evolution of the fuse from its initial condition through the time when we have experimentally observed fusing to occur. This particular calculation was for a switch optimized for high energy dissipation per unit length. Several features of the calculation are noteworthy. First, the code predicts that the aluminum does not sever even though this is well within the code's capability. Second, the length of the fuse formed depends on the hydrodynamic flow that develops as the aluminum is driven into the die. In addition, the depth of the void is important to the extent that the most rapid extrusion occurs while the expansion is not impeded. Finally, two regions where voltage standoff may be a concern are shown. The first region is the width of the anvil, especially late in time when jetting Teflon from the bottom of the void may thin the anvils at their bases. Teflon is chosen for the die because of its properties as a dielectric at high shock strengths. However, if the switch must survive large voltage spikes late in time when the anvils have thinned, enough bulk dielectric must still remain. The second region of concern is the gap between adjacent anvils. The flow pattern pushes the conductors from adjacent anvils together, and there is a considerable voltage drop across this gap. The gap must be wide enough for the explosive products filling it to withstand the imposed voltage.

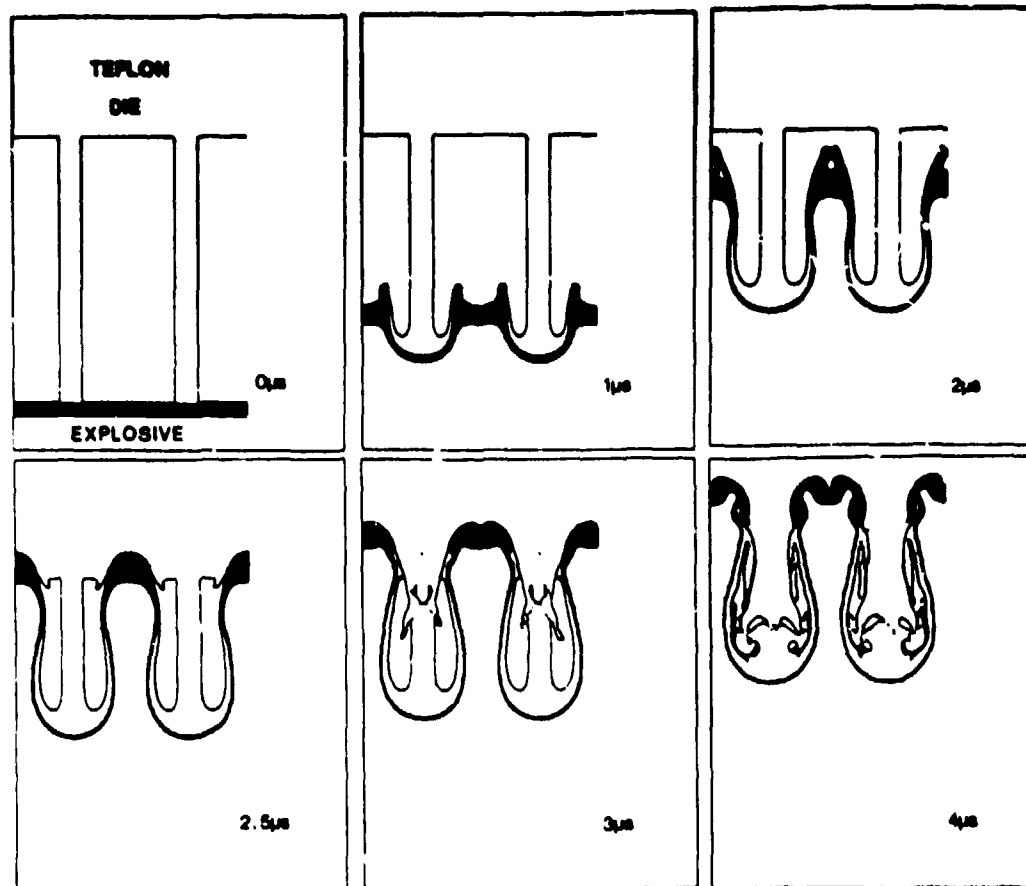

Fig. 1. Evolution of an Explosively Formed Fuse. At time = 0 (upper left) the cross-hatched aluminum conductor has just begun to be driven into the Teflon die. The calculation considers a die with one complete anvil-void-anvil pattern, and one half of a void on each side. The problem is bounded to right and left by reflective boundaries. In this calculation the voids are 6.5-mm-wide and 13-mm-deep. The Teflon anvils are 1.5 mm wide. At $t = 3 \mu\text{s}$, jets from the void bottom are seen to impact the anvils and although this is a concern, no failure of the switch has been found experimentally. Another design consideration is the narrow gap between adjacent anvils, seen at $t = 4 \mu\text{s}$, that could lead to high voltage breakdown.

Although the calculation shown in Fig. 1 was for a system optimized for energy dissipation, the good agreement we have obtained between experimental data and features observed in the calculations leads us to believe that we can use the calculations to optimize performance over a wide range of parameters to meet a variety of needs. To allow inexpensive iterations between calculations and experiments, we used the simple experimental setup shown in Fig. 2. Five voids were cut in the Teflon die material with void and anvil dimensions chosen to compare with code calculations. In the experiments described here we have used 0.08-cm-thick, 6.4-cm-wide aluminum, for our conductor, and our explosive system has always been a 2.5-cm-thick, 10-cm-diameter disk of PBX-9501 explosive initiated with a plane wave lens. Stock grade brass plates were used for transmission lines to adapt the parallel plate test geometry to Belden YK-198 cables attached to a capacitor bank. A 1500 μF capacitor bank was used at voltages up to 10 kV for all these tests, and the total system inductance was typically $\sim 200 \text{ nH}$. No load was switched into the circuit for voltage relief in these tests.

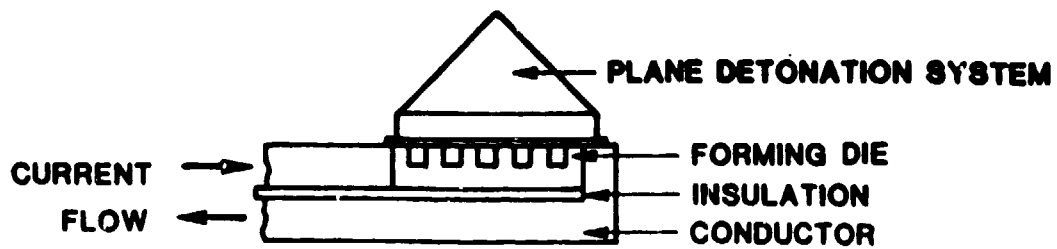

Fig. 2. Small scale parallel plate test setup. An aluminum conductor is driven into the die by a plane wave detonation system.

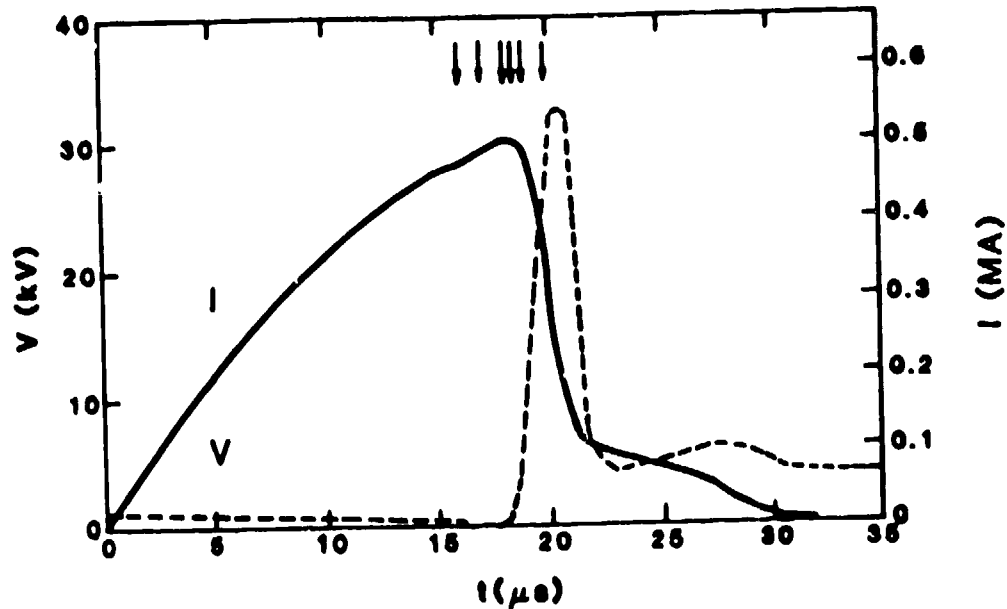

Fig. 3. Current and voltage waveforms from a small scale test corresponding to calculation in Fig. 1. Arrows indicate the times of the frames in Fig. 1.

Figure 3 shows current (I), and voltage records for an experiment corresponding to the calculation in Fig. 1. Times of the corresponding frames of Fig. 1 are indicated by the arrows. This test was purposely performed with more electrical energy in the circuit than the switch could dissipate in order to determine the limits of the design, and the break in the current waveform at $\sim 21 \mu\text{s}$ indicates the limit of $\sim 24 \text{ kJ}$ has been reached. Many other die configurations were tested using this basic setup and while this test demonstrated the largest energy dissipation per unit length across five voids, different configurations performed better in other respects. Since our present application requires dissipating a large amount of energy, however, the primary die geometry chosen for testing in a cylindrical switch is that shown in Fig. 1.

CYLINDRICAL EXPLOSIVELY FORMED FUSE

The parallel plate geometry used in the small scale tests described above is convenient and inexpensive, but not practical for multimegampere experiments. A cylindrical Explosively Formed Fuse design for use at higher currents is shown in Fig. 4. Current is input to the device through cables that couple the switch to an explosive plate generator. In addition, the cables serve a second function.

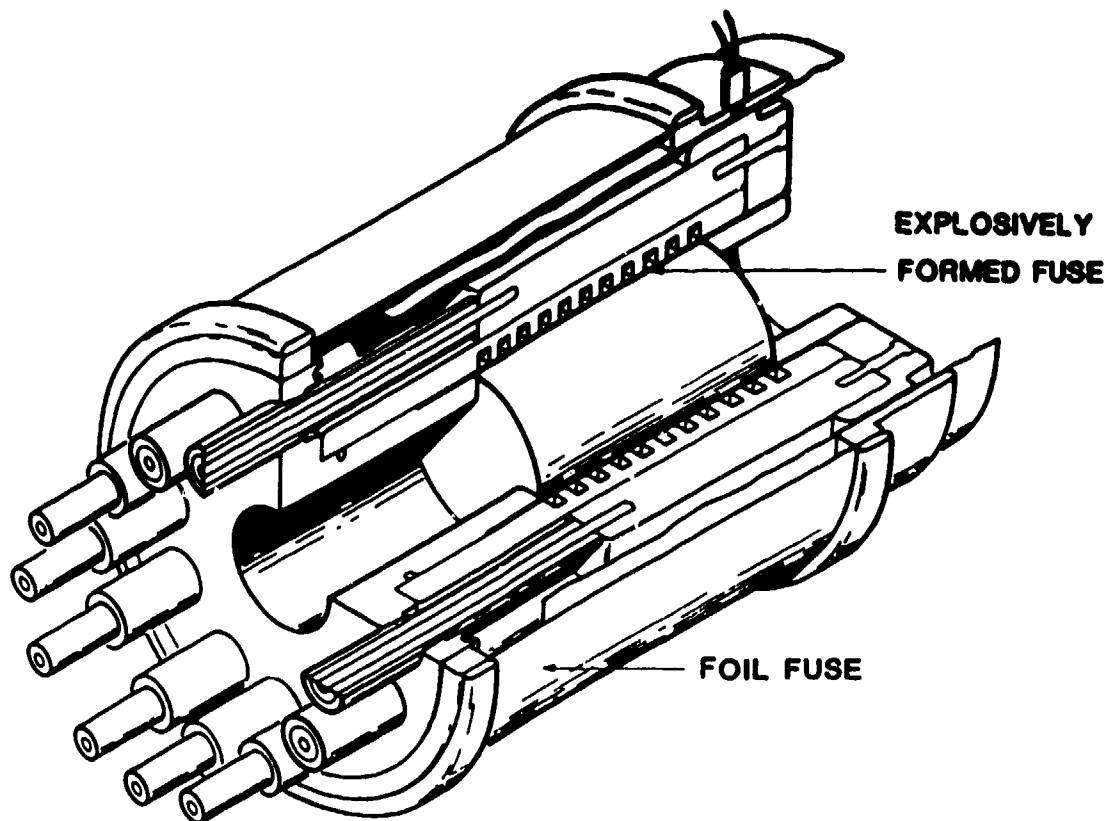

Fig. 4. Cylindrical Explosively Formed Fuse with conventional fuse load. The opening switch is actuated by detonating the cylindrical explosive charge, and detonator-driven closing switches introduce current to the Foil Fuse. The Explosively Formed Fuse is 9.2 cm in diameter, and 15.2-cm-long.

The switch itself is a triaxial arrangement with the center conductor common to both the conduction phase of the Explosively Formed Fuse and the subsequent current pulse to the load. The cables, which have been tested with pulsed voltages exceeding 500 kV, are a convenient low inductance means of coupling any device to this triaxial arrangement. In this geometry, the Explosively Formed Fuse is actuated by detonating a cylindrical explosive charge simultaneously on axis and driving the aluminum tube outward into the die. As the switch opens, detonator actuated closing switches divert current to the load. The load shown here is a conventional exploding foil fuse that we have incorporated in the tests for two reasons. For faster applications than can be powered by the Explosively Formed Fuse directly, fuses can be used as a second stage opening switch for further pulse compression. In addition, the switch must be tested for its hold-off capabilities when it is subjected to voltage spikes from dynamic loads and the fuse loads serve this purpose as well.

We have conducted a series of tests using the cylindrical switch pictured in Fig. 4, and have learned a great deal. Two different die patterns have been used with both static and dynamic loads, and we have extended the conduction time of the device to 90 μ s without observing operational difficulties. The data in Figs. 5 and 6 are from one experiment that illustrates much of what we have learned. Figure 5 shows the entire current pulse in the inductive store and the current pulse delivered to the fuse. In this experiment, the inductive store was the dynamic inductance of a plate generator which serves to amplify the current in the circuit as well as provide an inductive store.

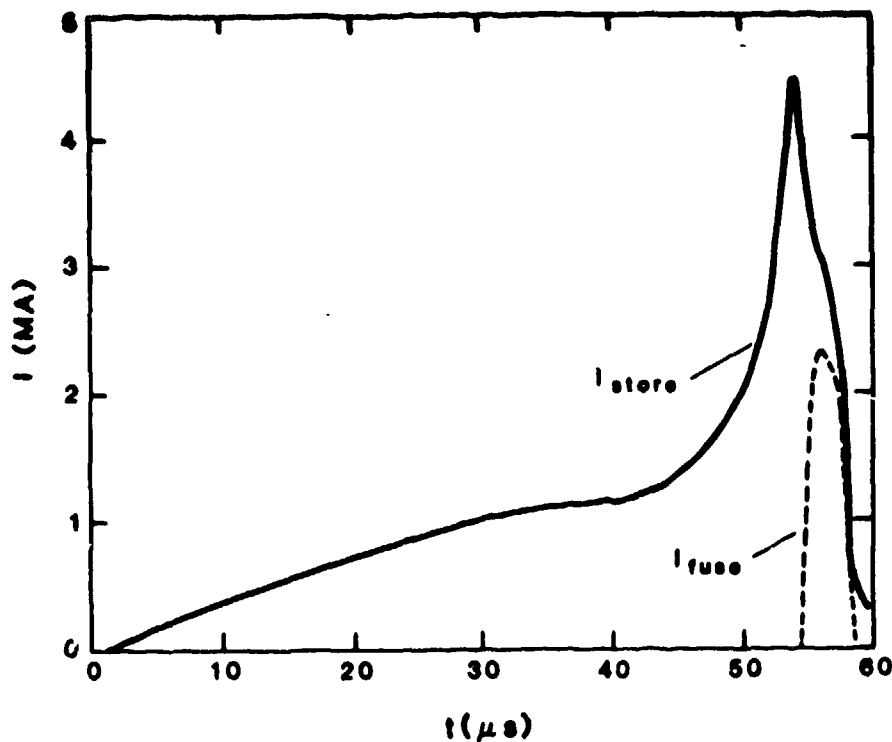

Fig. 5. Current pulses in the inductive store and fuse load in a cylindrical Explosively Formed Fuse test.

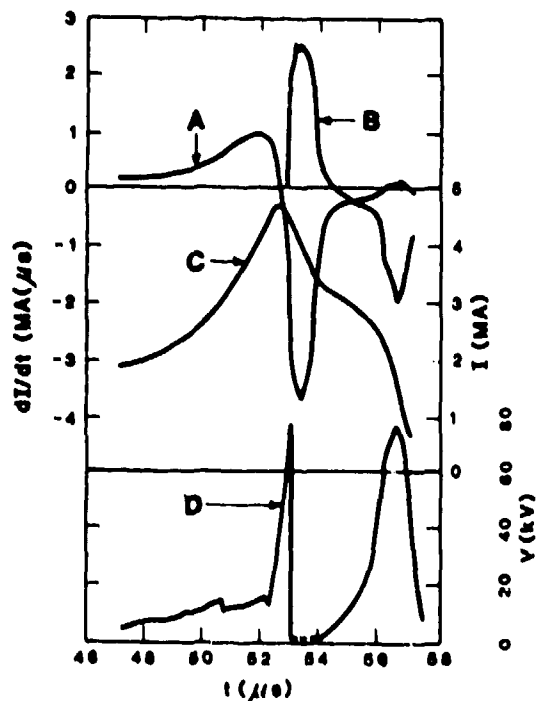

Fig. 6. Curve A is dI/dt measured in the Explosively Formed Fuse. Curve B is dI/dt measured in the Fuse load. Curve C is I_{store} . Curve D is Voltage waveform showing Explosively Formed Fuse voltage before closing switch actuates at 53 μs and foil fuse voltage afterward. The dotted section of curve D was too noisy to interpret. The time scale is common to Fig. 5.

Figure 6 shows I in the inductive store, dI/dt in the Explosively Formed Fuse and the fuse load, and a voltage signal which is switch voltage until the closing switch actuates and fuse voltage thereafter. A pulse compression of ~ 50 is illustrated, although compression of ~ 100 has been achieved and we do not believe we have approached a limit. The switch begins to open while carrying a current of 4.6 MA, and the closing switch is not actuated until the system current has dropped to 4.5 MA. Switch dI/dt is -1.3 MA/ μs when the closing switch closes, and further drops to -3.6 MA/ μs as current is transferred to the fuse. Fuse dI/dt jumps abruptly to 2 MA/ μs on switch closure, then peaks at ~ 2.5 MA/ μs . It then drops near zero as current transfer nears completion, and drops again as

the fuse becomes resistive. The voltage waveform shows that the switch voltage reaches 78 kV before the closing switch actuates, then drops abruptly. After the closing switch actuates, the probe is suddenly measuring $I_f R_f$ which is initially small, then climbs as the fuse resistance increases. The switch dissipated 450 kJ in this test during the opening process.

Actuating the closing switch after the opening switch resistance has increased substantially has implications for fast pulse applications. For a circuit with all constant elements consisting of an inductive store, L_o , and an opening switch (represented by an inductance L_{sw} and resistance R_{sw}) in parallel with a pure inductive load, L_l , current is transferred to the load according to

$$I_l = \frac{L_o}{L_o + L_l} I_o \quad 1 - e^{-(t-t_o) R_{sw}/L} \quad (1)$$

where I_o is the current flowing in the switch at t_o and L is the reduced inductive given by

$$L = \frac{L_o L_{sw} + L_o L_l + L_{sw} L_l}{L_o + L_l} \quad (2)$$

We have demonstrated⁴ that using an average value to represent a dynamic resistance gives reasonably good agreement when comparing experimental data to this simple equation. In this light, the pulse transfer time does not depend on the resistance risetime, but on the magnitude of the resistance. Since we have demonstrated that large voltages can be held off across the Explosively Formed Fuse before the closing switch is actuated, we have demonstrated to some degree a faster pulse transfer capability. The average opening switch resistance during the first microsecond after switch closure is $\sim 45 \text{ m}\Omega$, and our reduced inductance is $\sim 27 \text{ nH}$. As a result, $\sim 80\%$ of the available current should be transferred during that time. This is in reasonable agreement with the data. Allowing the resistance to climb even further before closing the switch will lead to even faster current pulses, and it will be appropriate to test for the ultimate open circuit voltage of this device. From small scale tests we expect this to be between 150 and 200 kV.

CYLINDRICAL SWITCH EXTRAPOLATION

Using the data from the experiments described above we can design a switch for higher current applications. We assume that resistance varies as the number of anvils in the die divided by the circumference of the switch. We also assume that the energy we can dissipate in the switch is proportional to the product of the number of anvils in the die and the circumference. Finally, the voltage holdoff should be proportional to the number of anvils. The largest cylindrical detonation system currently available to us is 76 cm long and 96 cm in circumference. This allows us to use 100 anvils of the die pattern described which is five times the number in our smaller scale switch. In addition, the circumference is increased by a factor of 3.3. The switch scaled to these dimensions will have impressive capabilities. The limit of energy dissipation in this switch should exceed 7 MJ, while the resistance achieved should be increased by 1.5. It is likely that both of these scaling factors are conservative since loss of performance due to end effects in the explosive system probably exceeds 10% in the short switch, but will be negligible in the long switch.

The switch can be built to withstand the voltage required of it with an inductance, L_{sw} , of ~ 33 nH. With a fuse load inductance, L_f , of 10 nH, an inductive store, L_o , of 160 nH and energy dissipation given from conservation of flux arguments by

$$\Delta E = \frac{1}{2} I_o^2 \frac{L_o L_{sw} + L_o L_f + L_{sw} L_f}{L_o + L_f} \quad (3)$$

where I_o is the current at switch time, 7 MJ dissipation allows a switch current of 18 MA. When operated as in the test described above, some energy is dissipated before actuating the closing switch, and we will likely operate at currents of 15 MA or less. The linear current density in the test described was 0.16 MA/cm, which scales to 15.2 MA for the large switch. As a result, we expect the rate of resistance rise in ~ 15 MA large scale switch tests to be proportional to the resistance rise in our smaller cylindrical tests. By scaling up the data of Fig. 6 the voltage at closing switch time will be ~ 400 kV. If the switch current is 15 MA, then 400 kV implies a switch resistance of 27 m Ω . The average switch resistance over the next microsecond should be 60-70 m Ω , and as a result, to transfer two e-foldings of current in less than 1 μ s to a load, the reduced inductance described in Eq. 2 must be 30-35 nH. The reduced inductance in the experiment we are planning will be ~ 50 nH, and as a result, only ~ 9 MA ($0.7I_o$) will be transferred in 1 μ s. This, nevertheless, represents a pulse compression for the explosive generator system we are using of 300 to 400. In addition, if a fuse similar to that shown in Fig. 4 were attached as a second stage opening switch, currents of ~ 15 MA could be transferred to the fuse from the large storage inductor, and the opening time of the fuse should be on the order of 200 ns. Operationally, this requires withstanding voltages on the order of megavolts, which we are not currently prepared to handle with our load. We believe, however, that such voltages could be input to suitable high impedance loads.

REFERENCES

1. I. M. Vitkovitsky, D. Conte, R. D. Ford, and W. F. Lupton, Naval Research Laboratory Memorandum Report 4168, March 5, 1980.
2. J. H. Goforth, A. H. Williams and S. P. Marsh, "Multi-megampere Current Interruption From Explosive Deformation of Conductors," Proceedings of the 5th IEEE Pulsed Power Conference, June 1985, P. J. Turchi and M. F. Rose, Eds., pp. 200-203.
3. R. S. Caird, D. J. Erickson, C. M. Fowler, B. L. Freeman, and J. H. Goforth, "A Circuit Model for the Explosive-Driven Plate Generator," Ultrahigh Magnetic Fields-Physics, Techniques and Applications, V. M. Titov and G. A. Shvetsov, Eds. Moscow: Nauka, 1984, pp. 246-253.
4. J. H. Goforth, "Multimegampere Operation of Plasma Compression Opening Switches in Planar Geometry," Proceedings of the 5th IEEE Pulsed Power Conference, June 1985, P. J. Turchi and M. F. Rose, Eds., pp. 212-215.