

LA-9283-MS

CIC-14 REPORT COLLECTION
REPRODUCTION
COPY

Los Alamos National Laboratory is operated by the University of California for the United States Department of Energy under contract W-7405-ENG-36.

LOS ALAMOS NATIONAL LABORATORY



3 9338 00312 9912

Bidirectional Slapper System

Los Alamos

Los Alamos National Laboratory
Los Alamos, New Mexico 87545

Photocomposition by Jo Ann Painter

DISCLAIMER

This report was prepared as an account of work sponsored by an agency of the United States Government. Neither the United States Government nor any agency thereof, nor any of their employees, makes any warranty, express or implied, or assumes any legal liability or responsibility for the accuracy, completeness, or usefulness of any information, apparatus, product, or process disclosed, or represents that its use would not infringe privately owned rights. References herein to any specific commercial product, process, or service by trade name, trademark, manufacturer, or otherwise, does not necessarily constitute or imply its endorsement, recommendation, or favoring by the United States Government or any agency thereof. The views and opinions of authors expressed herein do not necessarily state or reflect those of the United States Government or any agency thereof.

LA-9283-MS

UC-38

Issued: October 1982

Bidirectional Slapper System

Ernest C. Martinez
James H. Goforth



BIDIRECTIONAL SLAPPER SYSTEM

by

Ernest C. Martinez and James H. Goforth

ABSTRACT

A unique bidirectional "slapper detonator" has been demonstrated. A single bridge foil propels two flyers in opposite directions, thereby initiating two explosive pellets. Its use in producing a nearly perfect spherically expanding detonation front is shown.

I. INTRODUCTION

Slapper detonators and their function have been described¹ in terms of their construction: substrate, foil bridge, flyer, barrel, and acceptor explosive pellet. The similarity of the substrate-bridge-flyer part to a propellant-fired gun is evident. In each, an action/reaction occurs between the velocity and mass of the bullet (or flyer) and the velocity and mass of the gun (or substrate). The energy going into the reaction mass is, in a sense, lost. In this work, we reasoned that the "lost" reaction energy might be used to propel a second flyer, a bidirectional slapper, initiating a second acceptor pellet in the opposite direction. This report describes the construction of this device, some of our observations of it, and how it is used to initiate the center of a spherical charge. A patent application is being reviewed in Washington, DC.

II. BIDIRECTIONAL SLAPPER CIRCUIT DESCRIPTION

Figure 1 shows a single-bridge bidirectional slapper circuit that is etched from approximately 4.6- μm Microclad copper on either 25.4- μm - or 50.8- μm -thick Kapton. The circuit etched on 50.8- μm Kapton is easier to handle during construction of the circuit because of the thicker Kapton.

III. BIDIRECTIONAL SLAPPER CIRCUIT CONSTRUCTION

Construction of the cable circuit is seen in Fig. 2. The circuit is folded on itself, around an insulating film. Without the indicated relief, the resulting laminate would become an ordinary unidirectional slapper. The relief hole permits the Kapton on the ground return side of the assembly to be laminated directly onto the bridge. Thus the bridge is covered on both sides with just 25.4 μm (or 50.8 μm) of Kapton (plus a thin layer of glue on one side), and slapper detonators can be built on both sides of it. Special care must be taken to make the layer of glue between the bridge and the flyer very thin so that the flyer with the glue is propelled with nearly the same velocity as that without glue. A 25.4- μm sheet of polyester cast adhesive glues the opposite side flyer onto the bridge. During the laminating process the adhesive thins to approximately half its original thickness. Thinner glue layers can be obtained with wet adhesives, but this technique does not lend itself to current production operations and has not been pursued.

IV. BIDIRECTIONAL DETONATOR SYSTEM

Figure 3 describes the components in a bidirectional detonation system. Sapphire barrels are placed on both sides of the slapper cable to help direct the Kapton flyer

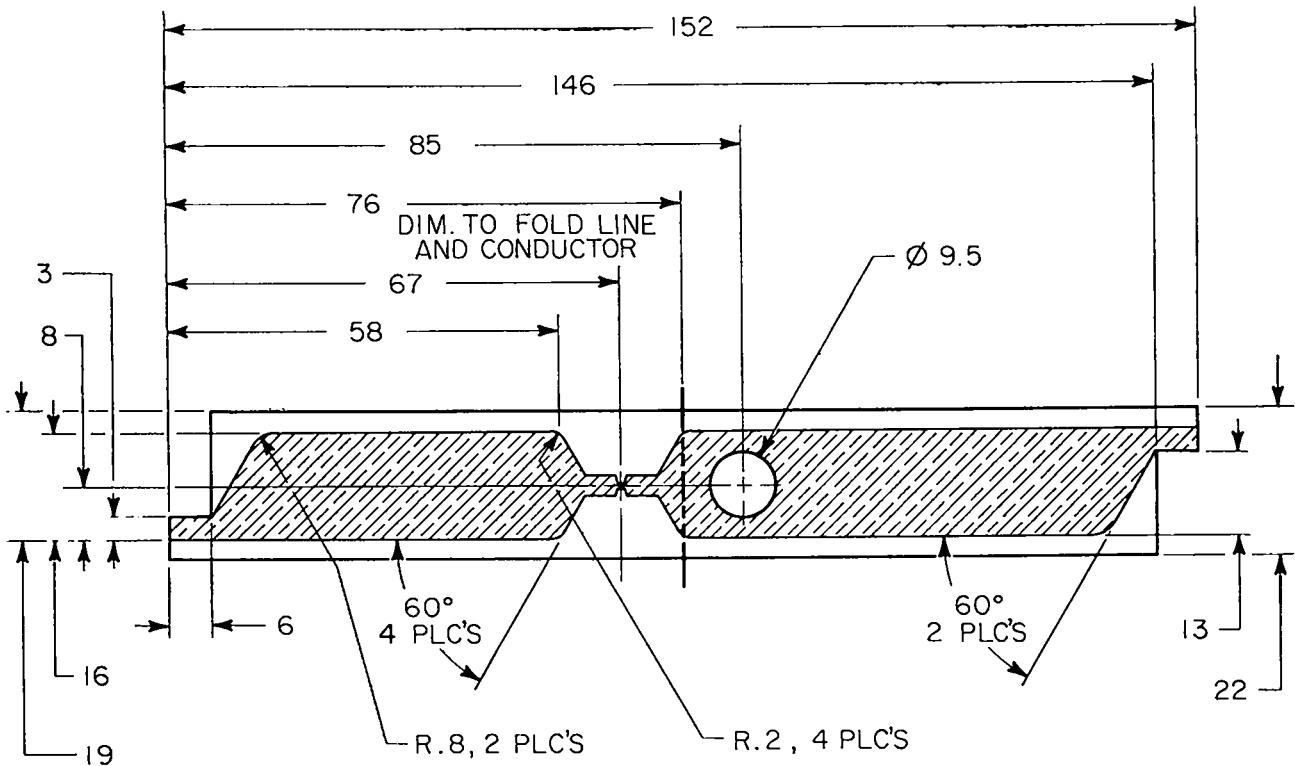

Fig. 1. Bidirectional slapper circuit (dimensions in millimeters).

to hit the explosive pellet. A barrel holder, made of Artus shimstock material, holds the small barrel in place. Advantages of this type of barrel are that it is small, perfectly round, and rather inexpensive. The explosive pellets are placed directly over the sapphire barrel, which is approximately 0.039 mm longer than the barrel holder to ensure that there is no gap between the barrel and the explosive pellet.

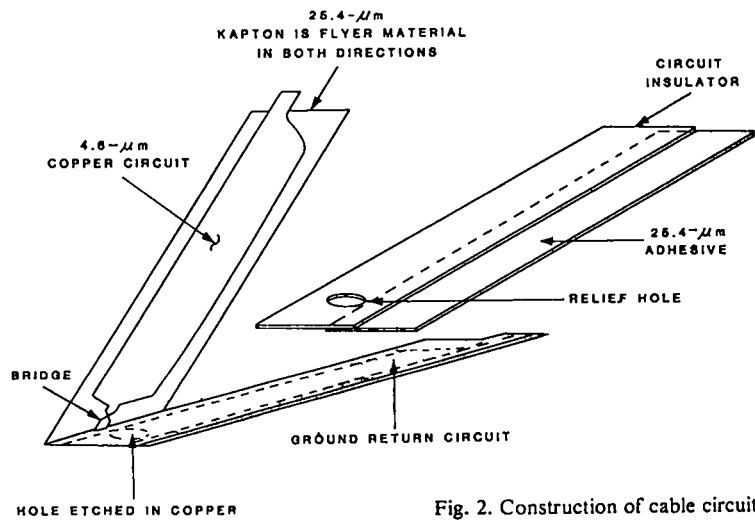
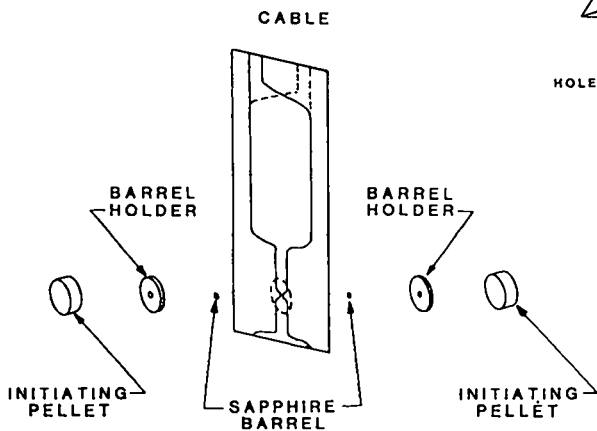

Fig. 2. Construction of cable circuit.



- Fig. 3. Bidirectional slapper detonator system components.
- Bridge: 0.381-mm-square bridge, 4.6- μ m-thick copper
 - Pellet: 1.65-g/cm³ PETN, 3 mm long by 12.7 mm in diam
 - Barrel holder: 9.52 mm in diam by 0.318 mm long, 0.965-mm-diam hole
 - Barrel: Sapphire, 0.965 mm in diam by 0.356 mm long, 0.406-mm-diam hole
 - Flyer: 25.4- μ m Kapton on both sides of bridge

V. EXPLOSIVE INITIATION USING A BIDIRECTIONAL SLAPPER SYSTEM

Assemblies like that shown in Fig. 3 were tested to determine the difference in timing between the pellet fired with the glued flyer and that fired with the laminated

flyer. Figure 4 shows how these assemblies were viewed by the streak camera.

The streak camera is focused on the mirror images so the sides of the pellets are seen as a blurred image in the photo and dynamic record. A set of recorded film traces is shown in Fig. 5.

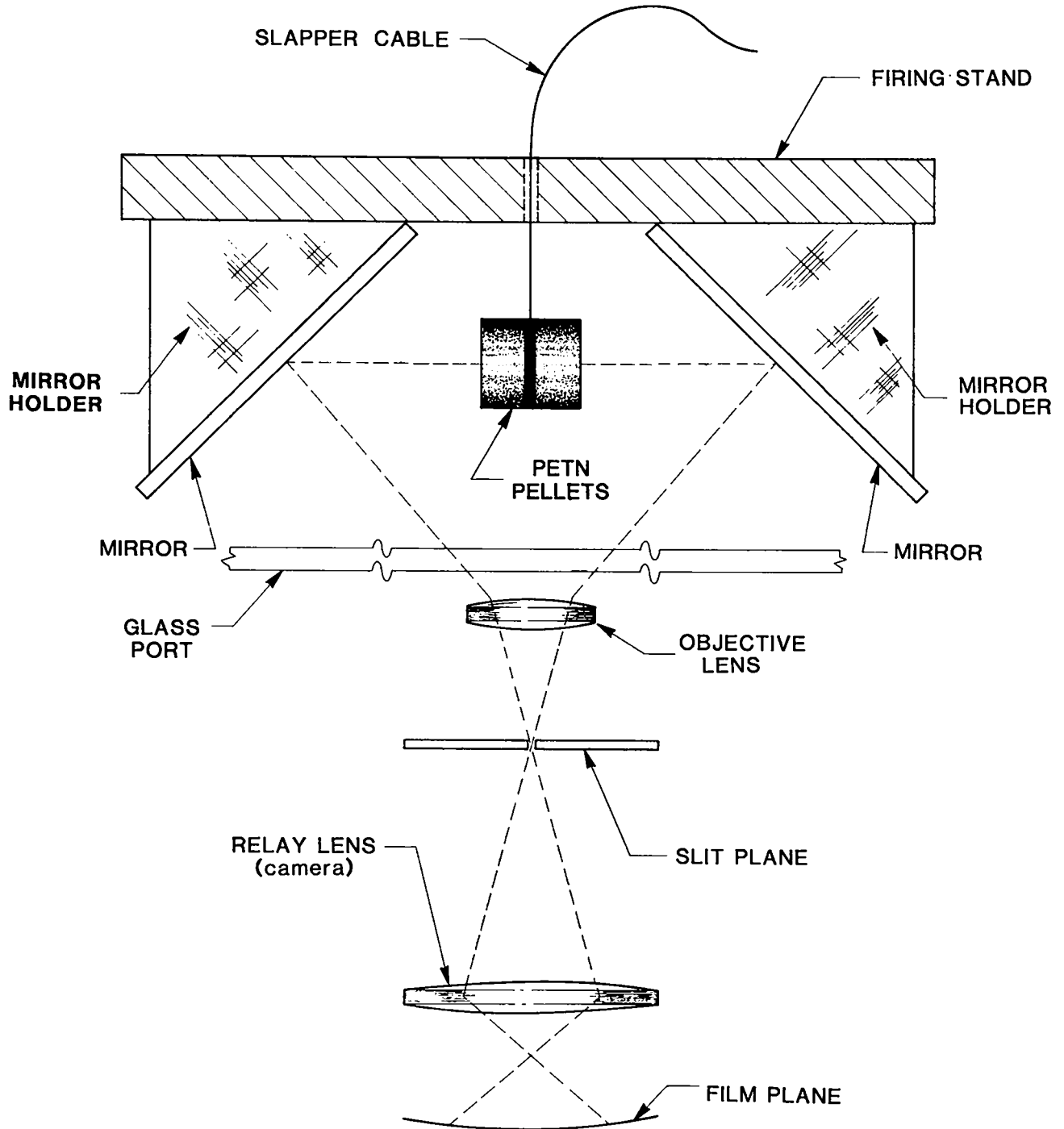

Fig. 4. Streak camera view of bidirectional assembly.

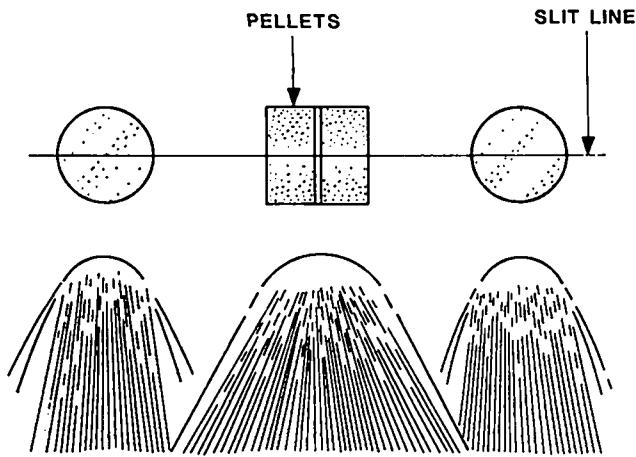

Fig. 5. Recorded film traces.

Bidirectional slapper assemblies were fired using two types of capacitor discharge units (CDUs), charged to different voltages, at both ambient temperature and at -54°C to test the system over a wide temperature range. Table I lists test results of a number of these experiments. Bias time is the time from breakout of the pellet being initiated with the unglued flyer to the breakout time of the pellet fired by the glued flyer. Table I shows that all assemblies fired well at ambient temperature, except those fired near the threshold voltage. Best results at -54°C were achieved with the larger firing unit.

VI. IHE INITIATION WITH THE BIDIRECTIONAL SLAPPER SYSTEM

We have demonstrated that the bidirectional slapper system is capable of good performance when initiating an IHE (insensitive high explosive) acceptor charge at cold temperature. Figure 6 shows a bidirectional slapper

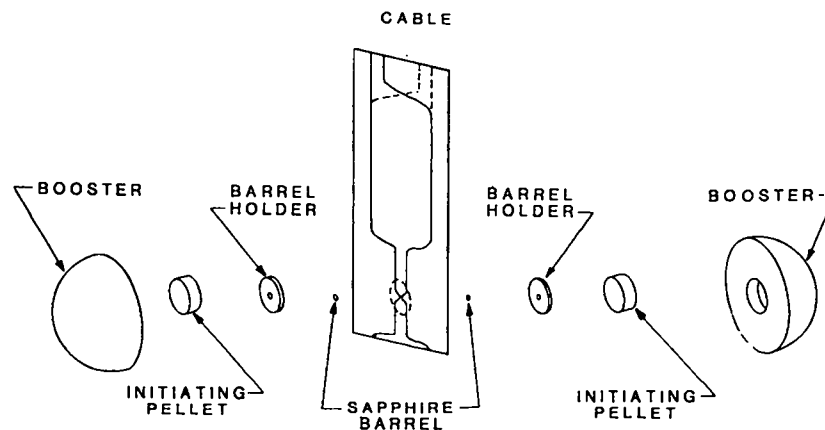

Fig. 6. Bidirectional slapper system using 1.8-g/cm^3 TATB hemispherical booster pellets.

TABLE I. Results of Experiments Using Two Types of CDUs

CDU (Type) (μF)	Temperature	Firing Voltage (V)	Bias Time (μs)
0.2	Ambient	6000	0.017
0.2	Ambient	6000	0.015
0.2	Ambient	6000	0.011
0.2	Ambient	5000	0.033
0.2	Ambient	4000	0.258
0.2	-54°C	6000	0.086
2.0	Ambient	6000	0.014
2.0	Ambient	6000	0.025
2.0	-54°C	6000	0.040
2.0	-54°C	5000	0.297

system using 1.8-g/cm^3 TATB hemispherical booster pellets. The hemispherical pellets are machined to accommodate the sapphire barrels and initiating pellets and allow them to be embedded in the IHE.

Figure 7 shows that the assembled components create an almost perfect spherical assembly, except for the thickness (0.127 mm) of the slapper cable.

In this type of assembly, each detonation wave must spread in a hemispherical fashion. To best achieve this goal, the size of the acceptor pellet is adjusted experimentally.

Several experiments were conducted using 12.7-mm-diam initiating pellets of different lengths. Figure 8 shows such an experiment as viewed by the streak camera.

Figures 9a-c show film traces of experiments using different lengths of PETN pellets to light spherical assemblies of 1.8-g/cm^3 Micronized TATB. An ideal spherically expanding detonation wave produces

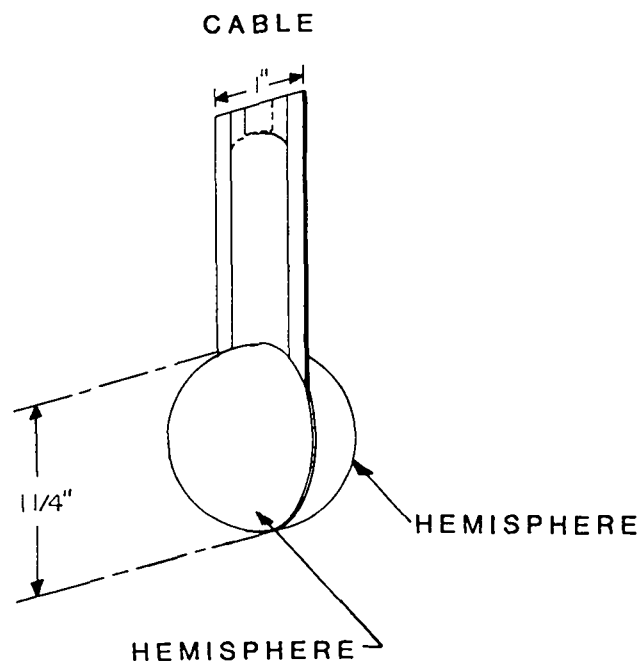

Fig. 7. Spherical assembly bidirectional slapper detonating system.

perfectly flat traces. Figure 9a shows traces of an experiment using 3-mm-long pellets. Tests have shown that the smallest 1.65-g/cm³ PETN pellets that promptly initiate 1.8-g/cm³ Micronized TATB at -54°C are 3 mm long by 12.7 mm in diameter. Both traces are relatively flat; except the side initiated with the glued flyer initiated approximately 0.060 μs later than the side with the unglued flyer. Figure 9b shows film traces of an experiment using 4-mm-long initiating pellets. The results are very similar to those from the experiment using 3-mm-long pellets. The side with the glued flyer is approximately 0.050 μs later than the other.

Figure 9c shows film traces of an experiment using 5.689-mm-long PETN pellets. The hemispherical pellets were machined to a depth of 6 mm, then the PETN pellets were pressed to a length that enabled both the sapphire barrels and initiating pellets to be embedded in the acceptor material to form an almost perfect spherical assembly. We obtained the best results from this experiment. The traces are very flat, with both sides firing at approximately the same time. Experiments show that initiating pellets longer than 6 mm produce very uneven waveforms in the IHE.

VII. BIDIRECTIONAL SLAPPER ASSEMBLIES WITHOUT BARRELS

Hemsing² has shown that the high-tolerance barrel assemblies described earlier can be replaced by a spacer,

which results in fewer critical dimensions and no critical positioning. The spacers have a hole much larger than the bridge, which relieves the need for critical positioning and for high-quality barrel edges.

The spacers are also short enough that the slapper never shears from the Kapton sheet but contacts the explosive while still in the form of a bubble on the Kapton surface. The larger area apparently compensates for the slower slapper velocity caused by the shorter acceleration. In the future we plan to use this type of design in slapper type detonator assemblies.

VIII. CONCLUSIONS

We have demonstrated that a bidirectional slapper system can be built that will initiate pellets in both directions with or without barrels, and do so with small energy requirements. This kind of system will initiate IHE in both directions, at cold temperatures, and achieve good spreading when initiating Micronized TATB hemispherical pellets.

ACKNOWLEDGMENTS

We thank W. H. Meyers and W. F. Hemming for many helpful discussions, W. Hicks for his help in assembling the slapper circuits, and L. Rico for skillful experimental assistance.

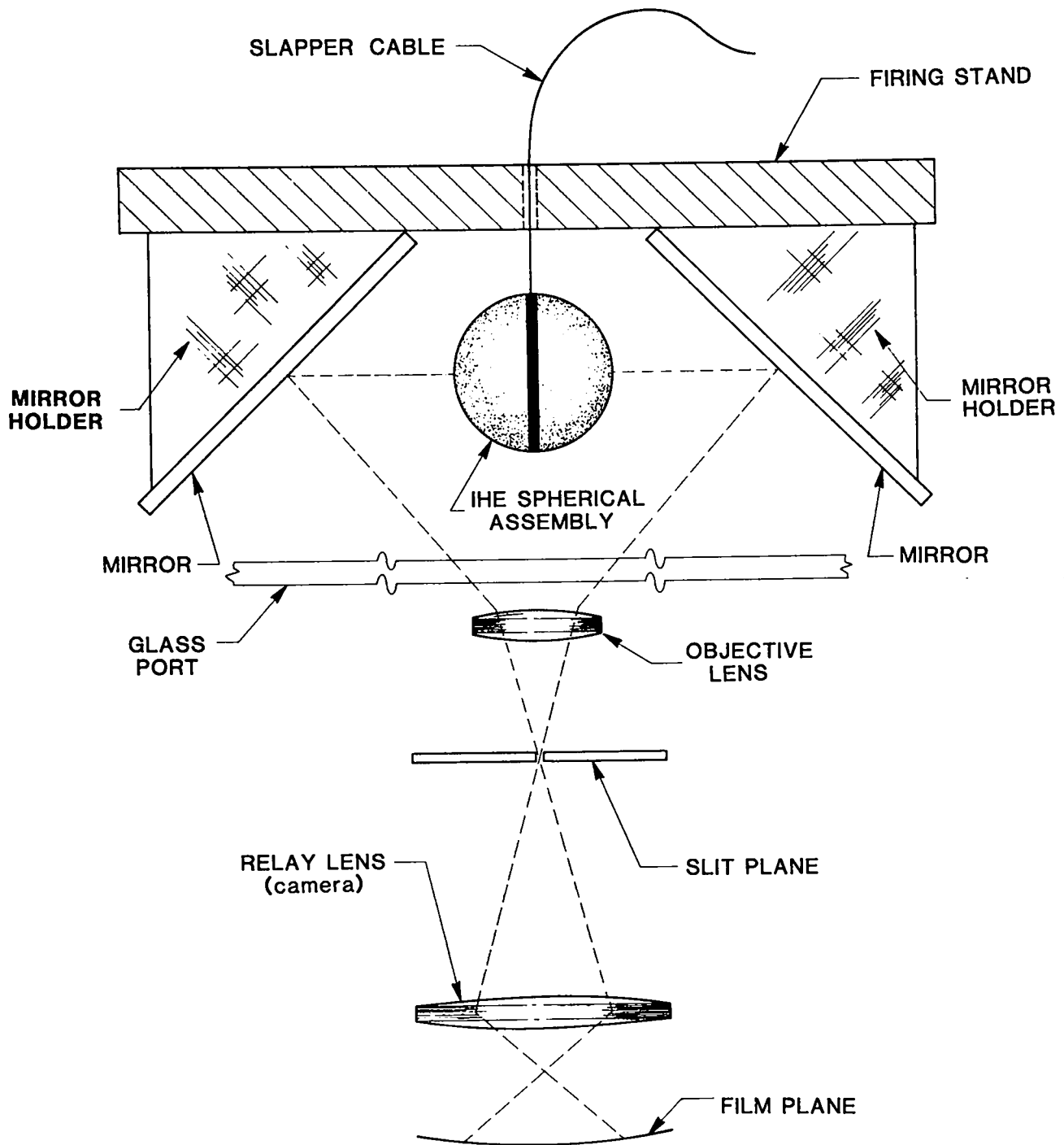

Fig. 8. Streak camera view of hemispherical assembly.

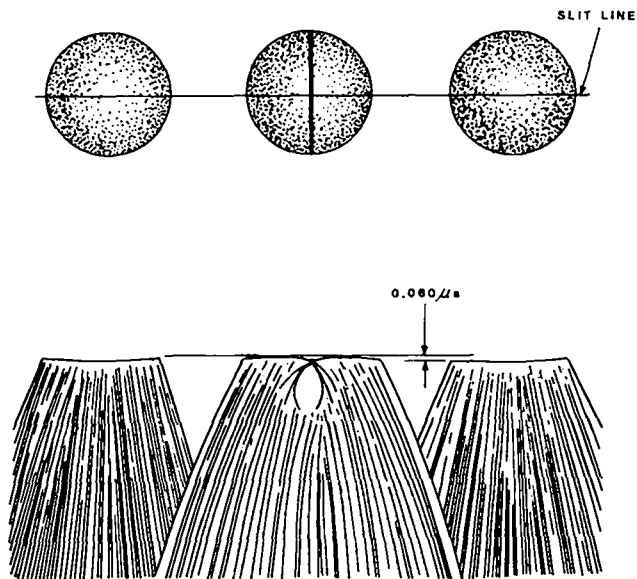

Fig. 9a. Initiating pellets 3 mm long.

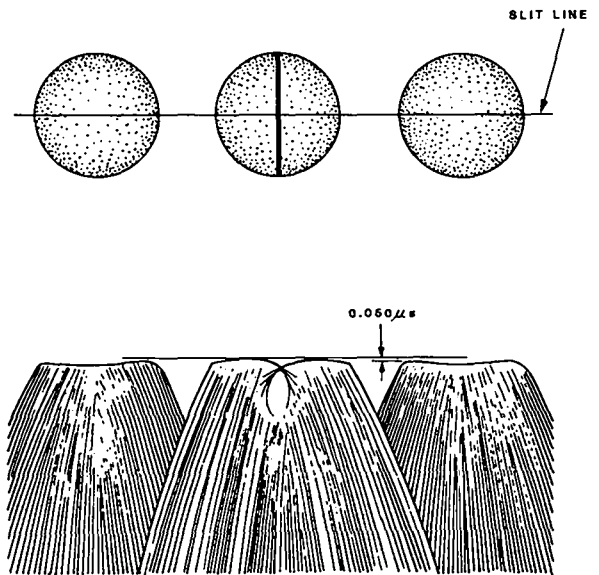

Fig. 9b. Initiating pellets 4 mm long.

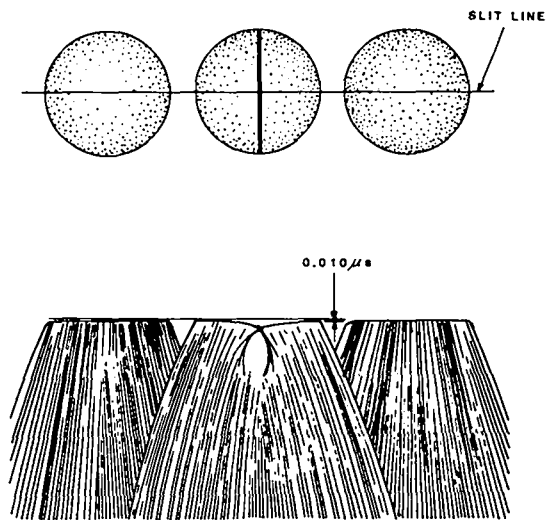

Fig. 9c. Initiating pellets 5.689 mm long.

REFERENCES

1. T. J. Tucker and P. L. Stanton, "Electrical Guernsey Energy; A New Concept in Modeling of Energy Transfer from Electrically Exploded Conductors," Sandia Laboratories report SAND 75-0244 (May 1975).
2. W. F. Hemsing, "Slapper Detonator Modification," Proc. Ninth Annual Joint Firing Systems Conf., Los Alamos National Laboratory, October 6, 1981.

Printed in the United States of America
Available from
National Technical Information Service
US Department of Commerce
3285 Port Royal Road
Springfield, VA 22161

Microfiche (A01)

Page Range	NTIS Price Code	Page Range	NTIS Price Code	Page Range	NTIS Price Code	Page Range	NTIS Price Code
001-025	A02	151-175	A08	301-325	A14	451-475	A20
026-050	A03	176-200	A09	326-350	A15	476-500	A21
051-075	A04	201-225	A10	351-375	A16	501-525	A22
076-100	A05	226-250	A11	376-400	A17	526-550	A23
101-125	A06	251-275	A12	401-425	A18	551-575	A24
126-150	A07	276-300	A13	426-450	A19	576-600	A25
						601-up*	A99

*Contact NTIS for a price quote.



Los Alamos