

LA-1191

Series A

LOS ALAMOS NATL. LAB. LIBS



3 9338 00339 3732

UNCLASSIFIED

[REDACTED]

[REDACTED]

ENTIRE OF THE DOCUMENT MUST BE COVERED BY A RECEIPT.
IT MUST NOT BE UNATTENDED OR WHERE AN AUTHORIZED PERSON
MAY HAVE ACCESS TO IT. WHEN NOT IN USE, IT MUST BE STORED IN A LOCKED
FILE OR SAFE. WHILE THIS DOCUMENT IS IN YOUR POSSESSION AND UNTIL YOU
HAVE OBTAINED A RECEIPT UPON ITS TRANSFER TO AN AUTHORIZED
INDIVIDUAL, IT IS YOUR RESPONSIBILITY TO KEEP IT AND ITS CONTENTS FROM
AN UNAUTHORIZED PERSON.

[REDACTED]

CONTAINS INFORMATION AFFECTING THE NATIONAL DEFENSE
OF THE UNITED STATES. THE DISCLOSURE OF ITS CON-
TENTS IN ANY MANNER TO AN UNAUTHORIZED PERSON IS PROHIBITED AND MAY
INCUR SEVERE CRIMINAL PENALTIES UNDER APPLICABLE FEDERAL

[REDACTED]

[REDACTED]

[REDACTED]

LOS ALAMOS NATIONAL LABORATORY



3 9338 00339 3732

[REDACTED]

UNCLASSIFIED

UNCLASSIFIED

~~SECRET~~
SECRET

UNCLASSIFIED

LOS ALAMOS SCIENTIFIC LABORATORY
of
THE UNIVERSITY OF CALIFORNIA

PUBLICLY RELEASABLE
LANL Classification Group
[Signature]
12/1/95

January 1, 1951

LA-1191

This document consists of 59 pages
~~SECRET~~

Classification changed to UNCLASSIFIED
by authority of the U. S. Atomic Energy Commission.

Per ALDR(TID-1400-S2)Sept-Oct 1974

By REPORT LIBRARY *[Signature]* 3/6/75

THE FABRICATION OF LITHIUM

	Reviewers	Class.	Date
SPECIAL REREVIEW	<u>WHL</u>	<u>U</u>	<u>4/7/82</u>
FINAL DETERMINATION	<u>SAU</u>	<u>U</u>	<u>"</u>
Class: <u>U</u>			

VERIFIED UNCLASSIFIED

Per ZMS 6-14-79

By [Signature] 12/14/95

Work Done By:

- G. E. Jaynes
- G. S. Hanks
- R. Osborne
- G. Sweeney
- V. Vigil

Report Written By:

- G. E. Jaynes
- G. S. Hanks
- J. M. Taub
- D. T. Doll

Family Developments

~~SECRET~~
SECRET

UNCLASSIFIED
UNCLASSIFIED

~~SECRET~~

UNCLASSIFIED

~~SECRET~~

APR 21 1951

LA-1191

Washington Document Room
J. R. Oppenheimer
Los Alamos Document Room

1-4
5
6-20

~~SECRET~~

UNCLASSIFIED

~~SECRET~~

UNCLASSIFIED

ABSTRACT

Under operating conditions where-in the metal is protected from excessive reaction with the atmosphere, it has been found practical to roll, extrude, cast, and weld lithium. The work has been narrow in scope in that small quantities (in the order of a few pounds) of metal were used in the several experiments.

The fundamental purpose of the work was to investigate means of fabricating lithium in view of possible later requirements. No exhaustive study was made of process variables. Only sufficient work was done to indicate that the proposed forming of the metal could be done.

~~SECRET~~

UNCLASSIFIED



UNCLASSIFIED

General Discussion

Lithium is the lightest of all alkali metals. At room temperature it reacts slowly with moisture and oxygen of the air (1)*. Differing from the other alkali metals, however, lithium combines with nitrogen of the air at ordinary temperatures. This reaction, forming Li_3N , is accompanied by a rise in temperature. At temperatures near its melting point (186°C) lithium may ignite in air and burn with an intense white flame. The principal product of this reaction is lithium oxide which forms an extremely caustic and irritating white cloud. Lithium reacts with hydrogen to form a very stable hydride, and with carbon dioxide to form lithium oxide, lithium carbide and carbon. Solid lithium reacts with water; the lithium hydroxide formed has a comparatively low solubility in water (1).

Lithium has been found to attack stainless steel and to dissolve nickel; sintered quartz is suggested for use as a lithium container up to 285°C (1).

PHYSICAL PROPERTIES OF LITHIUM (5)

Atomic Number	3
Atomic Weight	6.940
Density at 20°C -g/cu cm	0.53
Atomic Volume, Cu Cm/g-atom	13
Melting Point $^\circ\text{C}$	186 ± 5

* All references refer to the Bibliography at the end of this report.

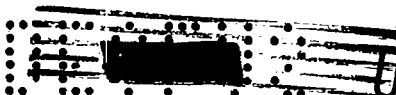

UNCLASSIFIED

SECRET

UNCLASSIFIED

PHYSICAL PROPERTIES OF LITHIUM (Cont'd)

Boiling Point °C	1370
Specific Heat at 20°C cal/g/°C	0.79
Heat of Fusion, cal/g	159
Specific Gravity	0.534
Heat of Fusion, Bt u/lb	286
Coefficient of Linear Thermal Expansion Near 20°C Micro-in./°C	56
Thermal Conductivity near 20°C cal/sq cm/cm/°C/sec	0.17
Electrical Resistivity, microhm-cm	8.55 (0C)
Hardness Moh's Scale	0.06
Volume Change in Fusion	1.5

Metallurgy and Fabrication

Lithium metal can be extruded, rolled into sheet, pressed into wire and welded. The principal difficulties encountered in its fabrication is its susceptibility to corrosion during the fabricating operations. Protection of the surface by immersion in a bath of kerosene before and immediately after rolling helps to limit this corrosive action to a minimum. Varnish, paraffin or some other organic covering may be applied to the finished shape to stop oxidation. In an inert atmosphere, as for example argon or paraffin vapor, lithium can be handled up to 200°C. This permits melting and casting of the metal.

SECRET

SECRET

UNCLASSIFIED

~~SECRET~~
SECRET

UNCLASSIFIED

Lithium and magnesium readily form a solid solution at the lithium-rich end of the system. This alloy is body centered cubic and should work as readily as does lithium. The solidus curve rises gradually from the melting point at 100 percent lithium to about 200°C at 80 atomic percent lithium or about 93 weight percent (1). A satisfactory casting method for preparing the high lithium alloys of magnesium was obtained by packing the alloys in a low carbon steel tube so that the atmosphere in the unit was predominantly lithium and magnesium. Other alloys of lithium have been investigated such as alloying with beryllium. An alloy of 65% lithium and 35 beryllium is as light as water but corrodes easily. By adding small quantities of aluminum or zinc to lithium the hardness, strength, and resistance to corrosion are increased (2).

Purpose of Lithium Investigation:

To determine the feasibility of producing a cylindrical shape having the following dimensions.

<u>Outside diameter</u>	<u>Wall thickness</u>	<u>Length</u>
Approx. one meter	1/4 inch to 1/2 inch	Approx. 6 feet

The shape is to be a self-contained unit which must also allow for enclosure of each end of the cylinder.

Proposed Methods of Fabrication:

1. Direct extrusion of cylindrical shape and subsequent welding of circular plates at each end.

~~SECRET~~
SECRET

UNCLASSIFIED



UNCLASSIFIED

2. Rolling sheet to desired thickness and forming a cylindrical shape, joining of sheet and ends either by hot-iron welding or spot welding.

Procedures and Methods Tried:

Extrusion seemed to be the most direct approach to producing a cylindrical shape. Drawings, Figure 1, and tools, Figure 2, were made to extrude a scale size tube having a one inch outside diameter and 0.010 inch thick wall. A cylindrical billet of lithium 3 inches in diameter and 1/2 inch in thickness was cut from a flattened piece of lithium, and inserted into the lower recess of the die holder, Figure 2. The die was placed in the die holder and the remainder of the parts assembled. The extrusion die and ram assembly were placed on top of the kerosene well, Figure 1, ready for extruding. Equipment used was a Hannifin press, capacity 75 tons. Maximum pressure exerted to extrude the 1 inch O.D. x 0.010 inch wall cylinder was approximately 260 psi. Figure 3 shows two views of extruded lithium tubes.

The results obtained from the preliminary extrusion work were favorable and tools were designed and constructed to cast and extrude a cylinder 13 inches O.D. x 0.100 inch wall; a size approximately 1/3 of the contemplated final shape.

Casting Technique:

A casting mold was designed, Figure 4, to cast a ring 13 $\frac{1}{2}$ inches outside diameter by 12 $\frac{1}{2}$ inches inside diameter and 4 inches in

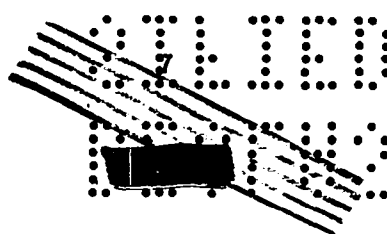

UNCLASSIFIED

UNCLASSIFIED

Figure 1 - Drawing and schematic diagram showing tools and assembly required to extrude a 1.00" O.D. x 0.010" wall cylinder from lithium.

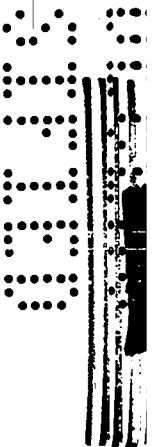

UNCLASSIFIED

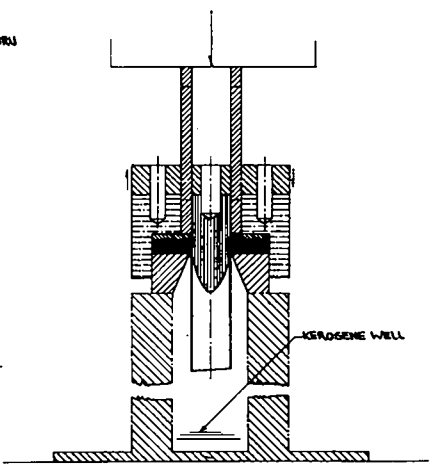

EXTRUSION DIE & RAM ASSEMBLY

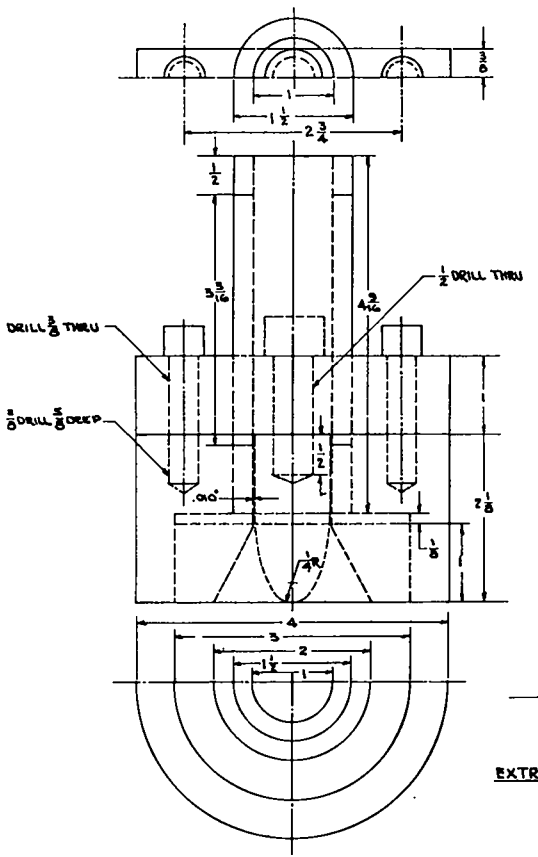

UNCLASSIFIED



UNCLASSIFIED

Figure 2 - PARTS LIST

- A. Die Holder
- B. Die
- C. Dummy Block
- D. Ram guide
- E. Extrusion Ram

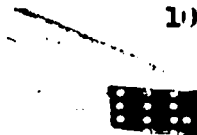

UNCLASSIFIED

SECRET

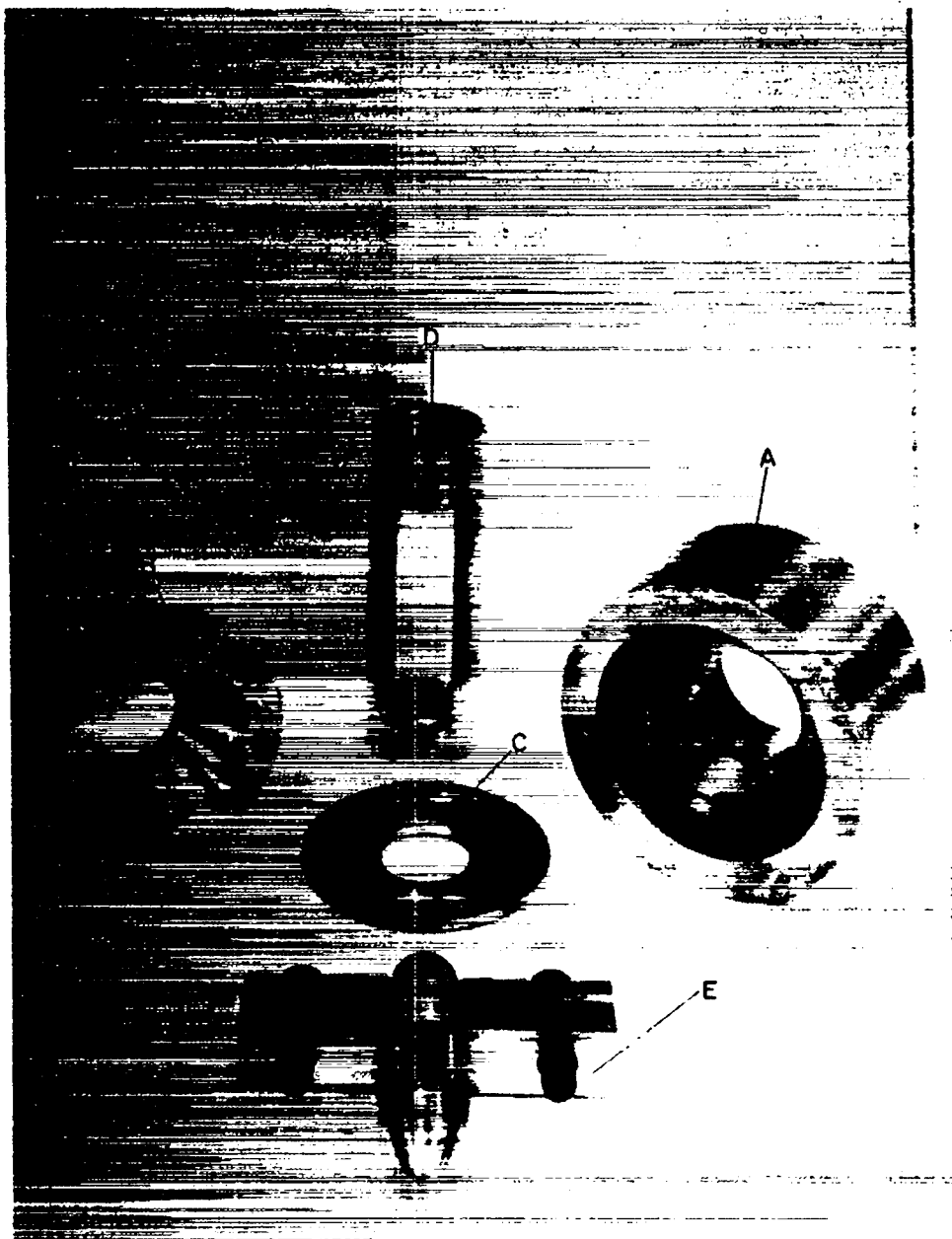

SECRET

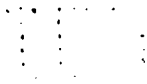

Figure 3 - Two views of 1" outside diameter
x 0.010" wall extruded lithium tubing.



00: [REDACTED]
SIF 10

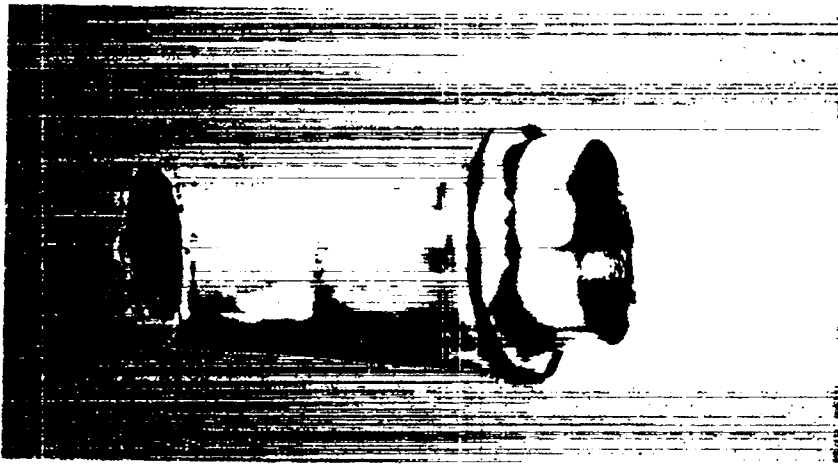
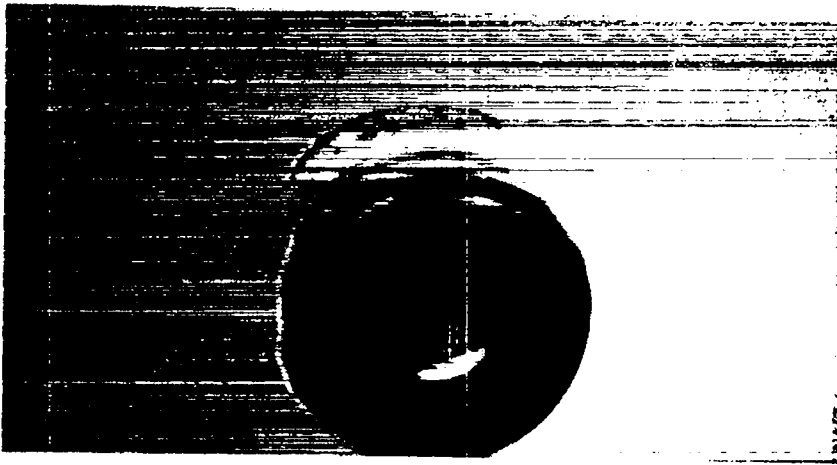

Plate 2/9-5 Macro.
25mm tube, side view.



25mm tube, end view, Macro.

00: [REDACTED]
13. SIF 10
[REDACTED]

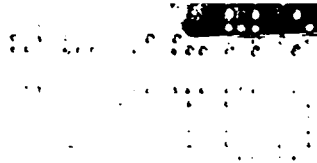

Figure 4 - Detail mold drawing for casting a
lithium ring $13\frac{1}{2}$ " O.D. x $12\frac{1}{2}$ " I.D.
x 4" high.



CONFIDENTIAL

height. A survey of the literature indicated that the association of lithium with iron had the least amount of solubility at elevated temperature (1). Upon this basis, iron was used as the mold material. The design of the mold was made to include a small lip around the inner portion of the mold wall, the purpose being to stack the lithium metal on this surface and as the temperature rose the metal would flow into the mold cavity, thus leaving any oxides formed on this surface. This line of reasoning was well founded from the results obtained after the casting was formed and inspected.

The mold was designed to fit in a resistance type pre-heat furnace. A charge of approximately two pounds of lithium was placed in the mold and the mold placed in the furnace. Temperature control was maintained by one thermocouple from the furnace recorder and a check control by a portable temperature recorder. Time required to bring the lithium metal up to temperature was approximately one hour. The metal was held at temperature (268°C) for one hour and then cooled to room temperature.

Considerable trouble was encountered in trying to remove the cast lithium ring from the steel mold. Apparently the surface of the mold was not properly cleaned as a reference had indicated that mild steel, thoroughly cleaned, was recommended for handling molten lithium (1). At elevated temperature, welded seams and joints are likely to suffer penetration. Steel equipment, in contact with

CONFIDENTIAL

SECRET

molten lithium, is rapidly decarburized. The stainless steels have been considered unsuitable for handling liquid lithium at high temperatures, but the trouble encountered in the past is now believed to have been caused by the presence of lithium chloride, or other contamination of the lithium.

In order to remove the lithium from the mold, it was necessary to cut the lithium and peel it from the steel surface. The two ends of the lithium slab were then cut on a 45 degree bias, butted together and the ring thus formed inserted in the metal space of the extrusion cylinder, Figure 5.

Figures 6 through 10 describe the equipment used to extrude the 13 inch O.D. cylinder.

The extrusion and ram assembly is shown in Figure 11. Extrusion was performed on a 75 ton Hannifin Press. The maximum pressure required to extrude the cylinder was 450 psi. Figure 12 shows the extruded cylinder. Figure 13 shows a photograph of the liquid wax well used.

When the maximum stroke of the ram had been secured, the extruded lithium cylinder was cut off from the lower extremity of the die orifice using a knife and immediately put in the wax well to obtain a protective covering.

The second extrusion run did not use a cast lithium ring. Lithium metal was rolled to approximately 1/2 inch in thickness by 4 inches wide. It required four lengths of the rolled metal to fill

SECRET

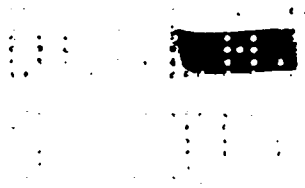
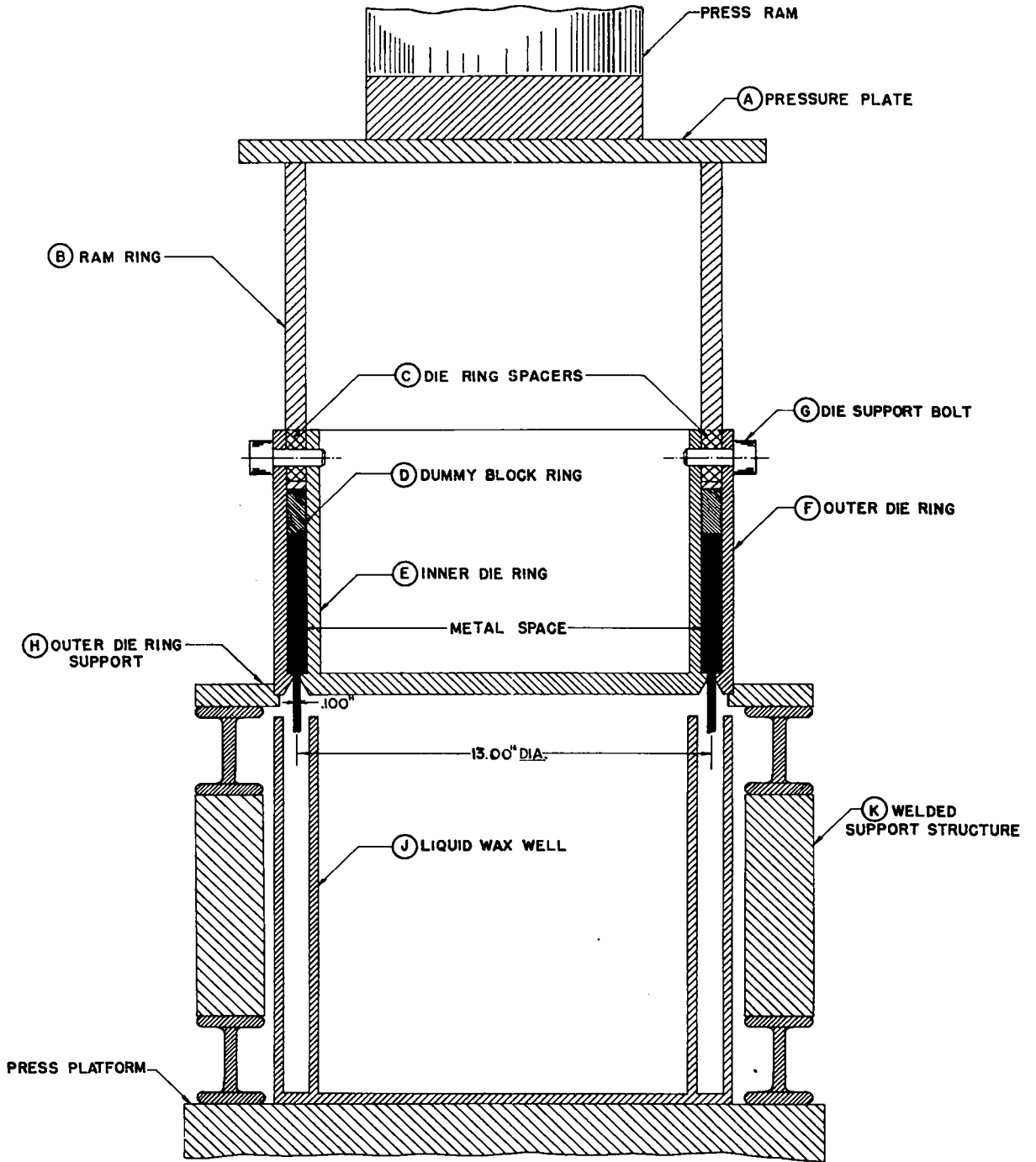

Figure 5 - Schematic drawing of extrusion die
and ram assembly.

SECRET



EXTRUSION DIE & RAM ASSEMBLY

SECRET

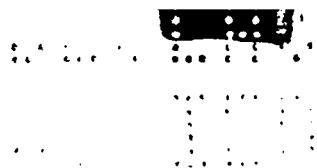
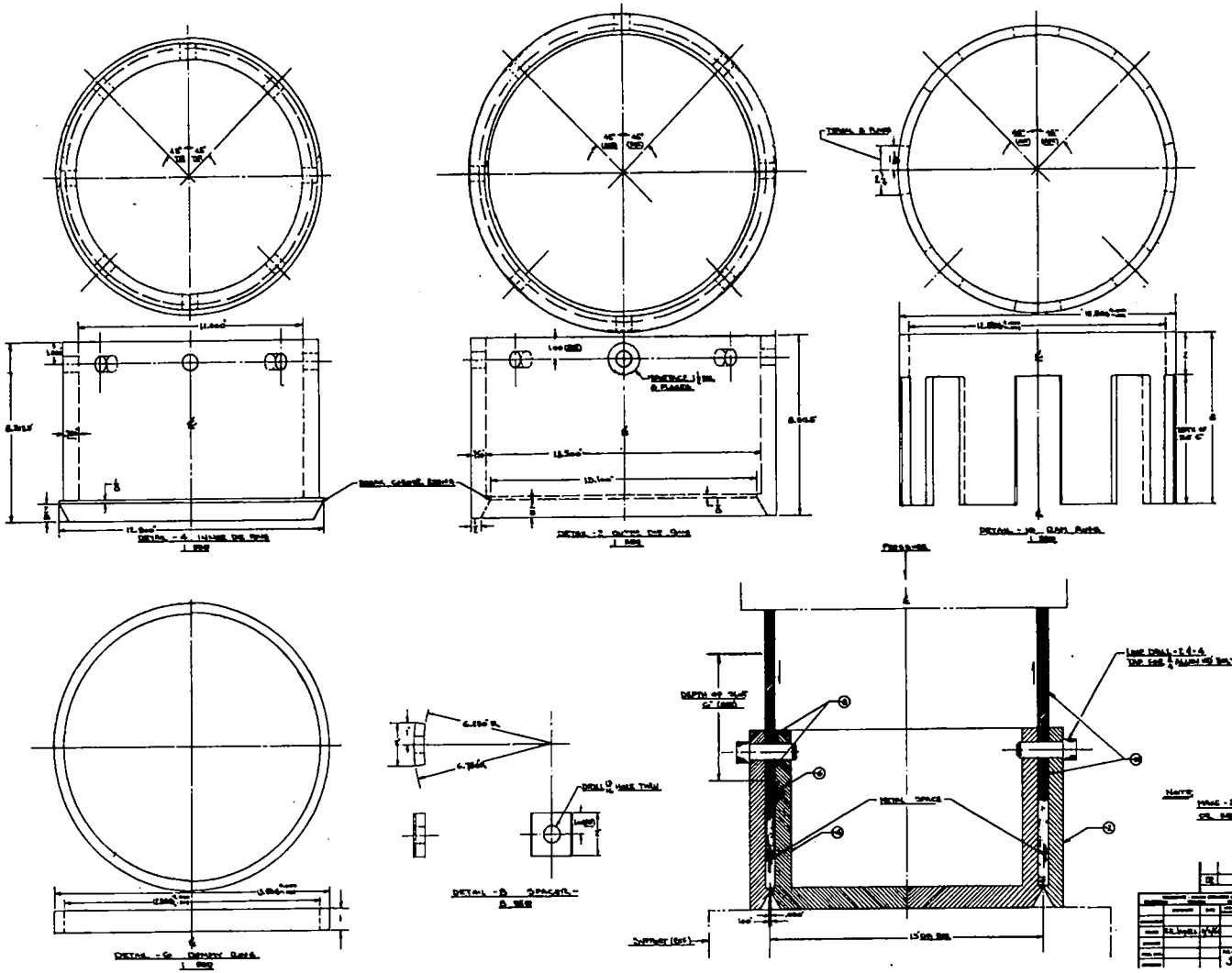

Figure 6 - Extrusion die and ram assembly.



SECRET



NO.	REV.	DATE	BY	CHKD.	DESCRIPTION
1					
2					
3					
4					
5					
6					
7					
8					
9					
10					
11					
12					
13					
14					
15					
16					
17					
18					
19					
20					
21					
22					
23					
24					
25					
26					
27					
28					
29					
30					
31					
32					
33					
34					
35					
36					
37					
38					
39					
40					
41					
42					
43					
44					
45					
46					
47					
48					
49					
50					
51					
52					
53					
54					
55					
56					
57					
58					
59					
60					
61					
62					
63					
64					
65					
66					
67					
68					
69					
70					
71					
72					
73					
74					
75					
76					
77					
78					
79					
80					
81					
82					
83					
84					
85					
86					
87					
88					
89					
90					
91					
92					
93					
94					
95					
96					
97					
98					
99					
100					

SECRET

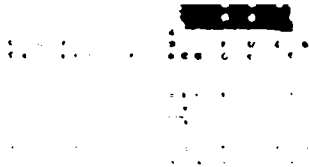
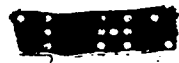
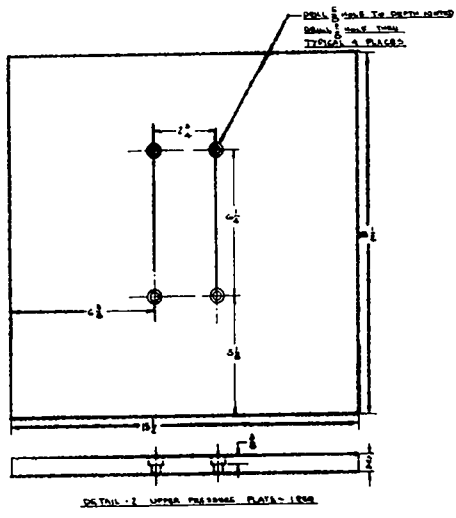
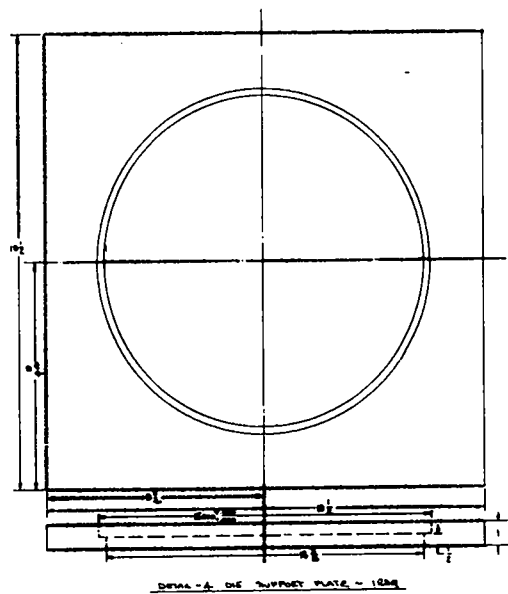

Figure 7 - Detail drawing of pressure plate (A)
and die support (H).



SECRET



NOTE: MAKE 12.4 - B FROM 1010 CO. DIE PLATE

REV	DATE	BY	CHKD	DESCRIPTION
1				EXTENDING DIE SUPPORT & PRESSURE PLATE
2				
3				
4				
5				
6				
7				

SECRET



Figure 8 - Detail drawing of liquid wax well.

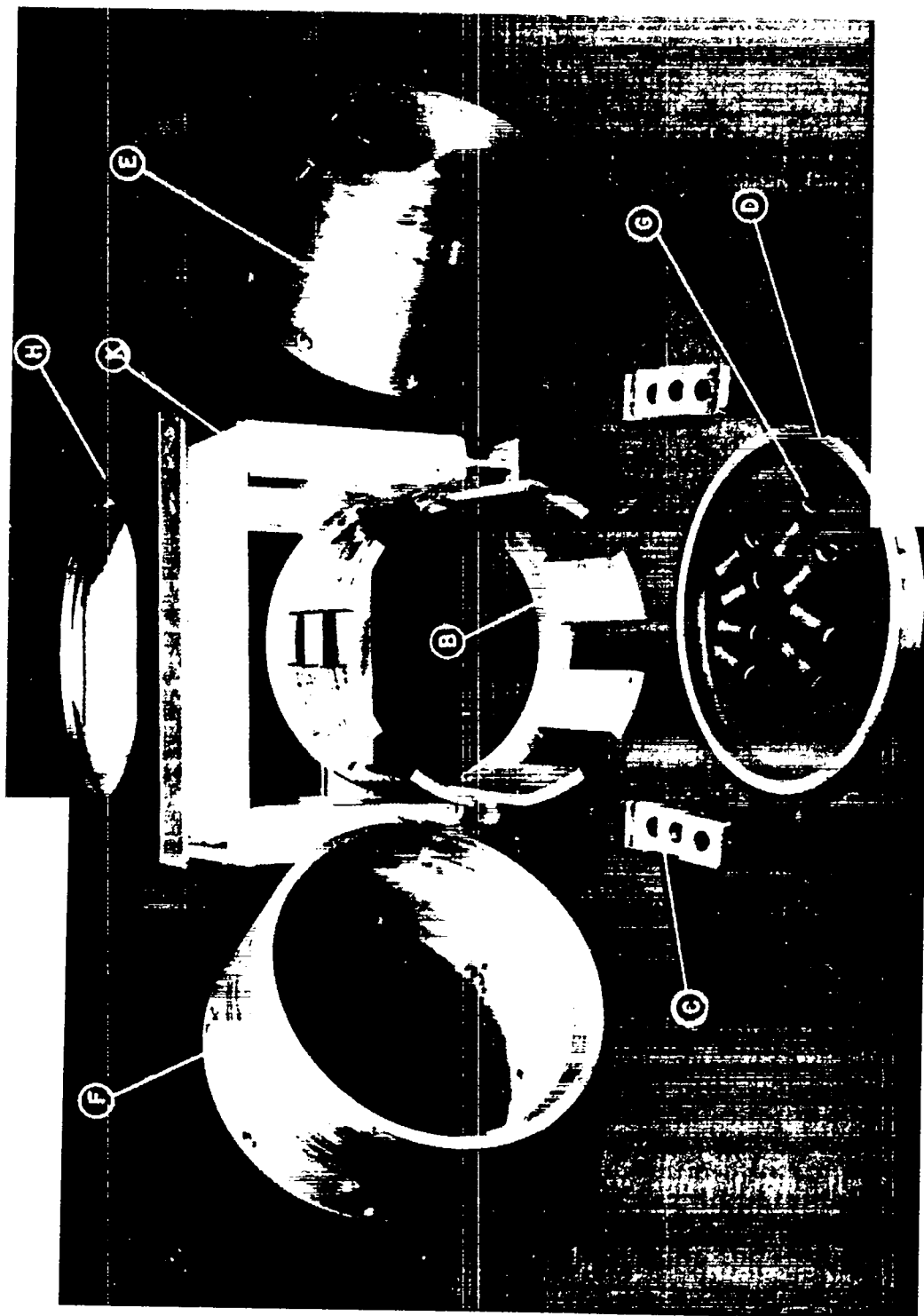



Figure 9 - Photograph of component parts for
extrusion and ram assembly. See
Figure 5 for detail description of
each part.



01 100
27
01 100



01 100
27
01 100



Figure 10 - Photograph showing (B) ram,
(D) Dummy Block, (E) Inner die
ring, (F) Outer die ring.



SECRET

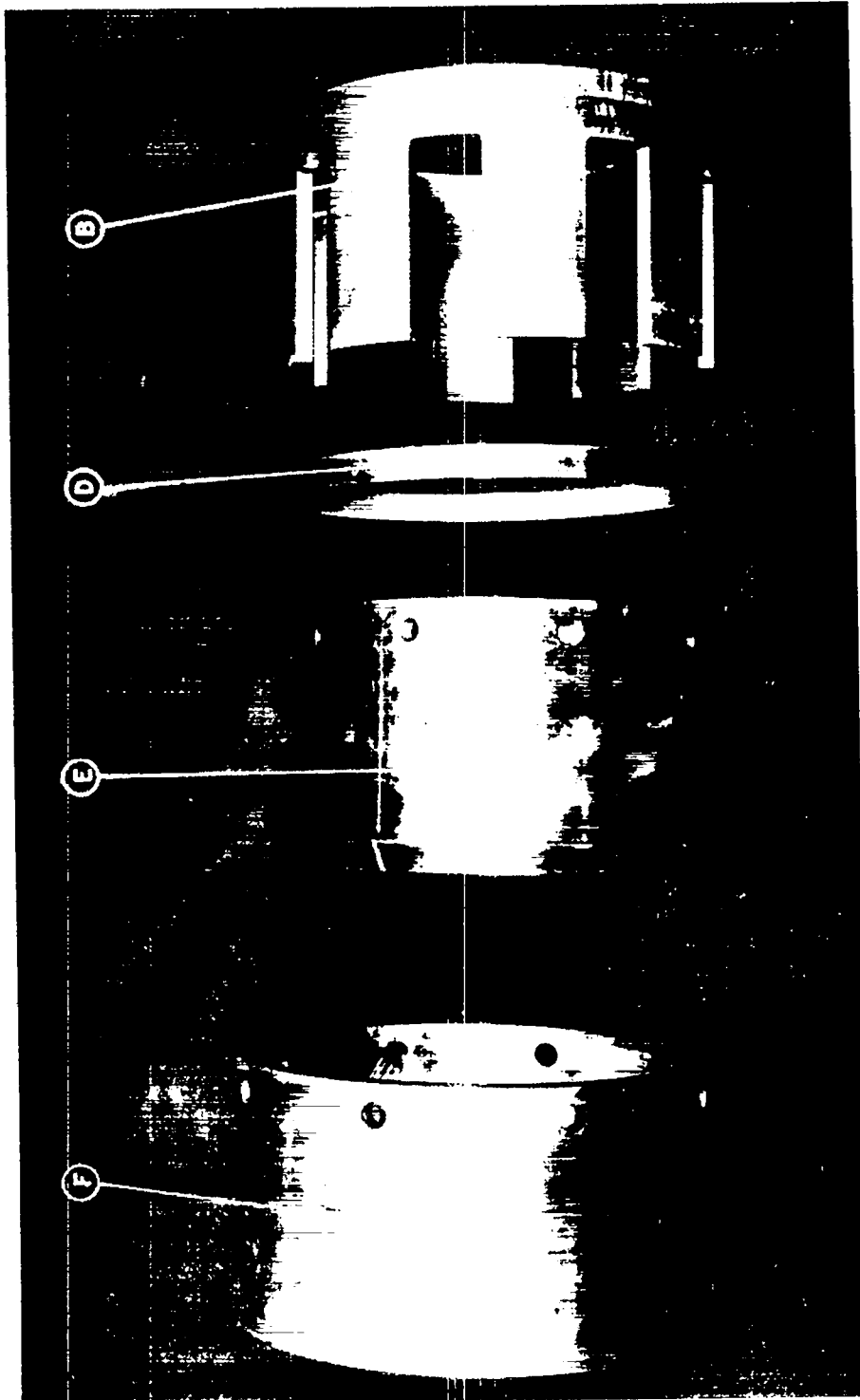

SECRET



Figure 11 - Photograph showing extrusion and ram
assembly in press prior to extruding.



000000
3100

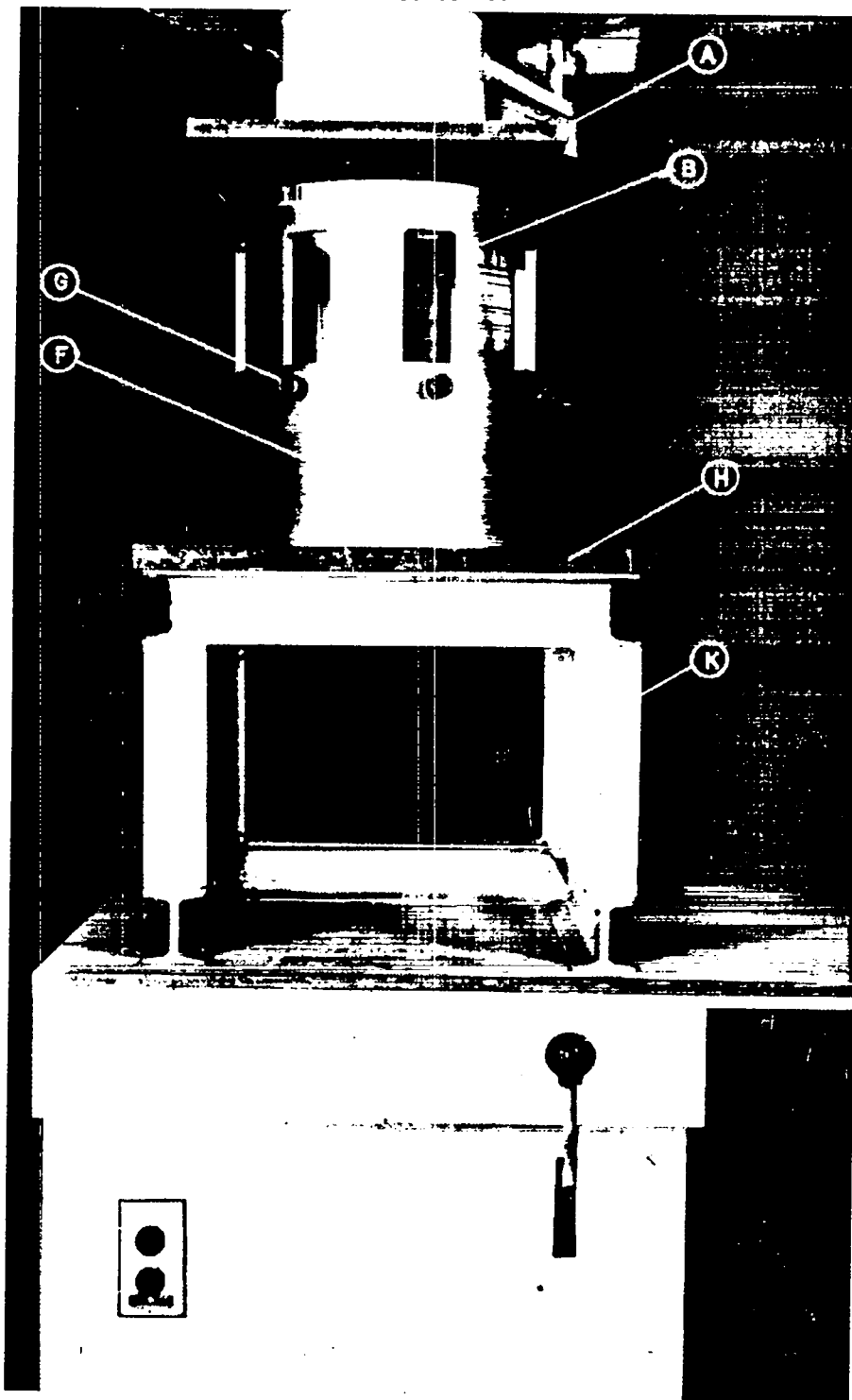

000000
3100

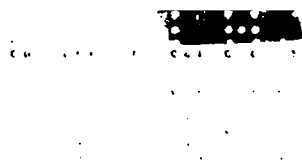

Figure 12 - Photograph of extruded cylinder 13.5
inches in O.D. by 0.100 inch wall.



SECRET



SECRET



Figure 13 - Photograph of liquid wax well (Figure 5-J).

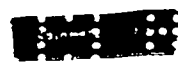

SECRET

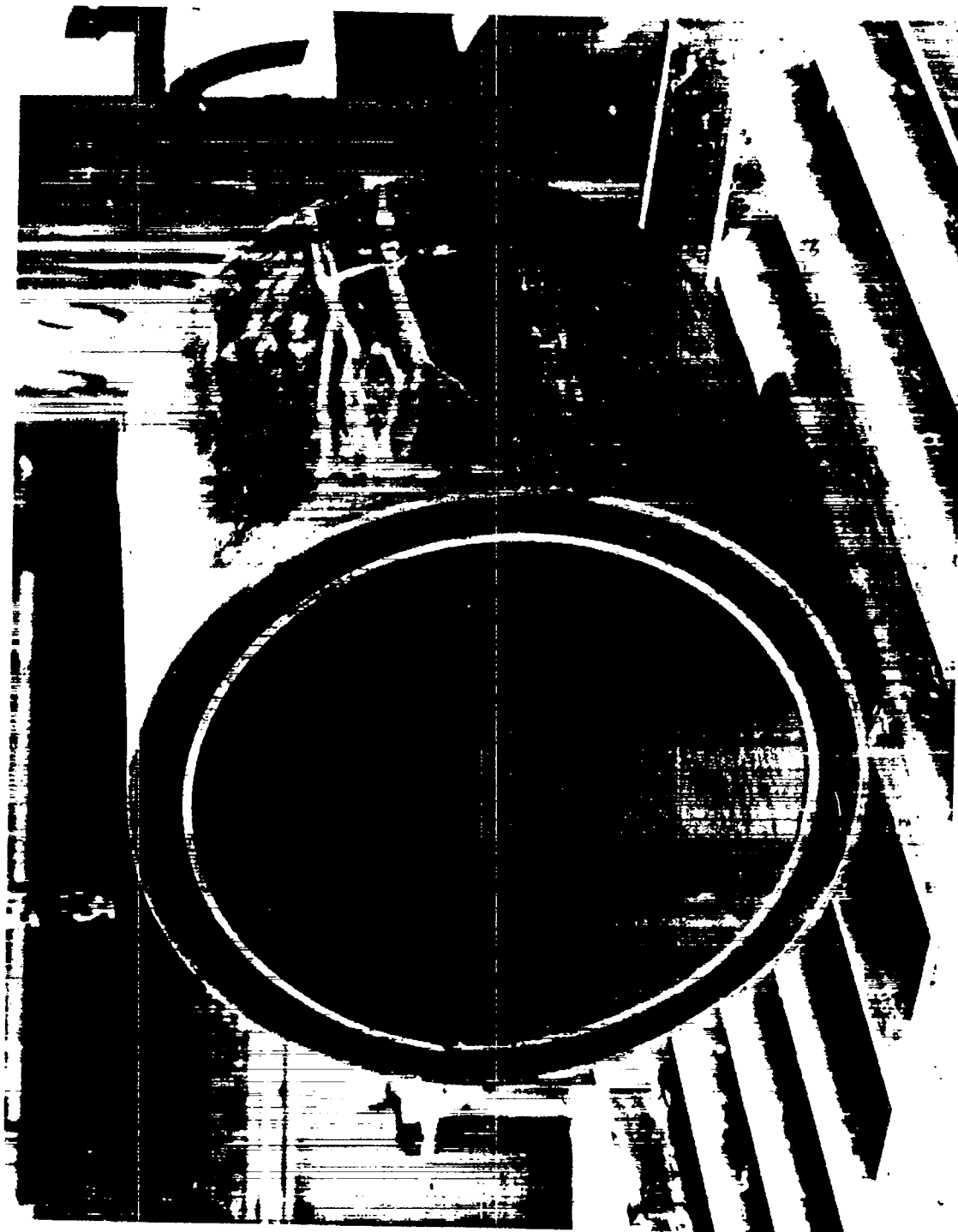

SECRET

CONFIDENTIAL

the metal space in the extrusion cylinder. Each end of the several lengths was cut on a 45° angle and assembled into one continuous ring. Before assembly, each end was thoroughly cleaned to remove surface oxidation and provide metal to metal contact. After extrusion, approximately fifty percent of the extruded length showed good pressure welding of the individual pieces. The first portion of the extrusion showed no bonding between the several sections. From the results obtained later in the welding of lithium, it is felt that the welding of rolled sheet into circular billets for extruding would be more advantageous than casting a ring.

Rolling

The rolling of lithium offered no particular difficulties. The use of kerosene as a surface coating is highly recommended as it affords the personnel working with the lithium both protection and safety (1). The rolls should be covered with sufficient kerosene so as to allow free passage of the lithium being rolled and to keep the lithium from sticking to the rolls. Heavy or light reductions can be made depending on the required thickness needed.

Welding

1. Spot welding.

A technique for spot welding lithium was used whereby copper sheet (0.020 inch thick) enclosed the lithium sheet (0.100 inch thick). The copper provided good thermal and electrical conductance

CONFIDENTIAL

 3110

and acted as a protection against the spattering of liquid lithium. Pictures were taken showing samples of spot welded strips, weld test and tensile spot-weld test and are shown in Figures 14 to 17. Spot welding was performed on a Taylor Winfield, type ERB-12-75 spot welder. Recommended settings using 0.006 inch copper sheeting as a covering are as follows:

DATA

Electrode Pressure	7 lbs.
Welding Force	3½ lbs.
No. 1 Transformer	high setting
No. 2 Transformer	low setting
squeeze time	3.75 sec.

2. Hot-Iron Welding.

Rolled sections of lithium approximately 3/8 inch in thickness were cut and welded together using a heavy solder iron at approximately 287°C. A stream of argon was directed on the freshly cut surface to minimize oxidation during the welding operation. Figure 17 shows samples of welded sections and Figure 18 a circular ring made by welding strip together.

Physical Tests

Test strips were cut from extruded sheet 0.100 inch in thickness and pull tests made, results of which are presented in the table below.

3110

SECRET
38

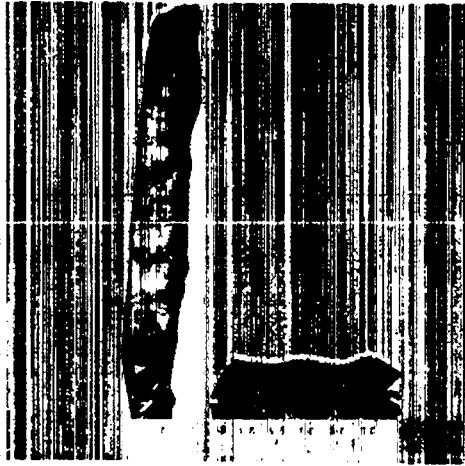

Fig. 14: Lithium sheet - 100 mil thick spot welded and tear test - half size.



Fig. 15: Enlargement of tear test as shown in Fig. 14 - 2 x.

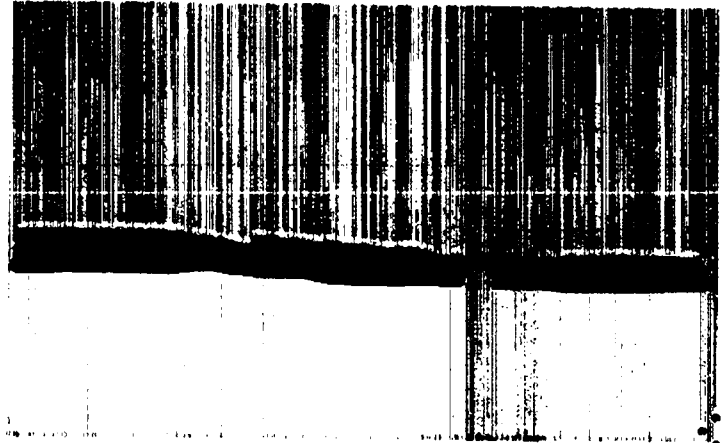

Fig. 16: Lithium test strip spot welded and pull test made showing good spot weld area.

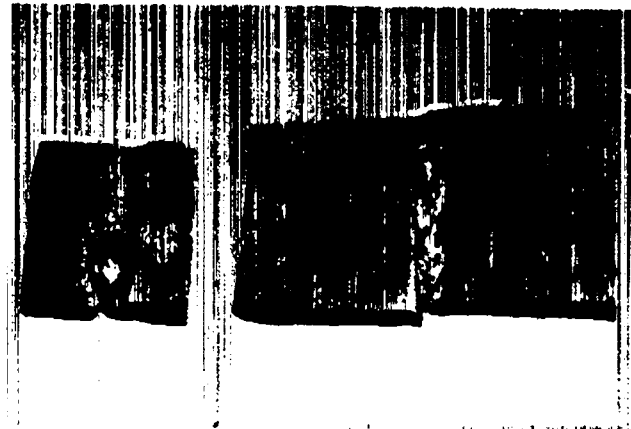

Fig. 17: Lithium sheet - 1/32" thick welded with heavy copper iron @ 287 C.

SECRET

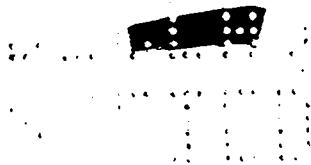
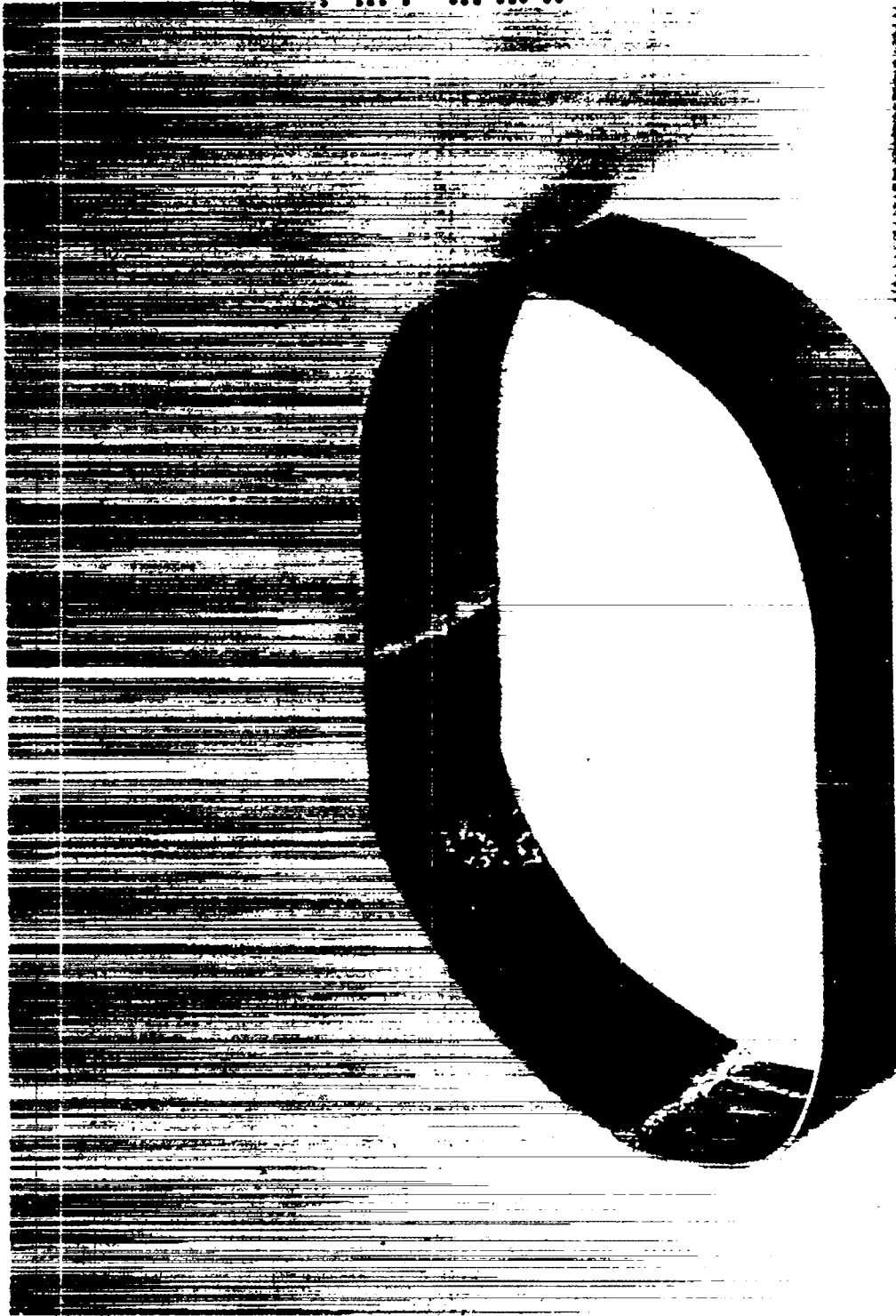

Figure 18 - Photograph showing circular ring of
lithium sheet formed by iron welding.



SECRET
SECRET



SECRET 40
SECRET

SECRET

TABLE I

Pull Tests on Lithium Sheet.

<u>Sample No.</u>	<u>Temperature of Test</u>	<u>Tensile Strength</u>	<u>Elong. 2" gage length</u>
1	(25°C) Room Temperature	150 psi	(a) 45.0%
2	" "	166 psi	(a) 58.0%
3	" "	185 psi	(a) 50.0%
4	" "	134 psi	(a) 50.0%
4	-116°C	225 psi	(c)
5	-113°C	227 psi	(c)
6	-200°C	555 psi	(b), (c)
7	-200°C	650 psi	(b), (c)
8	-200°C	760 psi	(b), (c)
9	-200°C	790 psi	(b), (c)

(a) Average values at RT (25°C), 159 lbs/sq.in., 50.7% elong.

(b) Average values at -200°C, 688 lbs/sq.in.

(c) Broke outside of gage length, no visible elongation.

The point at which elongation will start after the sample has been cooled down to sub zero temperatures is shown by the following experiment. A test strip (0.100 inch thick) was cooled down to minus 122°C and a weight equal to 310 psi was applied to the sample. No elongation was apparent. The sample was allowed to warm up slowly with temperature readings being taken continuously. At

SECRET

U. S. GOVERNMENT PRINTING OFFICE
 1964 O - 351 100

minus 50°C the sample began to elongate. Elongation continued until failure of the sample took place at 20°C. An elongation value of 35 percent was recorded.

Corrosion of Lithium and its Protection

This is covered in detail in the Appendix.

Safety and Handling Precautions

Procedures followed in the handling of lithium metal consisted of protective clothing, safety glasses, gloves and keeping the solid metal submerged in kerosene prior to working. Use of kerosene during rolling and extruding was mentioned earlier in the discussion.

Personnel working with lithium should prevent access of air to lithium on account of the formation of the black nitride which is believed to increase materially the viscosity of liquid lithium. In the case of fire, the fire may be smothered with dry sand or a mixture of dry sand and iron filings.

Conclusions

Results show that lithium metal can be readily fabricated by rolling, welding and extrusion. Necessary precautions must be maintained by the personnel in handling the metal at all times.

Recommendations

In the event that additional work is performed on lithium metal, the following procedures should be considered.

1. If it is required that the cylinder be extruded, direct casting into the die using a mold plug on the lower die orifice

U. S. GOVERNMENT PRINTING OFFICE
 1964 O - 351 100

SECRET

would eliminate casting a ring and the difficulties arising from removing the as-cast metal from a casting mold. Use of a paraffin vapor in the casting of liquid lithium would eliminate the formation of oxides.

2. Rolling lithium sheet to the desired thickness and length, and utilizing a welding technique to form a ring which can be extruded.

3. Eliminating extrusion altogether and forming the cylinder by joining rolled sheet either by spot welding or with iron welding.

SECRET

SECRET

APPENDIX I

Preliminary Report on the Corrosion of Lithium
and its Protection*

The protection of lithium from corrosion is normally carried out by immersing the lithium in kerosene; however, the application of lithium in the weapon program will not allow storage under kerosene. Therefore a coating of some sort, either metallic or non-metallic would be required.

The actual conditions to which the finished lithium shape would be exposed has not been definitely set. This leaves the range for testing wide open as far as temperature and humidity are concerned.

Preliminary investigations show that lithium can not be plated directly in an aqueous solution since lithium reacts very readily with water. Hopkins (1) has a vague reference to the protection of lithium by electroplating. The reference could not be found.

The use of non-aqueous plating media suggested a possible substitute bath for plating on lithium, however, a large number of organic baths contain water and the remaining organic baths (no water) which were investigated reacted with the lithium.

*This work was done by the Electrochemistry Section of Group CMR-6, J. Gore, Section Leader, R. Seegmiller, A. Fox and A. Pinkerton.

SECRET

SECRET

Attempts to coat the lithium samples with a thin film which would make a water tight envelope around the sample were tried.

Figure 19 shows the corrosion results of these various coats when tested at 22°C and 20% relative humidity. The samples which were painted with (1) silver conducting paint, and (2) plastic spray, corroded at a faster rate than bare lithium. Two samples which were painted with commercial semi-gloss blue paint and aluminum paint corroded at a lesser rate than bare lithium.

In the interpretation of corrosion data, the work of McKay (2) has been used as a standard. A corrosion rate of 10 mdd. (10 milligrams weight gain per square decimeter per day) has been chosen as the failure limit. The curves of Figure 19 give a corrosion rate greater than 600 mdd. which represent excessive corrosion.

The Plastics Section was asked to coat a sample of lithium with any organic material. Several samples were submitted to this section for corrosion testing.

The lithium was dip coated with a paraffin base mixture 10% Alathon "E", 90% Paraffin, developed by the Plastic Section of CMR-6 and discussed in Appendix II of this report.

The curves as shown in Figures 20 and 21 give the rate of corrosion at 22°C and 20% relative humidity. Each curve shows a loss in weight in the first ten days which may possibly be attributed to the release of absorbed moisture in the paraffin. Although there is a ten fold difference in area between samples the slopes of the two

SECRET

SECRET

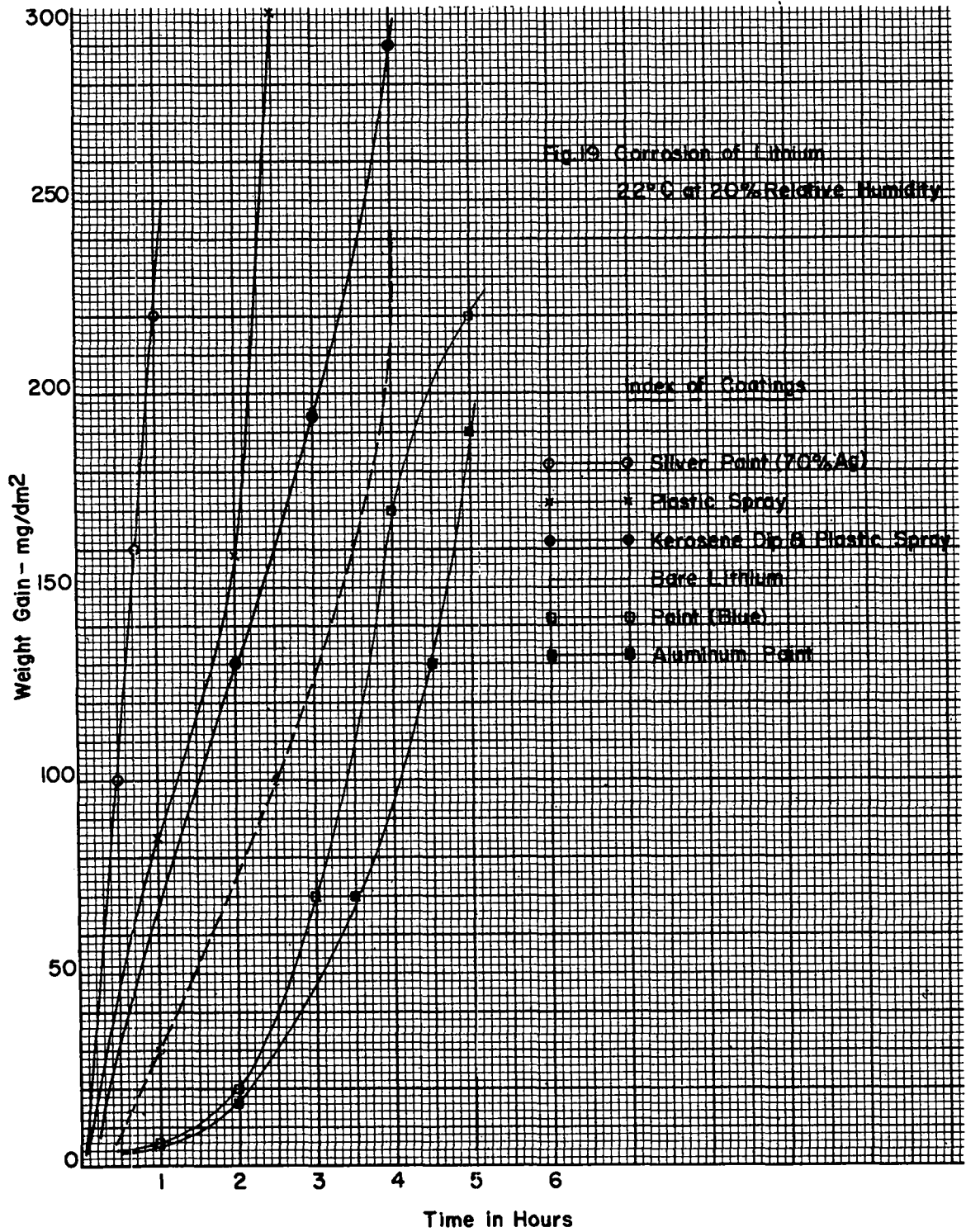

SECRET

SECRET

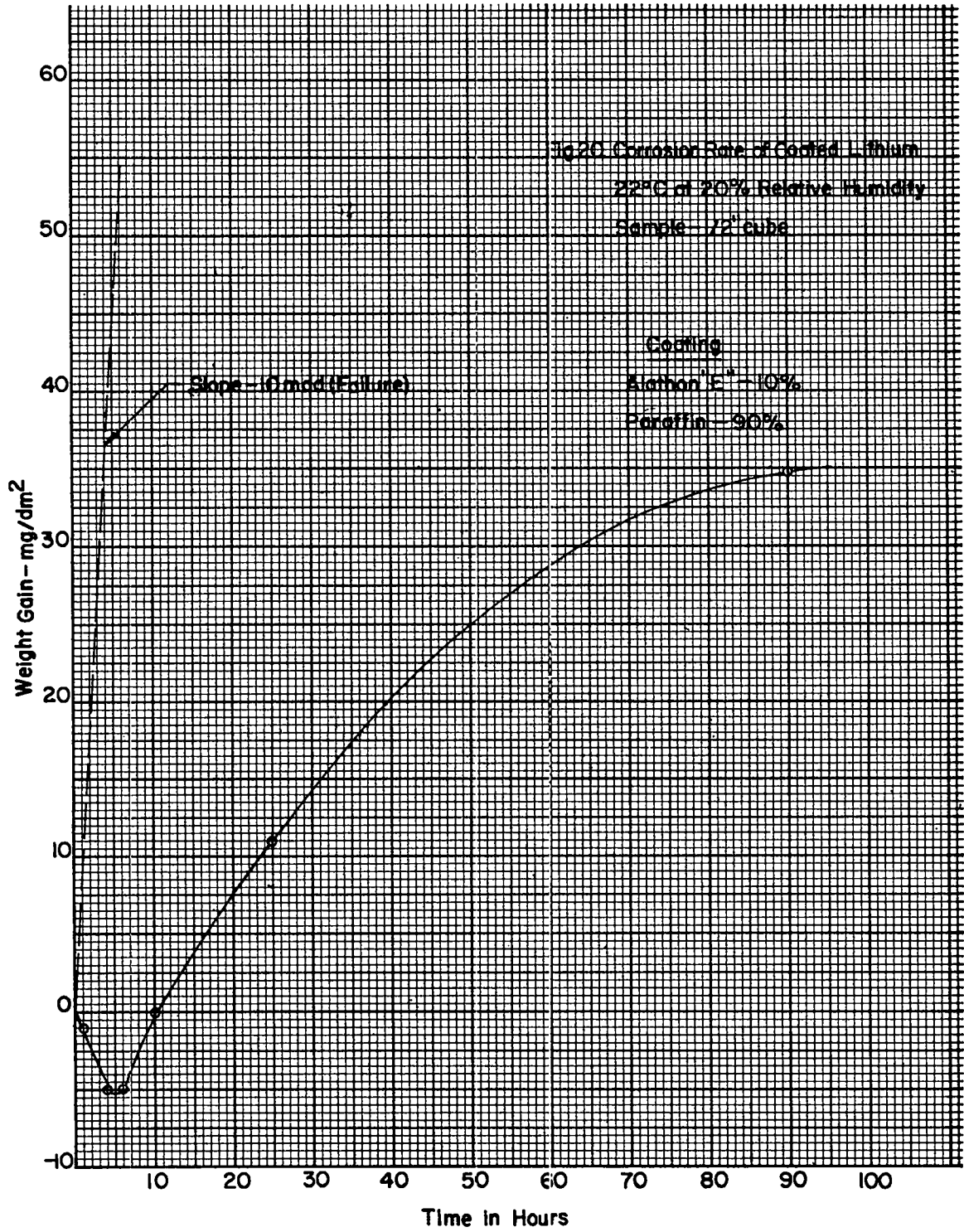

SECRET

SECRET

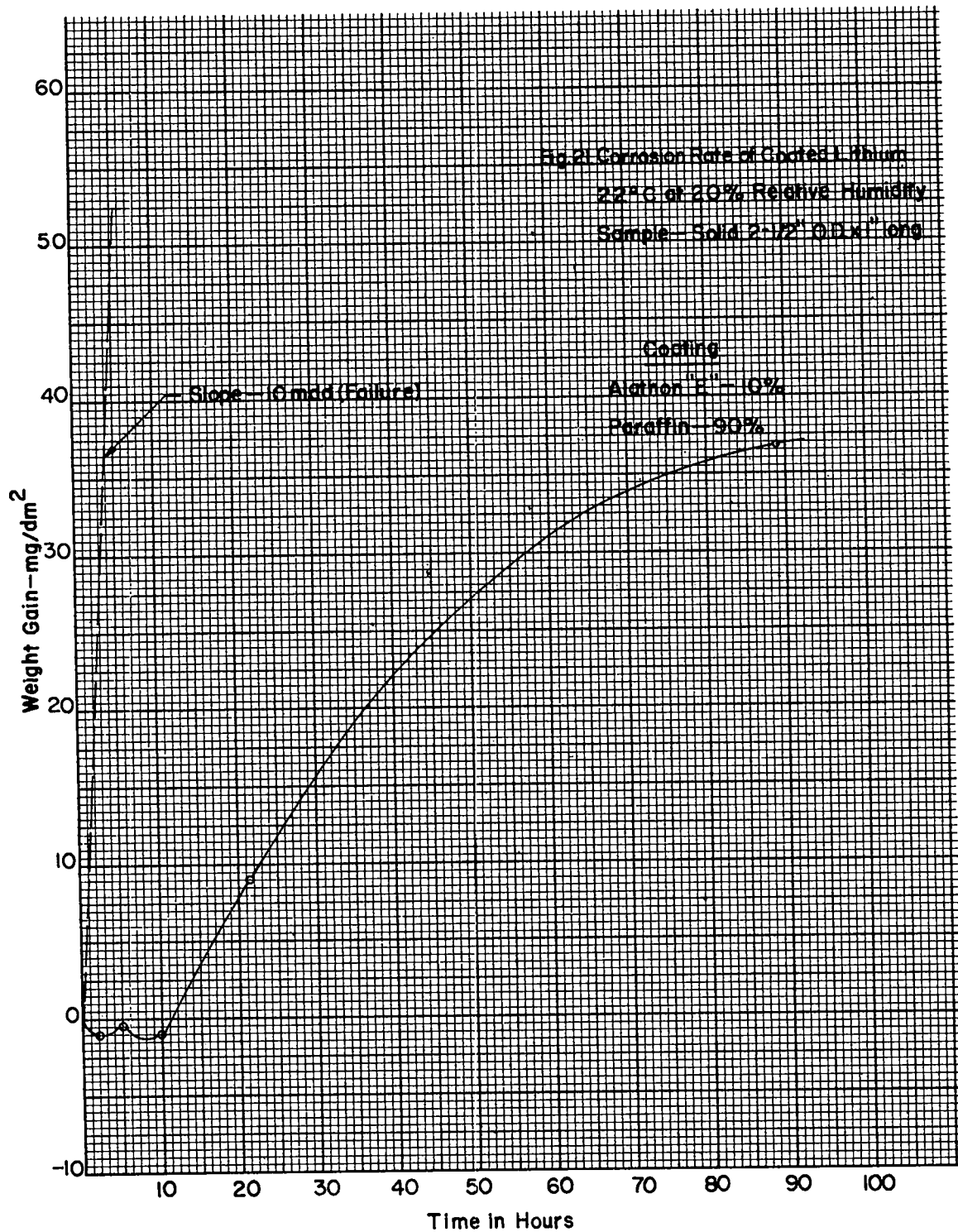

SECRET

 3119

curves are relatively the same. The paraffin base coated lithium is well within corrosion limits over a 90 day period (less than 1 m.d.). Thus, if the fabricated lithium pieces were dip coated using the 10% Alathon "E" - 90% Paraffin mixture and stored under conditions of 22°C and 20% relative humidity; the corrosion rate would be negligible for at least a 90 day period.

Samples of bare lithium ($\frac{1}{8}$ " dia. x 1") were corrosion tested under the following conditions.

	<u>Temp.</u>	<u>Relative Humidity</u>	<u>Time</u>	<u>Weight gain</u>
A.	20°C	35%	108 min.	368 mg/dm ²
B.	20°C	65%	139 min.	146 mg/dm ²
C.	20°C	95%	101 min.	109 mg/dm ²
D.	40°C	35%	140 min.	142 mg/dm ²
E.	40°C	55%	138 min.	276 mg/dm ²
F.	40°C	75%	140 min.	281 mg/dm ²
G.	60°C	30%	141 min.	762 mg/dm ²
H.	60°C	75%	122 min.	1660 mg/dm ²
I.	80°C	30%	157 min.	2310 mg/dm ²

Sample A increased almost linearly during test time.

Samples B and C increased linearly for half test time and then dropped off to (B) 110 mg/dm² at 110 min., (C) 30 mg/dm² at 65 minutes; then both samples increased as shown above. Samples D, E, and F showed the same characteristics as Sample B and C except at a higher

3119

SECRET
 FILED

corrosion level.

Samples G, H, I showed a near linear increase over test time.

These preliminary tests show that there is a possible corrosion protection from an early formation of the nitride-oxide layer; however, the corrosion rates are above the failure limit.

Work has been started duplicating the same conditions as A thru I. Samples were coated using the 90% Paraffin - 10% Alathon "E" mixture. Tests at 60°C and above were cancelled due to the wax mixture reaching a plastic flow under these conditions. There are no results to be reported at this time on the remaining samples.

The Fabrication Section submitted a small cylindrical sample of extruded lithium which had been wax coated for corrosion protection. The corrosion data followed the same pattern as reported in Figures 20 and 21. As the area of the so-called cylindrical shape could not be calculated, no curves are submitted.

Figure 22 shows the corrosion rate of a lithium alloy (10 atomic percent Magnesium) as compared to corrosion rate of bare lithium at 22°C and 20 percent relative humidity. The presence of magnesium retards the rate of corrosion, however, 10 percent (atomic) addition does not bring the rate within the 10 mdd. limit. There were no investigations made to study alloys containing a higher Magnesium content.

SECRET
 FILED

SECRET

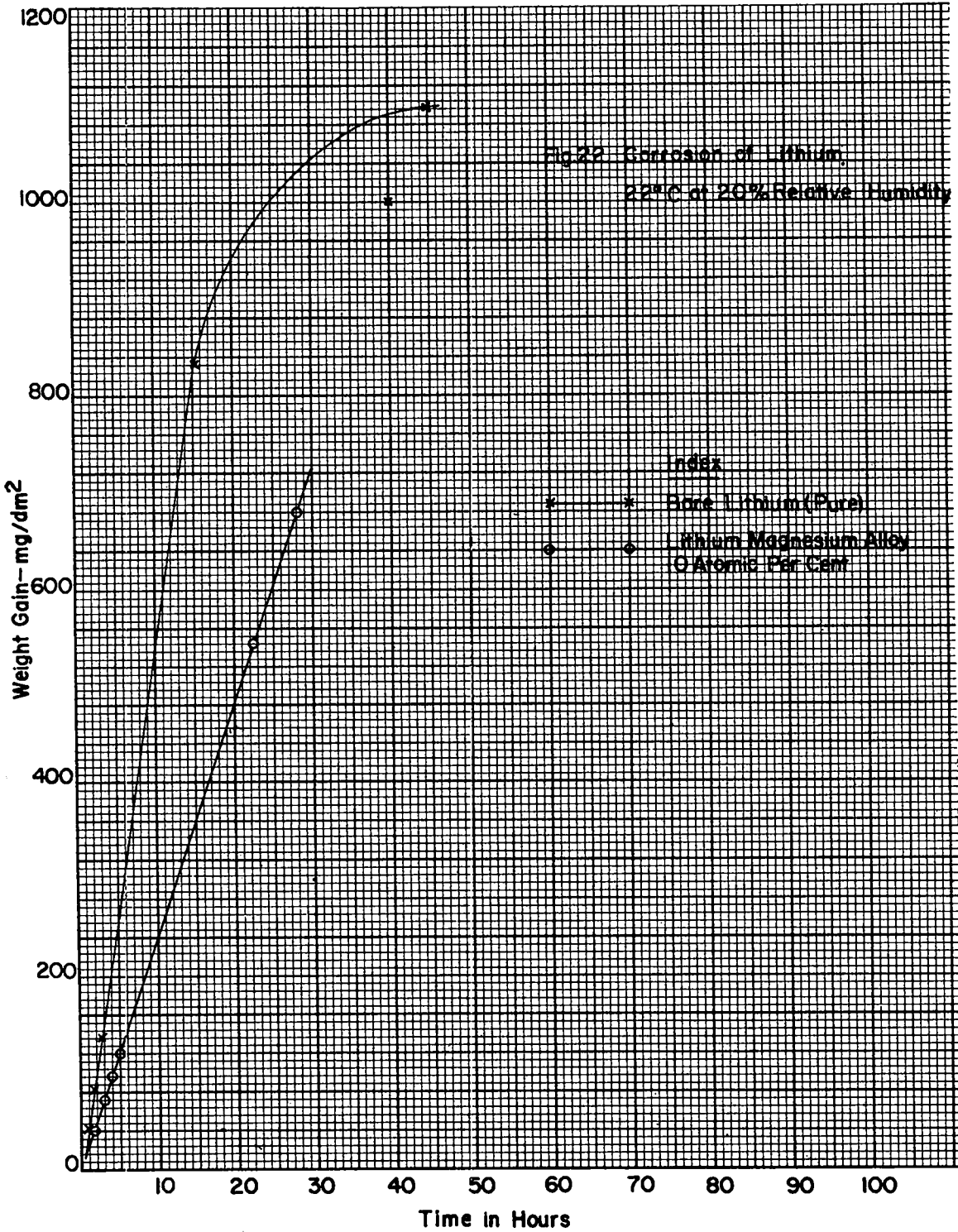

SECRET

CONFIDENTIAL

APPENDIX II

Lithium Corrosion Protection*

1. Introduction

The problem as originally received by the CMR-6 Plastics Section from James Gore and G. S. Hanks, CMR-6 Electrochemistry and Fabrication Sections, was to provide an easily applicable plastic coating which would provide effective corrosion protection for lithium, both from air nitriding and oxidation as well as from moisture. Later the Plastics Section was asked to develop a coating that would provide the necessary corrosion protection and also withstand simple forming procedures, such as rolling, without failure.

The first step in the solution of this problem was, naturally, the selection of materials. There were several limiting factors, such as moisture permeability, permeability to oxygen or nitrogen, melt viscosity, temperature of application, solvents necessary for application, and presence of easily available halogens, nitrogen, hydroxyl groups, etc., in either solvent or coating resins. Consideration of these factors, and the study of the small amount of literature available, lead to the evaluation of solutions and melts of materials such as the vinyls, polyethylene**, paraffins, polybutene

* This work was done by the Plastic Section of CMR-6 by G. S. Price under J. S. Church, Section Leader.

** $(-\text{CH}_2-\text{CH}_2-)_n$

CONFIDENTIAL

SECRET
 5110

or mixtures of one or more of these. All of these materials had desirable characteristics, but no one had all the necessary qualities.

Prospective methods of application were also considered in choice of materials. Obviously, any material requiring prolonged cure at elevated temperatures would not be suitable, nor would application of a coating by the use of slow drying solvents. Application by dipping or brushing of a hot melt composition, and spraying or painting with a fast drying solvent vehicle were alternative solutions to the problem. The latter methods lent themselves to the vinyls, while the former were suitable for polythene or paraffin.

II. Experimental Formulations

Early attempts at corrosion protection were made using standard stock solutions. The first was a solution of 100 gm. "heavy" polybutene/2000 cc toluene, and the second was a mixture of the following composition: VYNS No. 448 (vinyl chloride-acetate copolymer) 18%, Methyl Ethyl Ketone (solvent) 72%, Flexol DOP (dioctyl phthalate plasticizer) 10%. Each of these solutions was applied to 1/2" Li cubes by dipping. The polybutene-dipped cube nitrided immediately and the VYNS-coated cube failed due to reaction between the Li and the coat, probably halogenation as was previously suggested. A third attempt was made using a hot-melt mix:

Blend A

Component	parts by weight
Alathon E	1
Paraffin wax	9

SECRET
 53
 SECRET

SECRET

The Alathon E is a low molecular weight polythene. A 1/2" cube was dipped at 83°C, allowed to cool and dipped again. Two test pieces prepared by this method were submitted to CMR-6 Electrochemistry Section. Test results showed a definite decrease in corrosion rate over that for uncoated Li cubes.

The next stage of the problem was to provide a coating that would not fail during rolling or other simple forming processes. The first mix, or blend, contained:

Blend B

Component	parts in weight
Alathon B	1
Paraffin wax	2

The Alathon B is a higher molecular weight polythene than the "E" grade. By virtue of this fact it also has greater elongation, less brittleness, and a higher melt viscosity at any given temperature. This mix was more difficult to apply and failed on the first pass through cold rolls. It was decided to plasticize the mix with polybutene*, a commercial elastomer that is compatible with polythene. The following mix: 50% paraffin, 25% polythene, 25% polybutene, was too viscous to apply at 150°C which was considered to be a maximum working temperature in view of the melting point of lithium.

* $-\text{C}(\text{CH}_3)_2-\text{CH}_2-$ N

SECRET

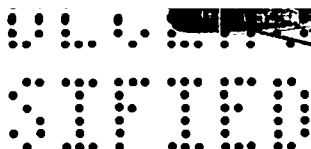

 SIFTED

UNCLASSIFIED

The next mix was:

Blend C

Component	parts by weight
Alathon C	1
Polybutene	1
Paraffin wax	4

Alathon C is intermediate between the "B" and "E" grades. This mixture was applied at 150°C and given about 10 passes through cold rolls before failure. About 50% reduction in thickness was obtained which was deemed sufficient. Later it was found necessary to change the composition since a new lot of polybutene apparently had a greater molecular weight, though the manufacturer's designation was identical with that of the first lot. The final and optimum mix is as follows:

Blend D

Component	parts by weight
Alathon C	2
Vistanex B-80	1
Paraffin wax	8

As stated above the Alathon "C" is polythene with an average molecular weight of 12-13,000, and the Vistanex is polybutene with an average molecular weight of 80,000; the paraffin is 56°C melting point grade.

If it is not necessary to have a coating which will withstand forming procedures, it would be well to use Blend A which contains no polybutene as it gives a more uniform coat that is easier to apply. The polybutene apparently adds nothing to the corrosion protection

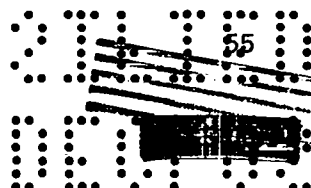

 55

UNCLASSIFIED

~~SECRET~~

qualities, though it does effect a reduction in brittleness.

III. Recommended Procedure

The preferred laboratory procedure as developed in the Plastics Section is outlined in the following paragraphs:

There are three general stages encountered: (a) preparation of the melt, (b) preparation of shape to be dipped, and (c) dipping.

(a) The preparation of the melt is fairly simple. The only precaution to be taken is to minimize the fire hazards involved in processing hot paraffin. The wax is completely melted at 80°C; to this is added the polythene with stirring. The polythene should be in the form of 1/8" pellets, or smaller. The temperature is now raised to 180°C - 200°C, and the polybutene is added, also in the form of 1/8" pellets. The mix is held at 180°C and stirred for about 18 hours. The time required for complete solution is determined primarily by batch size.

As soon as the mix appears homogeneous it should be poured into a shallow tray and cooled rapidly to prevent separation of the components. It is then cut into 3" squares to facilitate melting when needed.

(b) The only critical phase of the preparation of the Li shape for dipping is the removal of kerosene which happens to be a solvent for the paraffin component of the mix. It is well, of course, to remove any surface coating of oxide or nitride from the surface of the lithium if a bright piece is desired. This was done, incidentally, on the small pieces which were intended for corrosion testing.

~~SECRET~~

UNCLASSIFIED

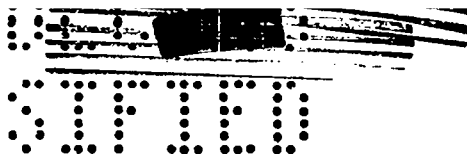

UNCLASSIFIED

(c) Following surface preparation, if any, the piece is immersed in the melt which should be maintained at 150-160°C for best results. After about twenty seconds of total immersion, the piece can be removed and air cooled for thirty minutes. It is sometimes necessary to retouch the coating where bubbles have formed and where tongs have covered the shape. It was found that a period of forced cooling in a refrigerator holds bubbling to a minimum. This technique produces a coat approximately 1/16" thick. The mix can also be applied by brush, but this is not too satisfactory a method as the coat is not uniform. The brush tends to foul quite rapidly as the blend freezes on it which makes preparation of a smooth coat increasingly difficult.

The final technique as used on a large thin-wall cylinder, extruded by CMR-6 Fabrication Section, was as follows:

No surface preparation was done since the lithium was freshly extruded. The extrusion was taken from the die immediately and immersed totally in the tank of mix held at 150°C. After about 20 seconds it was removed, allowed to drain and harden slightly, then placed in a refrigerator at 5°C for about thirty minutes. It was found necessary to brush coat a few places where the coating was dangerously thin, especially over sharp corners, protrusions and the like.

IV. Evaluation

The corrosion testing done on these hot-melt coatings is being reported in full by CMR-6, Electrochemistry. It is well to

57

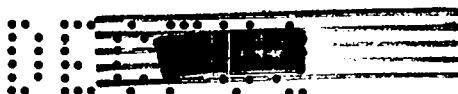

UNCLASSIFIED

UNCLASSIFIED

SECRET

note, however, that no appreciable corrosion occurred at standard conditions, but that the "failure" temperature as found by Gore was 60°C at 30% relative humidity. The rolling test was previously reported, failure occurring at 10 passes using cold rolls. When the rolls were heated to 50°C, only two passes were possible since the coating started to adhere to the rolls. This was the extent of the testing program.

V. Conclusions

In general the quality of the coatings was good, in some cases bubbling was severe, especially where there was residual kerosene. This was alleviated greatly by the more rapid refrigerator cooling. The coating itself was tough and could be handled with very little care when thoroughly hardened.

Nearly any regular surface lends itself to dipping applications, some difficulty is encountered, however, where there are sharp points or small protrusions since the melt tends to run off before it is hard. This, of course, leaves a thin coating. 1/2" cubes, 1/2" x 1/2" rods, 1-1/2" x 1/8" x 6" bars and a cylinder 13" diameter x 12" long with 1/10" wall were the only shapes encountered at this time, but no limitations should be met with other regular geometries.

The quality of the coating could be improved greatly by utilization of a completely automatic dipping system which, of course, was not feasible at this time due to the scale of the work. An automatic process would eliminate the need for redipping and would

SECRET

UNCLASSIFIED

SECRET

allow more accurate control of the coating thickness. More rapid cooling would also be advantageous in that the formation of pin holes due to bubbling would be minimized.

If more strenuous forming procedures are to be used, the plasticizer content could be increased slightly. However, from the results obtained with the 25% polybutene mix, which was too viscous to apply at 150°C, a better approach would be through the use of a less viscous elastomer such as a lower molecular weight grade of polybutene. If the emphasis is on the thermal stability of the coating, an increase in polythene content would be advisable; or, for the same effect, a reduction in paraffin content. An increased polythene content, on the other hand, would make a more viscous melt and one which would be more difficult to apply at a reasonable working temperature.

Bibliography

- (1) Chapters in the "Chemistry of the Less Familiar Elements", by B. Smith Hopkins, Vol. I, published by Stipes Publishing Co.
- (2) "Corrosion Resistance of Metals and Alloys", McKay & Worthington, Vol. 71, pages 102,103.
- (3) Materials Handbook - by George S. Brady, McGraw-Hill, pages 350-351.
- (4) Liquid Metals Handbook, published by A2C Dept. of Navy, Washington, D. C., pages 60-61.
- (5) Metals Handbook - 1948 Edition - American Society for Metals.

SECRET

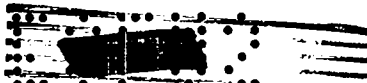

UNCLASSIFIED

040000
03712

DOCUMENT ROOM

REC. FROM YA

DATE 4-20-57

REC. NO. REC. ✓

040000
03712