

This report was prepared as an account of work sponsored by the United States Government. Neither the United States nor the United States Atomic Energy Commission, nor any of their employees, nor any of their contractors, subcontractors, or their employees, makes any warranty, express or implied, or assumes any legal liability or responsibility for the accuracy, completeness or usefulness of any information, apparatus, product or process disclosed, or represents that its use would not infringe privately owned rights.

15D-6
 007-740402--16

A CONCEPTUAL LASER CONTROLLED THERMONUCLEAR REACTOR POWER PLANT*

J. Williams, T. Merson, F. Finch, F. Schilling, and T. Frank

University of California
 Los Alamos Scientific Laboratory
 Los Alamos, New Mexico

ABSTRACT

MASTI

The design of a conceptual 1000 MWe laser-fusion power plant is presented. Twenty-four reactor cavities, based on the wetted-wall concept, are included in this facility. Fusion pellets producing 100 MJ of thermonuclear energy release per microexplosion are ignited by 1-MJ laser pulses at the rate of 1.2 per second in each of the reactor cavities. Laser pulses are provided by a central laser system which serves all reactor cavities and which is based on short-pulse CO₂ laser technology.

Important considerations which led to design choices included component reliability, redundancy of essential components, access to components for service and/or replacement, and minimization of hazards from radioactive materials.

I. INTRODUCTION

The rapid development of laser fusion technology, together with the urgency for providing sources of safe, clean, low-cost electrical energy have prompted consideration of engineering required for fusion reactor power systems. [1,2,3] A conceptual design of a central station power plant for the production of a nominal 1000 MWe of electrical energy has been prepared. The purpose of this conceptual design study is to assess some of the engineering problems which must be faced in an integrated plant design with compatible subsystem interfaces between complex components such as lasers, optics, reactor cavities, and energy conversion systems, plus design compromises within the conflicting constraints of high performance, low environmental hazard and the cost of high-technology components. Although still highly conceptual in nature, these design studies have been useful in understanding potential engineering requirements.

II. PLANT DESCRIPTION AND MAJOR DESIGN FEATURES

The conceptual 1000 MWe LCTR power plant has the characteristics shown in Table I. Pellets producing 100 MJ of thermonuclear energy per microexplosion are ignited by 1-MJ, subnanosecond laser pulses occurring at 1.2 pulses per second for each of 24 reactor cavities. An energy multiplication factor of 1.3 in the lithium blanket and reactor structure leads to a thermal power per reactor cavity of 156 MWt for a total of 3745 MWt for the whole plant.** Assuming 7% laser efficiency, 93% beam transport efficiency, 40% thermal to electrical conversion efficiency and a net laser light on target to thermonuclear energy production

*Work performed under the auspices of the US Atomic Energy Commission, Contract Number W-7405-ENG-36.

**Calculations of energy deposition utilized kerma factors from Ref. 4. More recent data (Ref. 5) are apparently more consistent, i.e., with respect to energy conservation, and will be used in the next iteration of systems studies.

BLANK PAGE

gain of 100, the circulating power is 33%. Of the total 1500 MWe produced from the total thermal power of 3745 MWt, approximately 500 MWe is required to drive the lasers leaving a net electrical power of 1000 MWe. Thus, the net overall plant efficiency is 27%.

Lasers and reactor cavities are arranged in a circular array around a central optical switching device to provide for optimum use of the lasers. Maximum pellet energy release of the order of 100 MJ and limitations on the maximum pulse rate per cavity necessitate the modular arrangement of multiple reactor chambers to achieve total power outputs of 1000 MWe. This, however, has advantages as discussed later.

This version of an LCTR power-plant concept includes 16 separate laser amplifiers, 24 reactor cavities with associated beam-transport systems, and 12 pairs of primary lithium-sodium and sodium-steam heat exchangers. A lithium-processing and tritium-removal system is associated with each lithium-sodium heat exchanger. Each set of heat exchangers and associated lithium processing equipment serves two reactor cavities.

III. LASERS AND POWER STORAGE

Because of its potential low cost and high operating efficiency, an electron-beam sustained-discharge CO₂ laser has been postulated for the conceptual plant. The annular power amplifier design is shown schematically in Figs. 1 and 2. Eight of these laser amplifiers provide the required 1 MJ per pulse of laser energy. A total of 16 laser amplifiers provide a redundant partner as a ready back-up for each operating laser. Each annular lasing cavity is subdivided into eight subcavities which can be pulsed simultaneously or individually in a programmed manner. Sequential pulsing of individual subcavities may provide some capability for pulse-shaping by superimposing beams. Annular pulses are collected and focused by means of a toroidal, catoptric beam-focusing device. At 29 pulses per second, circulation of laser gas for convective cooling is required. Assuming a permissible gas temperature rise of ~ 125 K, a gas flow rate of ~ 400 m³/s is required to provide 52 MW of cooling capacity for each annular laser amplifier, giving a total of 413 MW of thermal energy from the lasers. Pumping power for the laser cooling loops is about 40 MW, and other auxiliary power requirements are about 10 MW.

Because the lasers and laser energy storage subsystems represent a significant fraction of the capital investment in an LCTR plant, it is economically advantageous for them to be centralized where they may serve a number of reactor cavities. However, a centralized laser system requires rapid beam-switching from laser power amplifiers to selected beam ports. This beam-switching might be accomplished by a large rotating mirror such as shown in Fig. 3. The scheme requires moving the optics in a vacuum system with associated requirements for bearings and seals, very long light pipes, precise alignment of optical components and consideration of effects such as temperature changes, earth tremors, and plant vibrations. Biological shielding, to prevent radiation streaming through the laser beam-transport system, must be provided. It is believed that there will be economic advantages in this scheme, plus the advantage that the lasers are well-shielded from the reactor cavities.

IV. BEAM TRANSPORT AND OPTICAL SWITCHING

The conceptual beam-switching subsystem is shown in Fig. 3a. The laser beams from 8 of the 16 laser power amplifiers are reflected to mirrors mounted on a rotating assembly that successively directs the beams into the beam-transport tubes for each reactor cavity. The rotating mirror assembly has a rotational velocity of 1.2 revolutions per second, and the laser system has a pulse repetition rate of 29 pulses per second. Each individual mirror of the rotating assembly is controlled to aim the beam at the appropriate beam tube. Shown in Fig. 3b is the arrangement to allow the choice of either of two laser power amplifiers to provide each of the eight beams required for each pulse by switching a selector mirror.

Since the length of a 0.5 nanosecond light pulse is ~ 15 cm, it can be seen that either all optical path lengths from the laser to the pellet must be the same to within a fraction of a centimeter or the oscillator pulse for each laser amplifier must be carefully timed and controlled. The direct beam-transport path lengths between the beam-switching subsystem and a reactor cavity differ by a few meters, which would lead to differences in arrival times of laser beams incident on a pellet of the order of 10^{-8} s or ten times the pulse width. This may be compensated for by varying the position of the selector mirrors, Fig. 3b, so that all path lengths are the same, or by varying the arrival time of the incoming preamplifier pulse, Fig. 2.

Shielding of the laser system from neutrons and γ rays originating in the reactor cavity enclosures is provided by thick concrete walls and catroptic optics which provide an indirect laser-beam path through the wall as illustrated in Fig. 4. A beam expander is necessary at this point to maintain beam intensity below the damage threshold for a window which is located in the beam following the beam expander. The beam expander includes neutron shielding as well.

The eight laser beams illuminate the target pellet quasi-symmetrically in a pattern which does not have any two beams directly opposing. A possible layout of the beam tubes at the reactor cavity is shown in Fig. 5.

V. FUEL INJECTION

A fuel-pellet injection system is mounted on each reactor cavity. A conceptual fuel pellet injection system is shown in Fig. 6. Liquid helium is utilized to freeze a DT mixture which is extruded and cut to size by a laser cutting and shaping pulse. The pellet is then pneumatically or electrostatically accelerated through a rotating blow-back protection valve which operates synchronously with pellet injection so that the pellet passes through the bore, but the injection device is never directly exposed to x rays or pellet debris. Each cavity will require 37.8×10^6 pellets per year at 100% load factor.

VI. REACTOR CAVITIES, BLANKETS AND COOLANT

Various containment concepts have been proposed which are compatible with the general concept of a centralized laser and energy storage system. Among them are the wetted wall concept, [2] magnetically protected wall concept, [6] SATURN concept, [3] and the BLASCON. [7] For purposes of this study, we have chosen the wetted wall concept. The major consideration is that, unless very high pulse repetition rates are achievable in each cavity (10-100 pps), significant power levels appear very difficult to achieve economically by other than this modular reactor cavity approach.

VII. ENERGY CONVERSION

Energy released during the pellet burn is expected to consist of 1% in x rays, 7% in 2 MeV α particles, 15% in plasma kinetic energy, and 77% in 14 MeV neutrons. [1] In the wetted wall concept, [2] the x-ray, α , and debris energy is removed by ablation of liquid lithium from the cavity walls and subsequent blowdown and energy recovery in a supersonic spray condenser. The neutron energy is converted to heat in a liquid lithium blanket. Heated lithium is pumped from the blanket and the spray condenser to a Li/Na heat exchanger. The sodium loop is used to generate steam. Liquid metal loops and associated pumps and heat exchangers are located in the shielded reactor building. Each liquid metal loop serves two adjacent reactor cavities and is accessible by the overhead maintenance system by which components can be removed to hot-cell areas. Liquid metal loops operating at low pressure which allow the use of free surface pumps to handle the lithium flow of 137 kg s^{-1} from each reactor. With the high overall heat transfer coefficients attainable in liquid metal systems, the Li/Na heat exchangers are small (less than 3 m diam x 10 m long). Steam generators will borrow technology from the LMFBR program as it develops. Steam leaves the reactor building and is manifolded to the conventional turbine plant. Waste heat will be dissipated via natural draft cooling towers of conventional design.

FOR THE PRESENT PLANT DESIGN OF DISSEMINATING 2700 MW, IT IS EXPECTED THAT 3 LOWERS
in the 90 m diam x 120 m high class will be required.

VIII. FACILITY DESIGN AND LAYOUT

The layout of major plant components is shown in Figs. 7 and 8. Figure 9 is an artist's conception showing all major plant features.

Mechanical and structural isolation is provided for each laser system, radioactive cavity and associated beam-transport and heat-transfer system, component-servicing facilities, and operational and control areas. It is essential that vibrational disturbances to the optical and laser systems be minimized; thus, laser systems, including power supplies, oscillators, power amplifiers, and waste-heat removal systems, are located in a mechanically isolated, centralized building which is anchored to bed rock. Reactor cavities are located in a separate, annular building surrounding the laser-system building. Each reactor cavity is in a separate shielded enclosure with penetrations for laser beams, liquid-metal coolant, and the introduction of fuel. Heat is extracted from reactor cavities by flowing liquid lithium, is transferred to a sodium loop, and finally to steam generators. The heat exchangers and lithium-processing equipment for each pair of reactor cavities are located in a shielded enclosure adjacent to the cavity enclosures. Components containing tritium are designed to minimize component sizes and piping lengths. Control rooms and other work areas are isolated from the reactor radioactive areas.

Overhead cranes are provided for removal and replacement of the laser power supplies. The laser power amplifiers and optical systems are accessible through the main access corridor. Reactor cavities and cavity components can be removed remotely through removable shield plugs and transferred to shielded work areas. Each reactor cavity can be isolated from the system for service and/or replacement without affecting the operation of the remainder.

IX. MAINTENANCE

A major area of uncertainty in fusion reactor design and operation is the reliability and lifetime of reactor components. This will be true until experience with reactor operation has been accumulated. Components which require frequent maintenance and/or repair and which result in reactor down-time can quickly render a reactor economically unattractive. The conceptual power plant design presented here has some major design features which are conducive to ease of repair and maintenance. Modular arrangement of reactor cavities will allow replacement, at reduced plant power, of first wall and optics associated with each cavity, i.e., only those modules which require maintenance need be shut down. Redundant lasers and power supplies provide for rapid switching and full power replacement and maintenance. On the other hand, the central optical switching system must operate very reliably and must be easily maintainable during scheduled power shutdown.

The SATURN reactor concept has a very desirable feature, namely the design for planned maintenance of the first wall to pre-empt catastrophic failure. The advantages of this approach to assure reliable power production are great.

X. SUMMARY AND CONCLUSIONS

A first iteration on the design of a 1000 MWe laser-fusion power plant has been completed. This power plant is based on the wetted wall reactor concept and CO₂ laser technology. The conceptual plant is modular in nature and is characterized by the following major features: (1) redundancy of essential components, including laser power amplifiers and electrical energy storage provide for reliable operation; (2) major subsystems such as reactor cavities, heat transfer loops, and lithium processing systems are isolated in separate structures and biological shielding is provided to minimize adverse vibrational effects on sensitive components as well as to minimize potential radioactive hazards; (3) remote handling systems are provided for servicing individual components without requiring total plant shutdown, thus enabling high load factors to be

obtained; and (4) utilization of the laser system, which represents a relatively large fraction of the total capital investment, is maximized by arranging for the laser system to serve all reactor cavities.

Although still highly conceptual in nature, these design studies have been useful in providing an understanding of potential engineering requirements. Many formidable problems have been identified; however, no problems have been discovered for which there are not reasonable conceptual solutions.

REFERENCES

1. Williams, J. M.; Finch, F. T.; Frank, T. G.; and Gilbert, J. S.; "Engineering Design Considerations for Laser Controlled Thermonuclear Reactors," Los Alamos Scientific Laboratory, Presented at the 5th Symposium on Engineering Problems of Fusion Research, Princeton, NJ, November 6-9, 1973.
Williams, J. M.; and Frank, T. G.; "Laser Controlled Thermonuclear Reactor Materials Requirements," Los Alamos Scientific Laboratory, Presented at the 1973 Winter Meeting of the American Nuclear Society, San Francisco, CA, November 11-15, 1973.
2. Booth, L. A. (Compiler), "Central Station Power Generation by Laser-Driven Fusion," Los Alamos Scientific Laboratory Report LA-4858-MS, Vol. I, February 1972.
3. Bohn, F.; Conrads, H.; Darvas, J.; Forster, S.; "Some Design Aspects of Inertially Confined Fusion Reactors," KFA Julich, Federal Republic of Germany, Presented at the 5th Symposium on Engineering Problems of Fusion Research, Princeton, NM, November 6-9, 1973.
4. Ritts, J. J.; Solomito, M.; and Steiner, D.; "Kerma Factors and Secondary Gamma-Ray Sources for Some Elements of Interest in Thermonuclear Blanket Assemblies," Oak Ridge National Laboratory Report ORNL-TM-3564 (1970).
5. Abdou, M. A.; and Maynard, C. W.; "MACK: A Program to Calculate Neutron Energy Release Parameters and Multigroup Neutron Reactions Cross Sections from ENDF/B," Trans. Am. Nucl. Soc., 16, 129 (1973).
6. Frank, T.; Freiwald, D.; Merson, T.; Devaney, J.; "A Laser Fusion Reactor Concept Utilizing Magnetic Fields for Cavity Wall Protection," Los Alamos Scientific Laboratory, Presented at 1st Topical Meeting on the Technology of Controlled Nuclear Fusion, San Diego, CA, April 16-18, 1974.
7. Fraas, A. P., "The BLASCON - an Exploding Pellet Fusion Reactor," Oak Ridge National Laboratory Report, TM-3231, July 1971.

TABLE I
CONCEPTUAL 1000 MWe LCTR PARAMETERS

Overall Plant

Thermal power per cavity, MW	156
Number of cavities	24
Overall energy gain per pellet microexplosion	134
Total thermal power, MW	3744
Circulating power, %	33
Net plant efficiency, %	27
Thermal-electric conversion efficiency, %	40

Reactor Cavity (Wetted Wall)

Pulse rate, s^{-1} /cavity	1.2
Reactor dimensions	
Cavity radius, m	1.7
Lithium blanket thickness, m	1.0
Reactor materials	
Structure	SS
First wall	Nb
Laser beams per cavity	8
Breeding ratio	~ 1.2

Lasers and Beam Transport

Number of laser power amplifiers	8 (with 100% redundancy)
Beam energy per laser power amplifier, MJ	0.135
Laser efficiency, %	7
Total electric power storage, MJ	20
Pulse rate, Hz	29
Number of mirrors per beam	9
Overall light transmissivity, %	93

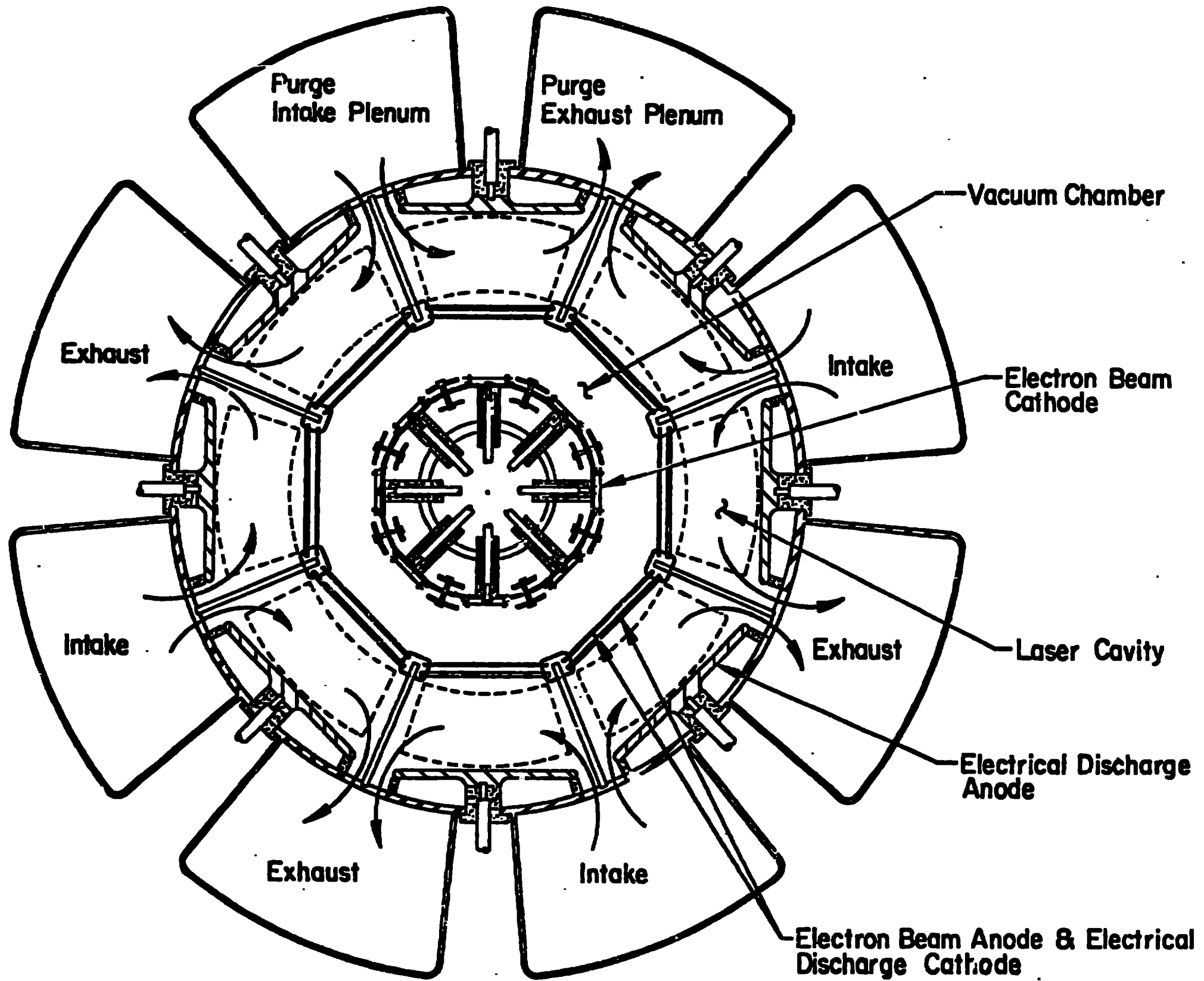

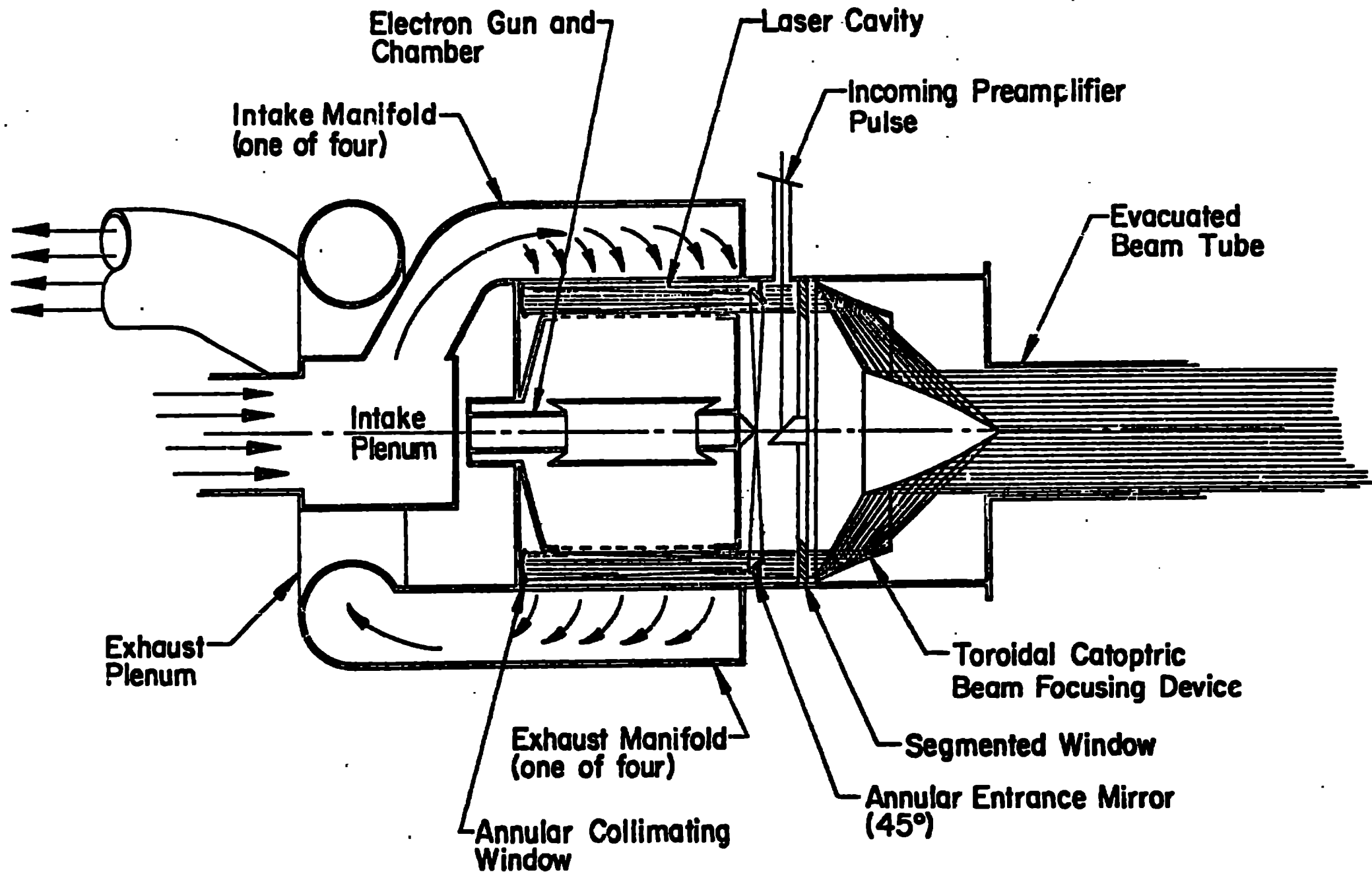
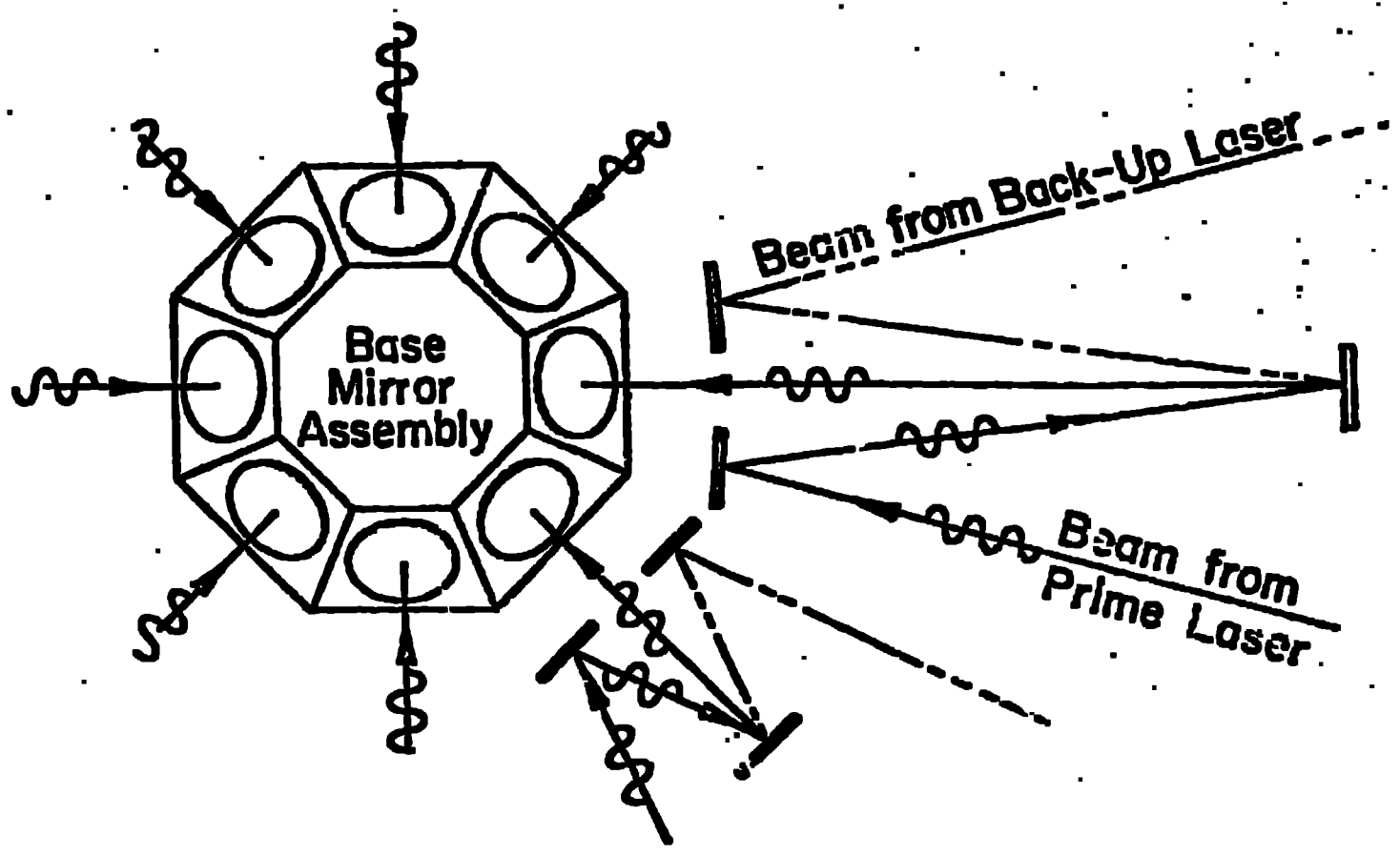
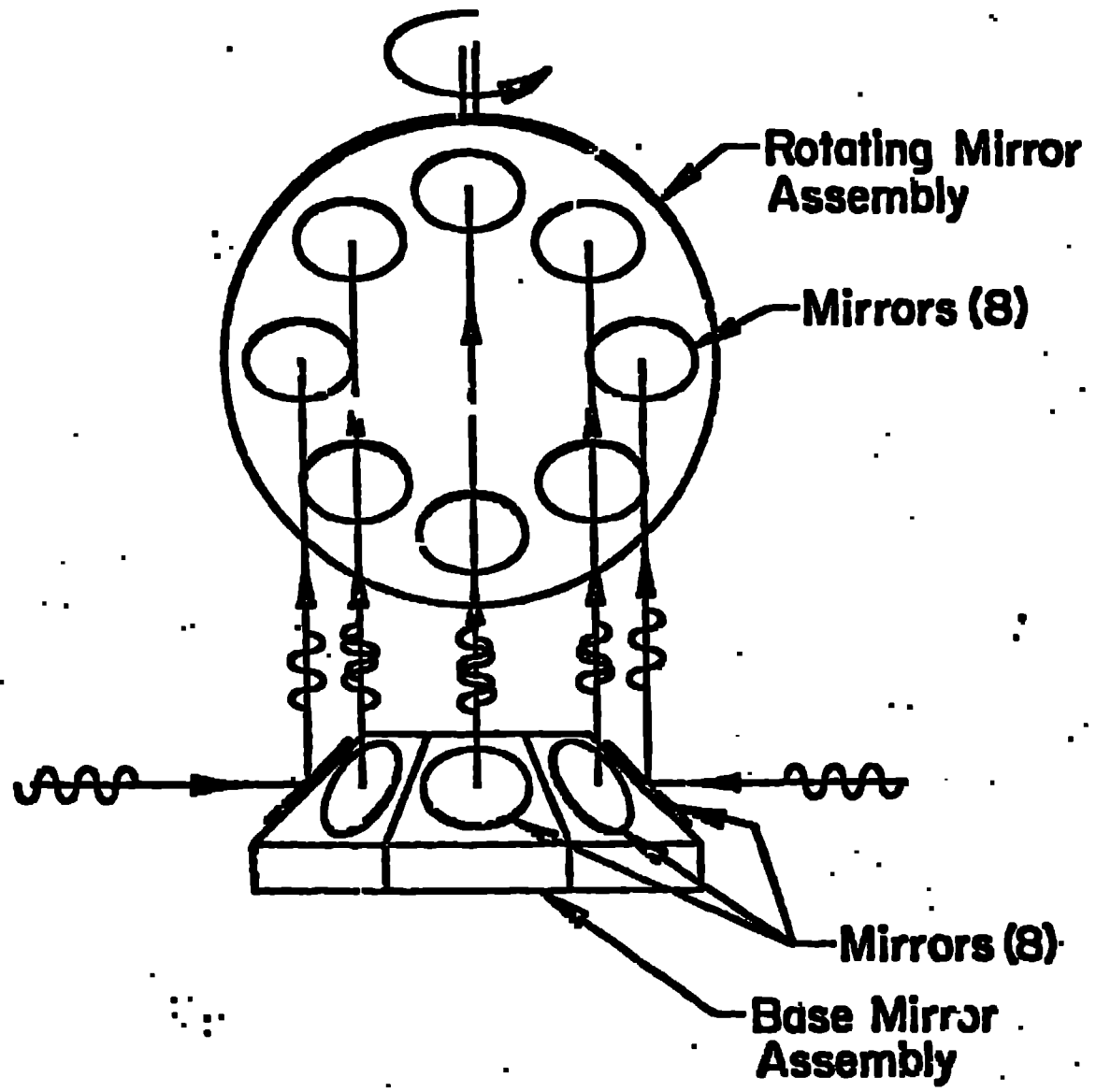
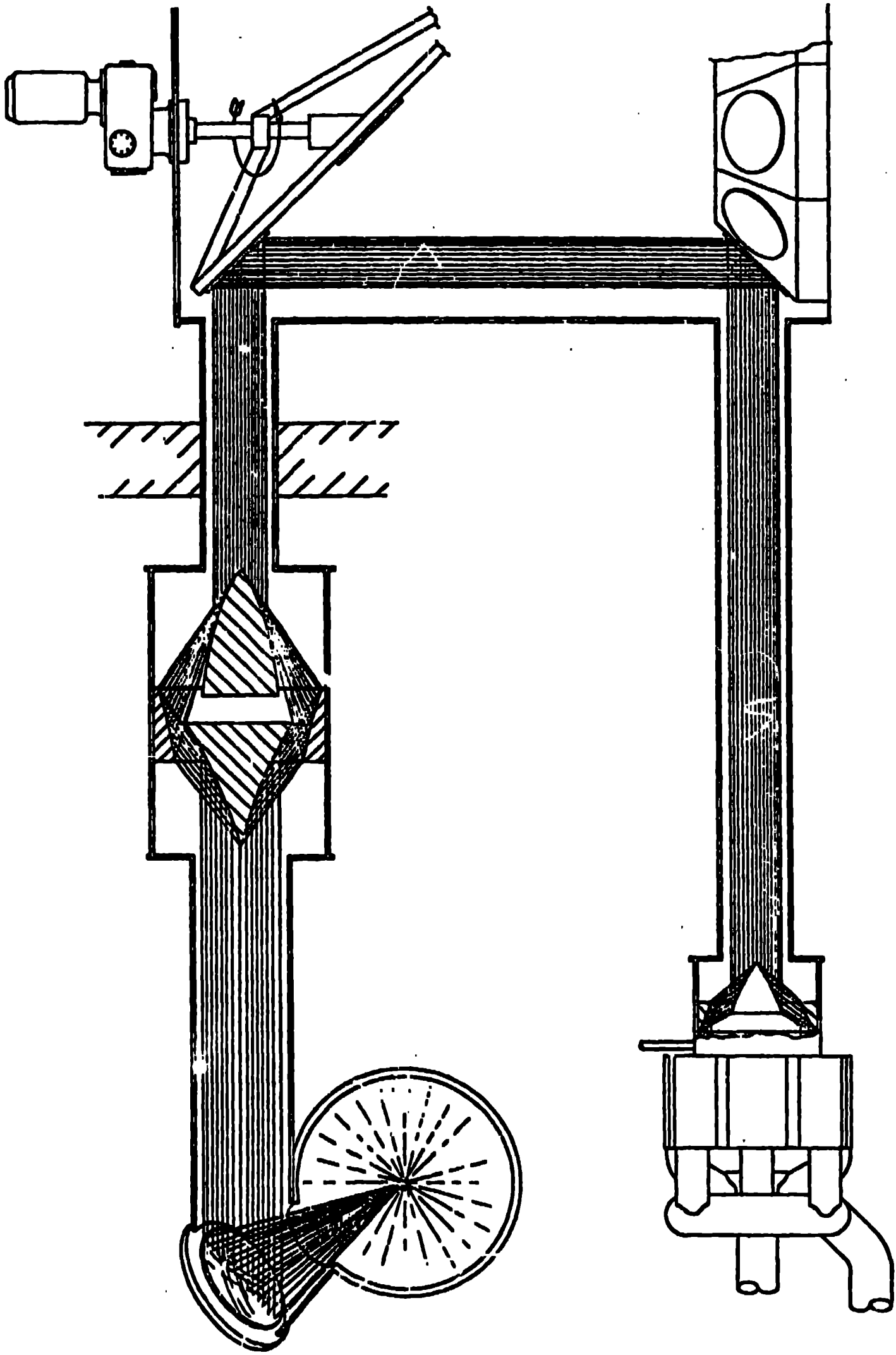

Fig 2

Handwritten notes in the top left corner, including the word "New" and other illegible scribbles.



Handwritten mark at the bottom center of the page.



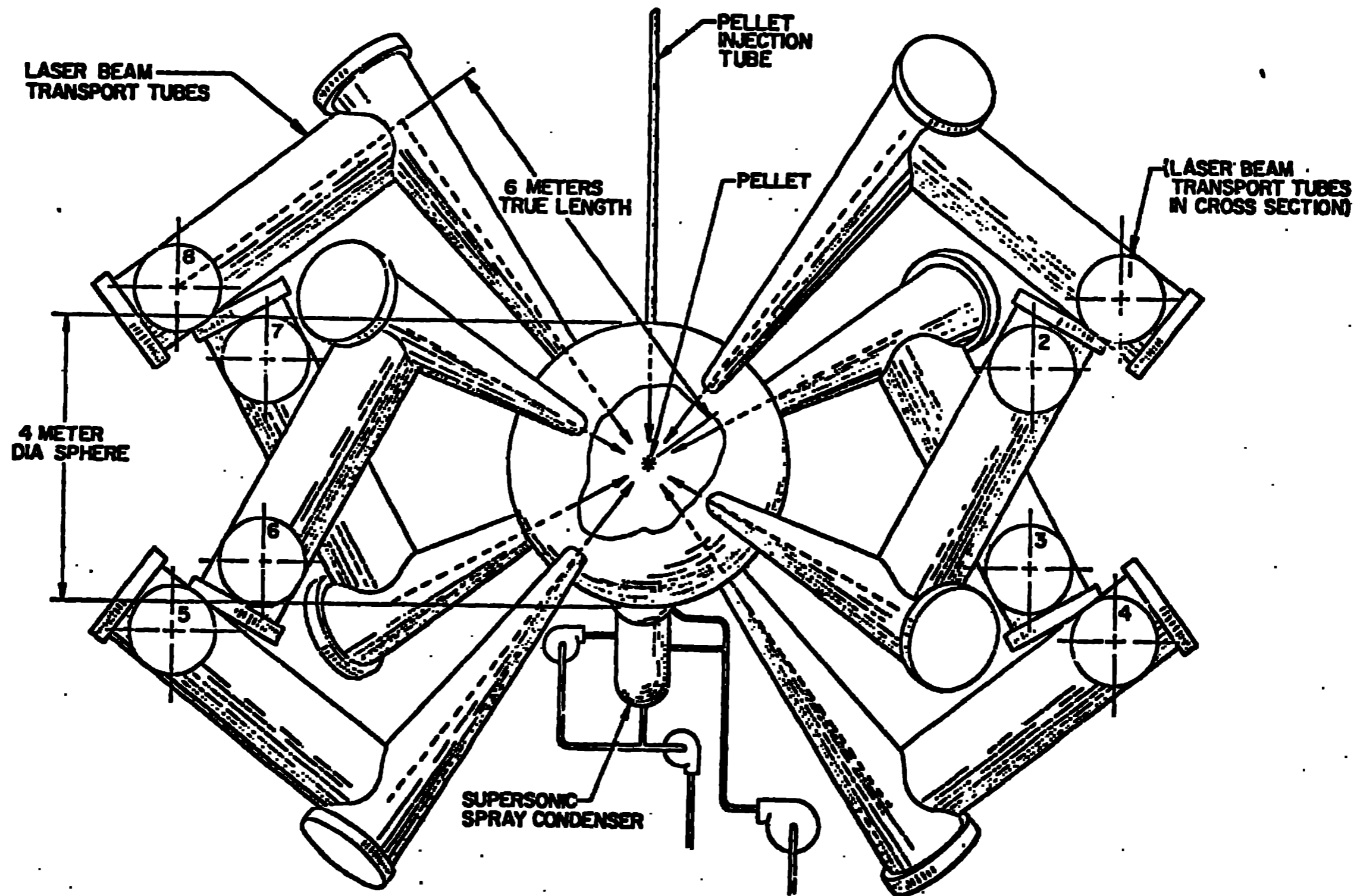

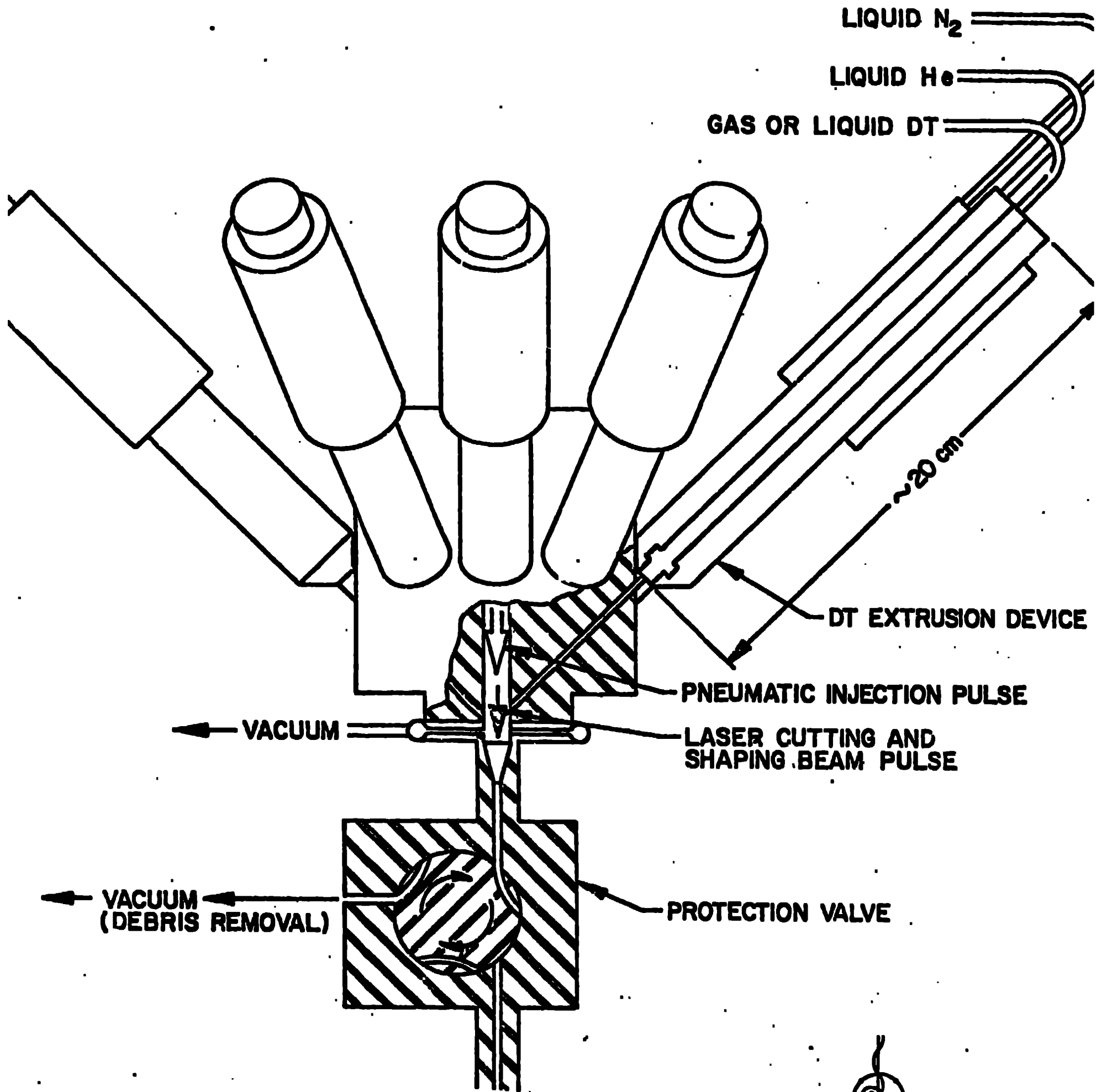

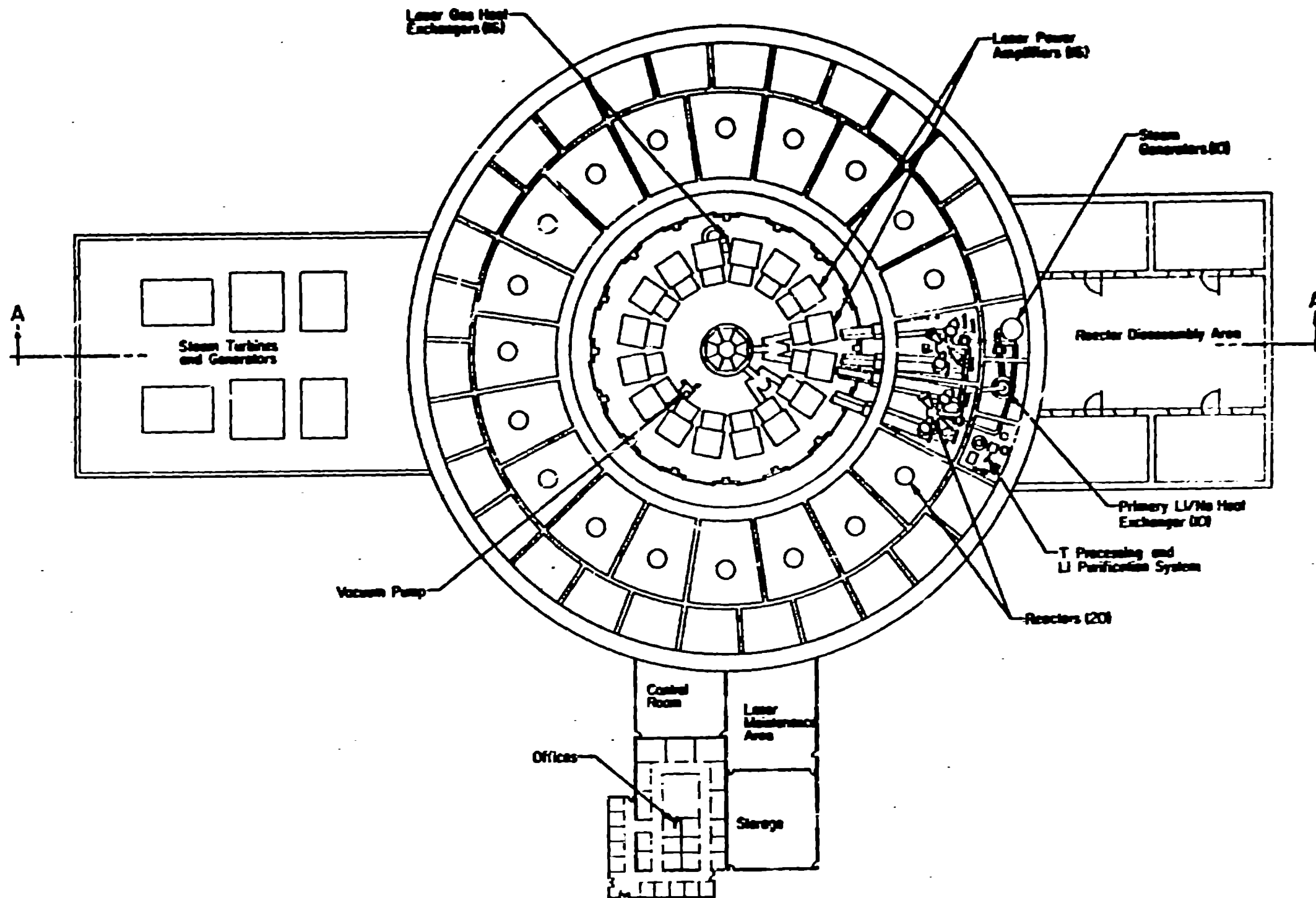

Conceptual 1000 MW (e) LCTR Power Plant

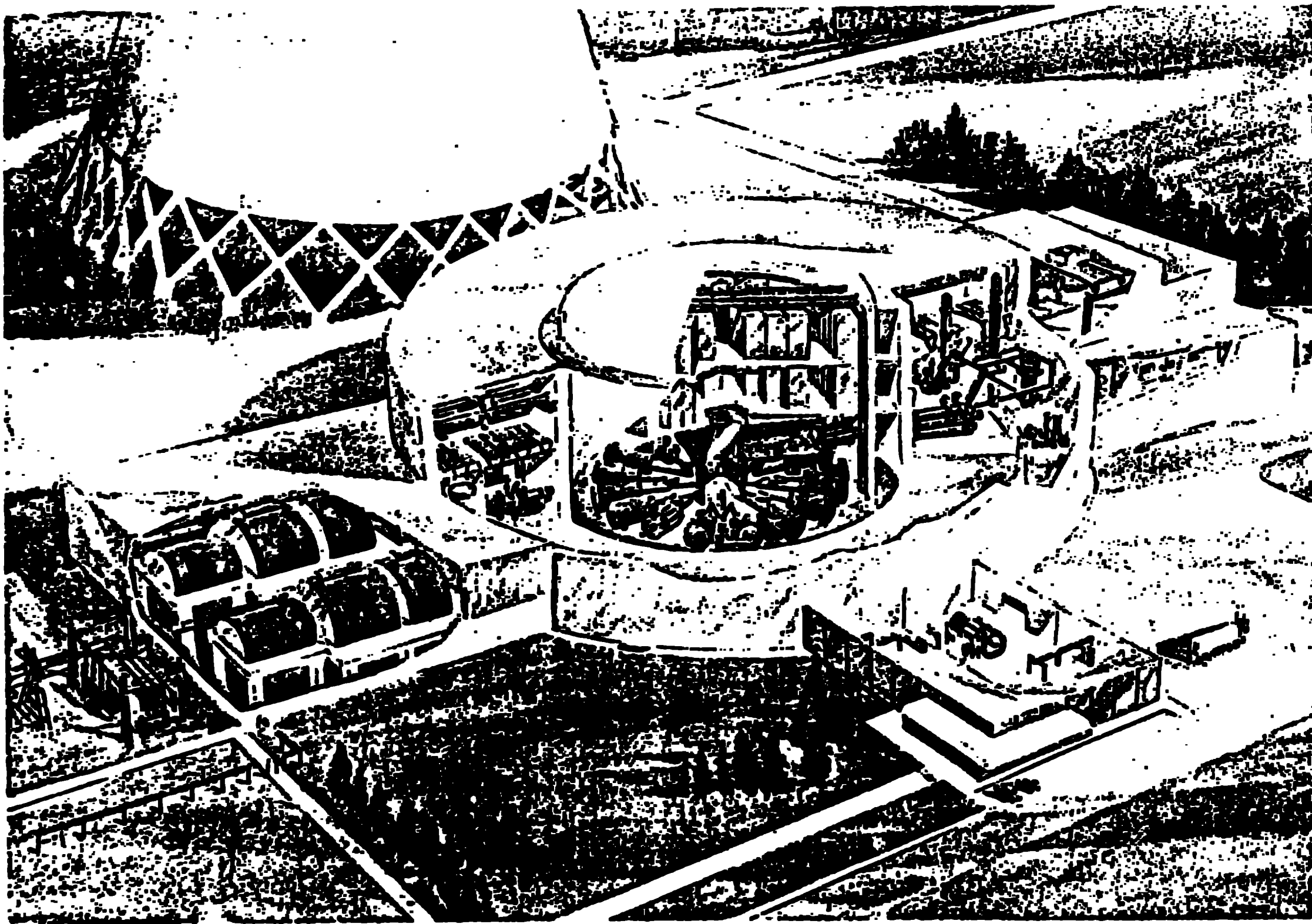

CONCEPTUAL 1000 MW(e) LCTR POWER PLANT

FIGURE CAPTIONS

1. Cross-sectional view of conceptual CO₂ laser power amplifier.
2. Axial view of conceptual CO₂ laser power amplifier.
- 3a. Conceptual beam-switching subsystem.
- 3b. Fixed mirror pedestal and selector mirrors enabling the choice of either of two power amplifiers to be used to provide each laser beam.
4. Schematic illustration of optical components in laser-beam-transport system.
5. Layout of beam tubes at a reactor cavity providing eight-sided illumination of fusion pellets.
6. Conceptual fuel pellet fabrication and injection system.
7. Conceptual 1000 MWe LCTR power plant (plan view).
8. Conceptual 1000 MWe LCTR power plant (elevation).
9. Conceptual 1000 MWe LCTR power plant.