

LA-3771

C. A.

LOS ALAMOS SCIENTIFIC LABORATORY
of the
University of California
LOS ALAMOS • NEW MEXICO

The Two-Dimensional Hydrodynamic Hot Spot
Volume IV



FOR REFERENCE

NOT TO BE TAKEN FROM THIS ROOM

CAT. NO. 1935

LIBRARY BUREAU

UNITED STATES
ATOMIC ENERGY COMMISSION
CONTRACT W-7405-ENG. 36

LEGAL NOTICE

This report was prepared as an account of Government sponsored work. Neither the United States, nor the Commission, nor any person acting on behalf of the Commission:

A. Makes any warranty or representation, expressed or implied, with respect to the accuracy, completeness, or usefulness of the information contained in this report, or that the use of any information, apparatus, method, or process disclosed in this report may not infringe privately owned rights; or

B. Assumes any liabilities with respect to the use of, or for damages resulting from the use of any information, apparatus, method, or process disclosed in this report.

As used in the above, "person acting on behalf of the Commission" includes any employee or contractor of the Commission, or employee of such contractor, to the extent that such employee or contractor of the Commission, or employee of such contractor prepares, disseminates, or provides access to, any information pursuant to his employment or contract with the Commission, or his employment with such contractor.

This report expresses the opinions of the author or authors and does not necessarily reflect the opinions or views of the Los Alamos Scientific Laboratory.

Printed in the United States of America. Available from
Clearinghouse for Federal Scientific and Technical Information
National Bureau of Standards, U. S. Department of Commerce
Springfield, Virginia 22151

Price: Printed Copy \$3.00; Microfiche \$0.65

LOS ALAMOS SCIENTIFIC LABORATORY
of the
University of California
LOS ALAMOS • NEW MEXICO

Report written: July 27, 1967

Report distributed: November 22, 1967

The Two-Dimensional Hydrodynamic Hot Spot
Volume IV

by

Charles L. Mader



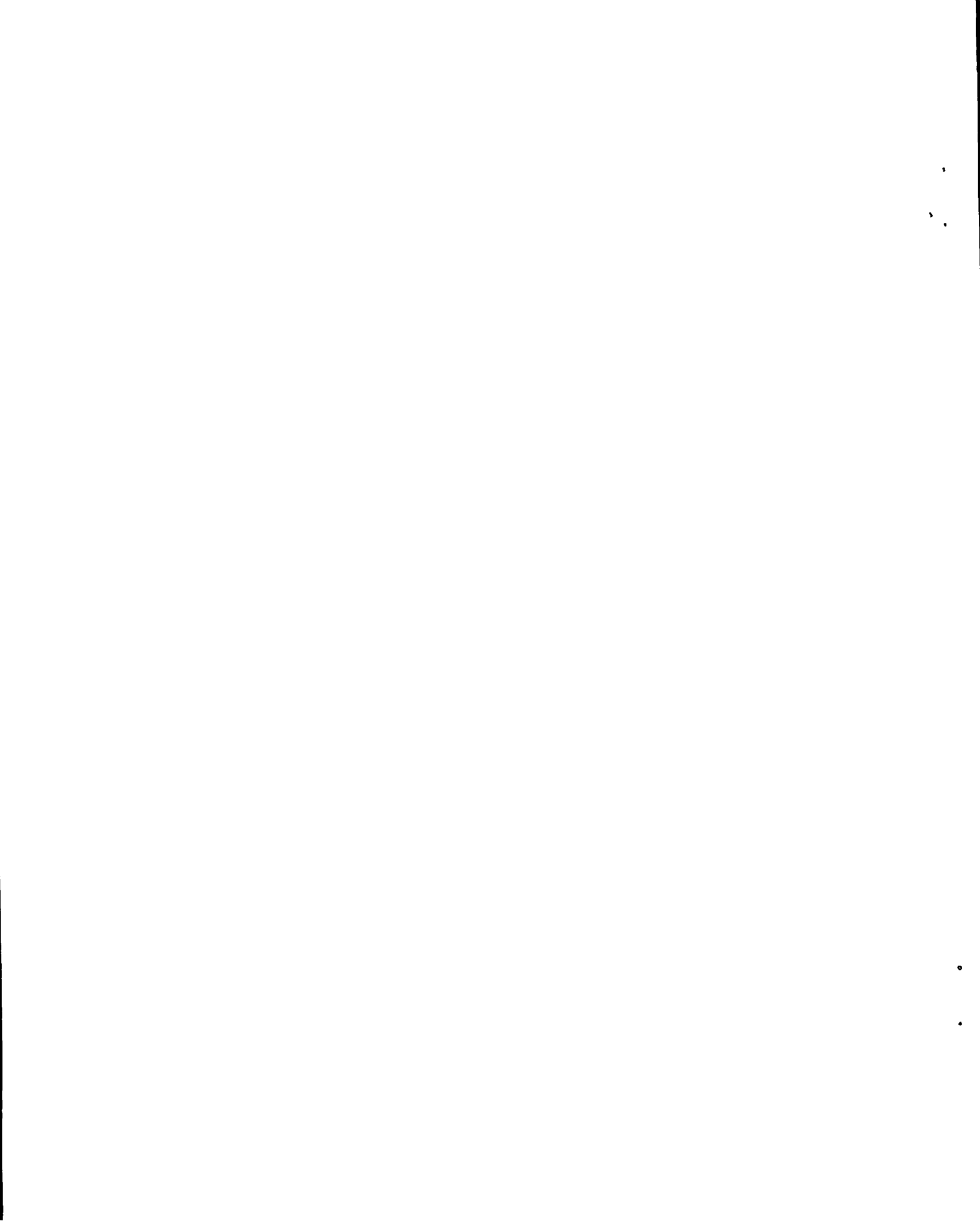

THE TWO-DIMENSIONAL HYDRODYNAMIC HOT SPOT

VOLUME IV

by

Charles L. Mader

ABSTRACT

The failure of a nitromethane detonation resulting from a side rarefaction cooling the explosive inside its reaction zone has been calculated using an Eulerian, reactive, numerical, hydrodynamic code. The velocity of the rarefaction agrees with the experimental measurements of Davis. The formation of hot spots from the interaction of a shock in nitromethane with a cylindrical or rectangular void, and the failure of the hot spot to initiate propagating detonation as a result of the rarefactions interacting with the reaction zone have been computed. The interaction of the hot spots formed from several voids has been computed. The basic two-dimensional processes involved in the shock initiation of heterogeneous explosives have been numerically described. Future studies of the basic processes will require three-dimensional geometry.

I. INTRODUCTION

To increase our understanding of the basic processes involved in the shock initiation of inhomogeneous explosives, we have studied theoretically the formation of hot spots from shocks interacting with discontinuities of various densities. In IA-3077¹ we described the hot spot formed when a shock in nitromethane interacts with a spherical void. In IA-3235² we described the hot spots formed when a shock in nitromethane interacts with cylindrical or conical nitromethane voids and with cylinders and spheres of aluminum. These reports were combined and published as Reference 3. The PIC (particle-in-cell) method was used for numerically solving the hydrodynamics.

We concluded that the PIC type of numerical hydrodynamics could be used to compute the interaction of a shock with a density discontinuity, the

formation of a hot spot, and buildup to propagating detonation. The failure of the resulting hot spot to initiate propagating detonation could be described in those cases in which the failure mechanism did not depend on the details of the structure of the reaction zone. The two-dimensional PIC calculations showed failure and propagation in approximately the same manner as did the one-dimensional hydrodynamic hot spot model.^{4,5} The PIC type of numerical hydrodynamics is not sufficiently detailed to describe the reaction zone with the required resolution or to describe the formation of low-temperature hot spots formed when shocks interact with corners.

As discussed in Reference 3, it was necessary to study the time-dependent reaction zone of homogeneous explosives before one could calculate cases that required resolved reaction zones. The stability of the reaction zone was studied in both one-dimensional⁶ and two-dimensional⁷ geometry. It was found

that the amount of overdrive necessary to stabilize the nitromethane and liquid TNT detonation decreases with decreasing activation energy and that nitromethane with an activation energy of 40 kcal/mole is stable to all perturbations at C-J velocity.

While the extensive study of the stability of the time-dependent reaction zone was in progress, the formation of low temperature hot spots by shocks in nitromethane interacting with corners of Plexiglas, aluminum, and gold was studied using a high resolution, two-dimensional, Lagrangian hydrodynamic code called 2DL. The formation of a hot spot and buildup to propagating detonation was computed, and the results agreed with the experimentally observed induction times of Travis and the radiographs of Venable.⁸

In LA-3297⁶ we described the failure of a propagating detonation because of rarefactions from the rear cooling the explosive in the reaction zone. One of the major problems that had to be solved for further understanding of the basic processes involved in the shock initiation of explosives (or in the failure diameter of explosives) was that of failure of propagating detonation because of side rarefactions cooling the explosive inside the reaction zone.

Unfortunately the present high resolution, Lagrangian, numerical hydrodynamic codes cannot handle problems with large distortion in the flow such as is present in the problems of failure of detonation waves and closure of voids. The Eulerian approach, however, is suitable for such problems, provided that only one component is present and free surfaces can be realistically treated. Therefore, the Eulerian code called 2DE⁹ was written to solve these problems. The results of our studies with this code are presented in this report.

The failure of a nitromethane detonation wave because of rarefactions from the side cooling the explosive inside the reaction zone is described. The velocity of the rarefaction is found to agree with the experimental findings of Davis.¹

Using the 2DE code, the closure of a cylindrical void and the failure of the hot spot can be calculated for cylindrical holes whose radii are within two orders of magnitude of the observed critical radius. The numerical resolution possible with present computers does not permit the reaction

zone to be adequately resolved for larger cylindrical holes.

This study is extended to include a shock interacting with two rectangular holes, and the interaction of two hot spots is described in detail. The enhanced shock wave formed from these hot spots is permitted to interact with two more rectangular holes, and the resulting hot spots are hotter, and more of the explosive is decomposed. On a gross scale, this behavior is similar to that of heterogeneous explosives in which the shock interacts with the density inhomogeneities, producing numerous local hot spots which decompose and liberate energy which strengthens the shock so that, when it interacts with additional inhomogeneities, hotter hot spots are formed and more explosive is decomposed. The shock wave grows stronger and stronger, releasing more and more energy, until it becomes strong enough to produce temperatures at which all of the explosive reacts and detonation begins.

II. FAILURE OF A NITROMETHANE DETONATION WAVE

Davis¹ has studied the failure of a supported nitromethane detonation wave traveling up a copper tube and then into a large container of nitromethane as shown in the following drawing.

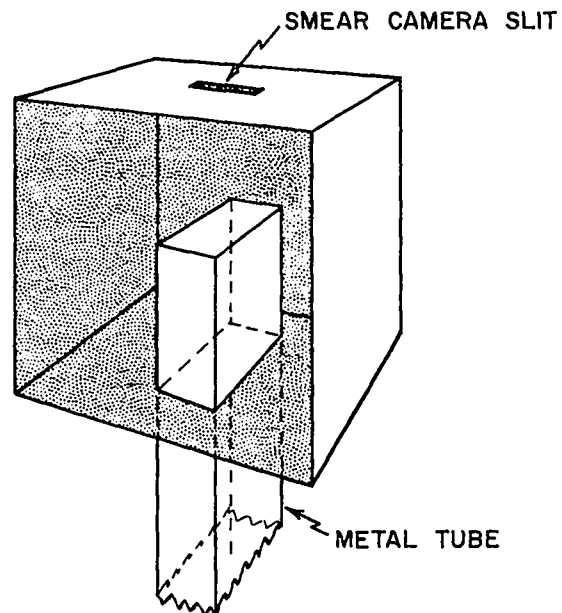

He observed rarefaction or "failure" waves that ran across the front at about 0.37 cm/ μ sec and that extinguished the detonation if the tube were small

enough. A smear-camera trace of such a failure is shown for a 1.02-cm-wide, 2.28-cm-long, rectangular tube that was 30-cm high.

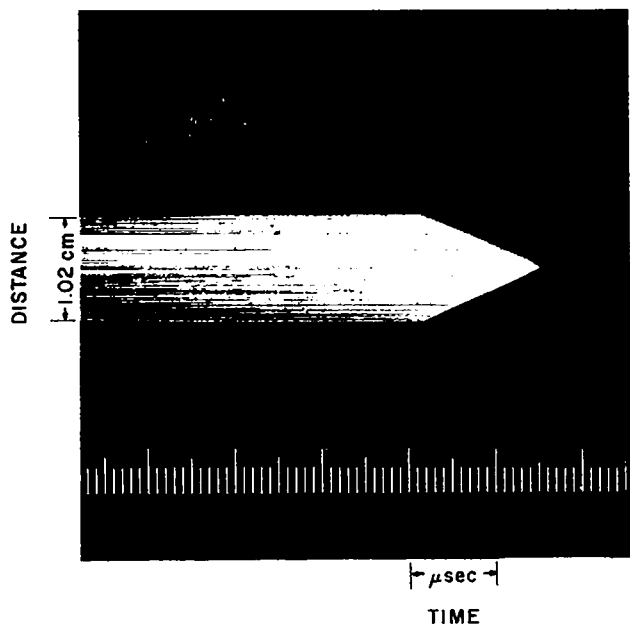

If the tube is larger, the detonation is not extinguished. A narrow failure or dark wave runs into the front, getting narrower as it progresses. This wave extinguishes detonation at its front, but reignition occurs at the rear and catches up with the wave. Under these circumstances the explosive in the box will detonate. These experiments demonstrate the basic processes involved in the problems of the failure of detonation, of the failure diameter of explosives, and of the "sputtering" initiation observed for density discontinuities near the critical size.

The light observed by Davis is thermal radiation from the hot explosive. Only near the end of the reaction zone is material hot enough to produce enough light for a high speed camera to record. Some of the light emitted is absorbed in the partially reacted explosive ahead of it, and if the reaction zone is thick enough, no light is recorded. The apparent discontinuity in light intensity which Davis recorded corresponds to a sharp change in the distance from the shock front to the region hot enough to produce recordable light. Rather than present the complete analysis of emission and absorption here, we assume for illustration that no

light is recorded when the distance from the shock front to the 3000° K isotherm becomes twice what it is for the high-order detonation. Fortunately, the change is so sudden and so large that the value obtained for the apparent velocity does not depend much upon the criterion chosen.

Figure 1 shows the isobars, and Fig. 2 the isotherms, of the failure of a nitromethane reaction zone resulting from side rarefactions, for an activation energy of 53.6 kcal/mole. Similar results were obtained for an activation energy of 40 kcal/mole. The reaction zone profiles for both activation energies vary only a few kilobars from the steady-state values during the time of interest in these calculations.⁷

The experimental arrangement is approximated numerically by a steady-state reaction zone flowing through 150 of the 300 cells near the lower boundary to approximate the top of the metal tube. The cell is a square of 40-A. For a γ of 0.68, an activation energy of 53.6 kcal/mole, and a frequency factor of 4×10^8 , the reaction zone of a C-J detonation of nitromethane occupies 2400 A, or 60 of the 300 cells, along the half-slab left boundary. The von Neumann spike pressure is 212 kbar, and the C-J pressure is 130 kbar. The use of a 300 x 300 mesh for a total of 90,000 cells is near the maximum resolution possible if one wishes to expend a reasonable amount (~ 24 h) of computer time.

Using the 3000° isotherms throughout the reaction zone, one obtains a rarefaction velocity of 0.4 ± 0.05 cm/ μ sec which is in good agreement with that found experimentally by Davis.

The failure of a slab of nitromethane with a void on the outside is shown in Fig. 3 with 300 x 300 cells. The radius of curvature is greater, and the rarefaction is stronger, for the nitromethane confined by a void than for nitromethane confined by nitromethane.

Using 100 x 100 cells, the failure of a slab of nitromethane confined by nitromethane is shown in Fig. 4, and the failure of a cylinder of nitromethane confined by nitromethane is shown in Fig. 5. The convergence of the rarefaction on the axis in cylindrical geometry results in a stronger rarefaction and consequently greater cooling of the reaction zone. The "hash" near the bottom center of the graphs is a result of having too complicated

a flow for the plotting routine to describe properly. Figures 1 through 3 are drawings of the machine printout with the "hash" eliminated.

Having demonstrated the failure of a detonation wave because of rarefactions from the side cooling the explosive inside the reaction zone, we now proceed to study the formation of hot spots and the initiation of an explosion which does not result in a propagating detonation.

III. THE INTERACTION OF A SHOCK WITH A CYLINDRICAL VOID

In LA-3235² we described the interaction of an 85-kbar shock in nitromethane with a 0.032-cm-radius, 0.032-cm-high, cylindrical void, using the PIC code. Figure 6 shows the isobars and isotherms computed for the same system using the Eulerian code. Figure 7 shows the isotherms computed using the Eulerian code and those reported in LA-3235² at approximately the same time after closure of the hole. Although the areas of the hot spots are approximately the same, the hottest region computed using the Eulerian code is smaller and about 500° cooler than that computed using the PIC code. The method of treating the free surface in the Eulerian code, which is to set the cell energy to zero until the cell density is greater than the initial density, gives too low a temperature, while the PIC method gives too high a temperature. The true value for such a problem lies between these two results. The agreement is sufficient to allow a semiquantitative study of the formation of hot spots, the resulting explosion, and failure to propagate.

Figure 8 shows the formation of a hot spot in nonreactive nitromethane from an 85-kbar shock interacting with a 3.2×10^{-4} -cm-radius cylindrical void. The nonreactive problem is scalable, and, hence, gives the solution for a hot spot of any radius. Figure 9 shows that the hot spot studied in Fig. 8 results in an explosion but fails to establish propagating detonation when chemical reaction is included. Figure 10 shows comparable results for a 2×10^{-5} -cm-radius cylindrical void with chemical reaction permitted.

A 3.2×10^{-4} -cm-radius hole is the largest that will result in a resolved reaction zone and, hence, permit failure of an explosion to occur in a 100 x 100 mesh of which the hole is 20 x 20.

This is two orders of magnitude smaller than the experimentally observed critical size. To obtain suitable resolution one would require a mesh of 10,000 x 10,000, or 100 million, cells. This is not a practical problem to solve with present computers.

We have demonstrated how a hot spot can explode but then fail to propagate because of rarefactions cooling the reactive detonation wave.

IV. THE INTERACTION OF A SHOCK WITH FOUR RECTANGULAR HOLES

The interaction of a shock with four rectangular voids, the bottom two with a half-width of 3.2×10^{-4} cm and the top two with a width of 3.2×10^{-4} cm, is shown in Fig. 11 for nonreactive nitromethane. The same problem with chemical reaction included is shown in Fig. 12.

While propagating detonation does not occur when the shock interacts with the first two holes, the enhancement of the shock wave by chemical reaction does produce a hotter hot spot upon interaction with the upper two voids. The hot spot is so hot that complete nitromethane decomposition occurs at the shock front. While a propagating detonation would not be expected to occur experimentally in this geometry of four holes (the computed detonation is the result of insufficient numerical resolution to resolve the reaction), the enhancement of the shock wave would be expected to occur experimentally. These calculations show the basic features of the shock initiation of heterogeneous explosives. A shock interacts with the density inhomogeneities, producing numerous local hot spots which explode but do not propagate, thereby liberating energy which strengthens the shock so that, when it interacts with additional inhomogeneities, hotter hot spots are formed and more of the explosive is decomposed. The shock wave grows stronger and stronger, releasing more and more energy, until it becomes strong enough to produce propagating detonation.

V. CONCLUSIONS

The failure of a nitromethane detonation resulting from side rarefactions cooling the explosive inside its reaction zone has been calculated. The velocity of the rarefaction agrees with the experimental measurements of Davis. The formation of hot

spots from the interaction of a shock in nitromethane with a cylindrical or rectangular hole, and the failure of the hot spot to initiate propagating detonation as a result of the rarefactions interacting with the reaction zone have been computed. The interaction of the hot spots formed from several holes has been computed.

The basic two-dimensional processes involved in the shock initiation of heterogeneous explosives have now been numerically described. The problem that remains is the study of the interaction of a shock with a matrix of holes in three-dimensional geometry. As the numerical solution of this problem must await the development of computing hardware that is 10 to 20 years in the future, it is unlikely that this author will be able to make the next contribution to the basic understanding of heterogeneous shock initiation. He hopes that the future contributor to this field, having seen the primitive struggles with the one- and two-dimensional hydrodynamic hot spot model, will call his advanced model the Three-Dimensional Hydrodynamic Hot Spot.

The basic two-dimensional processes involved in the failure of detonation, the failure diameter of explosives, and the "sputtering" initiation observed for density discontinuities near the critical size have been described. The three-dimensional study of the interaction of numerous failures and reignited detonations which is necessary for a complete numerical description of these problems must also await new computing hardware.

ACKNOWLEDGMENTS

The author gratefully acknowledges the assistance and contributions of W. C. Davis, W. Fickett, J. Travis, B. Craig, and L. C. Smith, of GMX Division; and R. Gentry, G. N. White, Jr., S. R. Orr, F. Harlow, and W. R. Gage, of T Division, of the Los Alamos Scientific Laboratory.

LITERATURE CITED

1. Mader, Charles L., "The Two-Dimensional Hydrodynamic Hot Spot," Los Alamos Scientific Laboratory report LA-3077, 1964.
2. Mader, Charles L., "The Two-Dimensional Hydrodynamic Hot Spot, Volume II," Los Alamos Scientific Laboratory report LA-3235, 1964.
3. Mader, Charles L., Phys. Fluids, 8, 1811 (1965).
4. Mader, Charles L., "The Hydrodynamic Hot Spot and Shock Initiation of Homogeneous Explosives," Los Alamos Scientific Laboratory report LA-2703, 1962.
5. Mader, Charles L., Phys. Fluids, 6, 375 (1963).
6. Mader, Charles L., "A Study of the One-Dimensional Time-Dependent Reaction Zone of Nitromethane and Liquid TNT," Los Alamos Scientific Laboratory report LA-3297, 1965.
7. Mader, Charles L., "The Time-Dependent Reaction Zones of Ideal Gases, Nitromethane, and Liquid TNT," Los Alamos Scientific Laboratory report LA-3764, 1967.
8. Mader, Charles L., "The Two-Dimensional Hydrodynamic Hot Spot, Volume III," Los Alamos Scientific Laboratory report LA-3450, 1966.
9. Gage, William R., and Mader, Charles L., "2DE - A Two-Dimensional Eulerian Hydrodynamic Code for Computing One-Component Reactive Hydrodynamic Problems," Los Alamos Scientific Laboratory report LA-3629-MS, 1966.

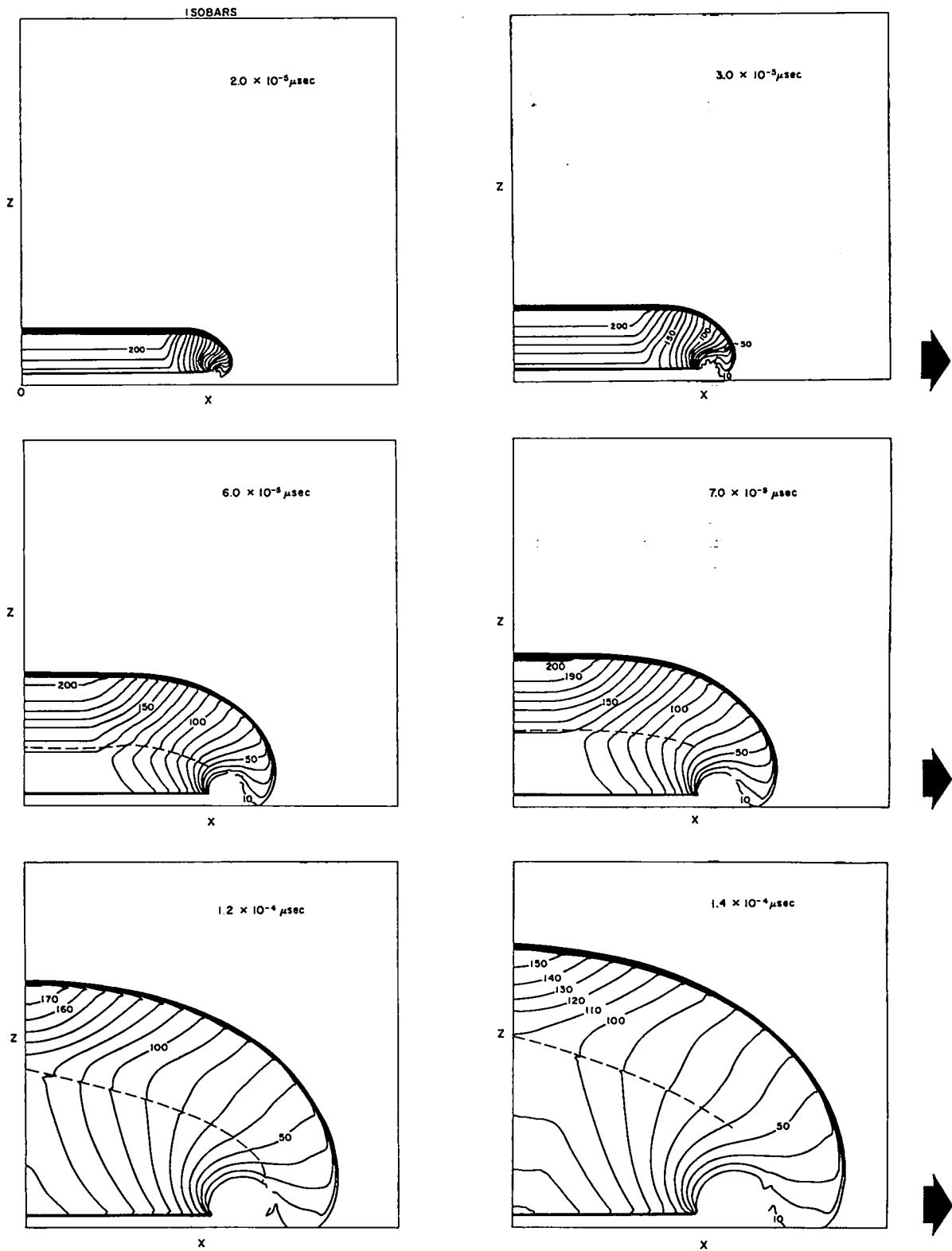
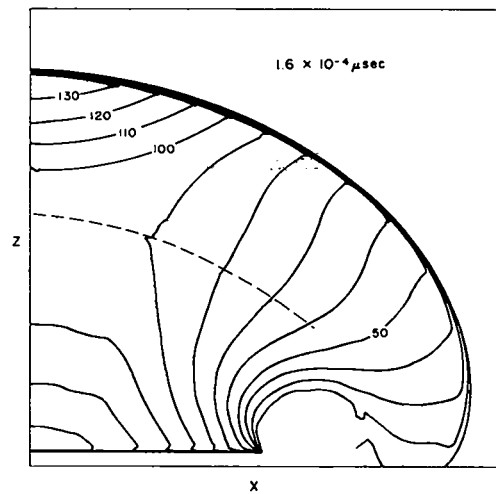
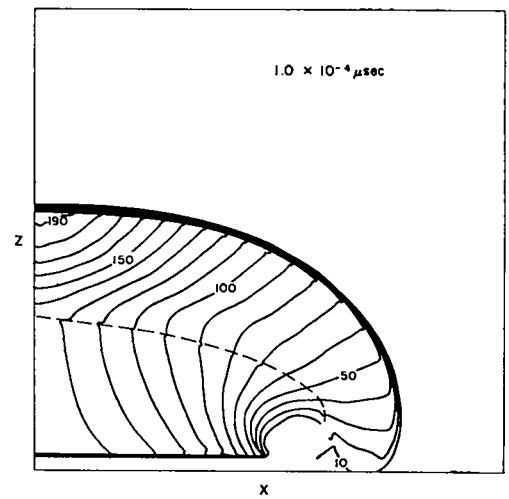
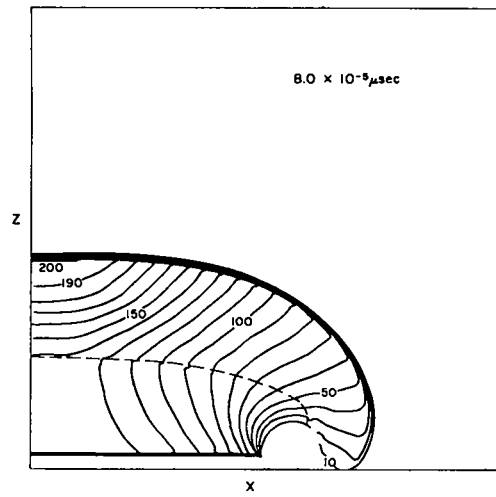
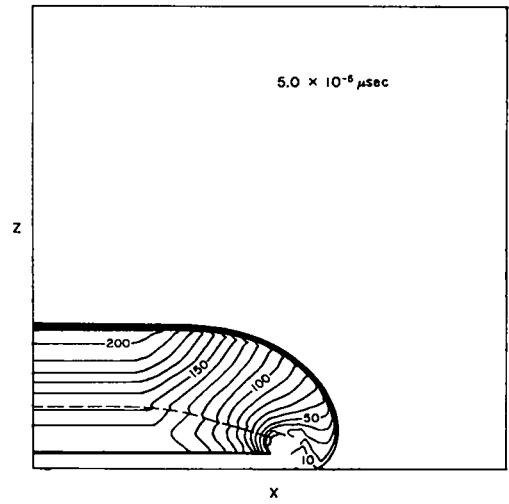
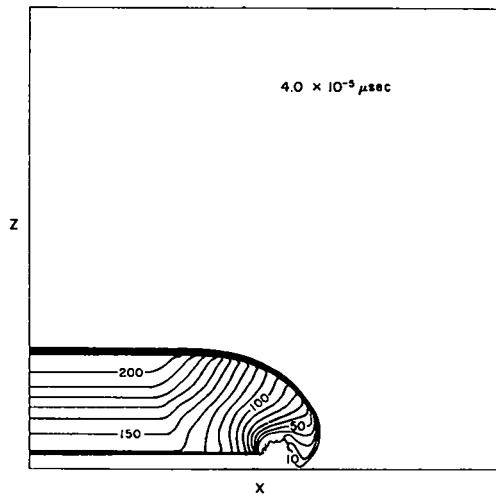

Fig. 1. The computed isobars for a supported slab nitromethane C-J detonation wave passing into a box of nitromethane. The interval between isobars is 10 kbar. The dashed line is the location of the end of the reaction zone. 300×300 40-A-square cells were used.



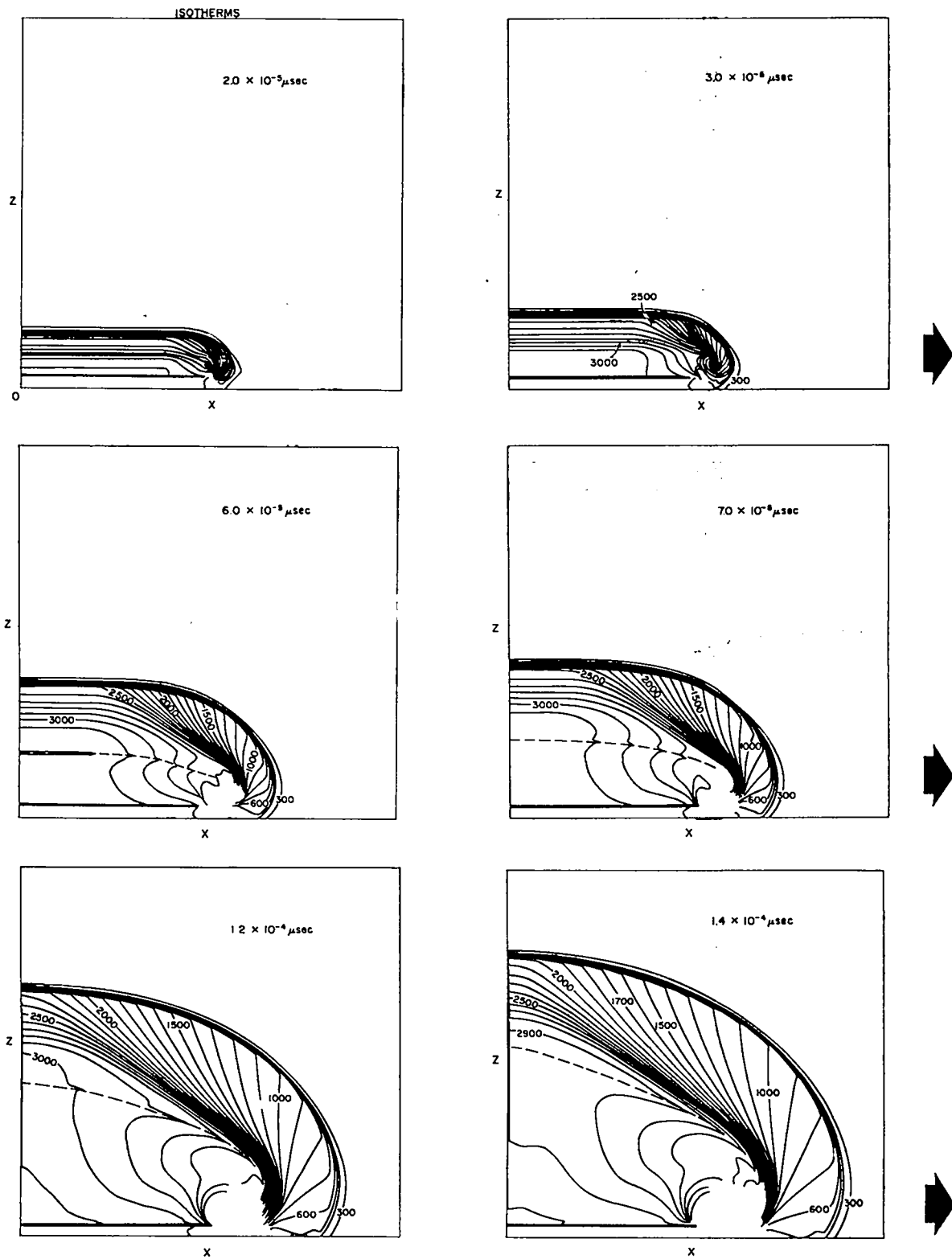
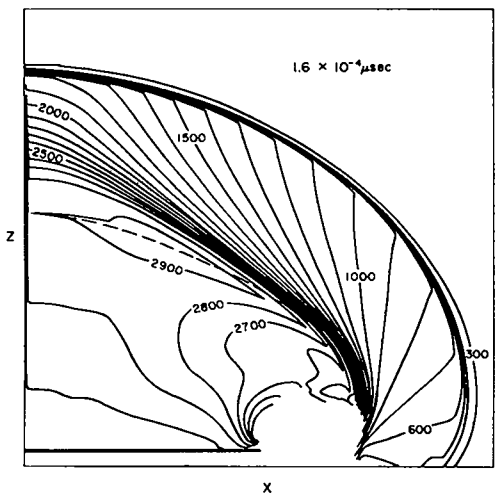
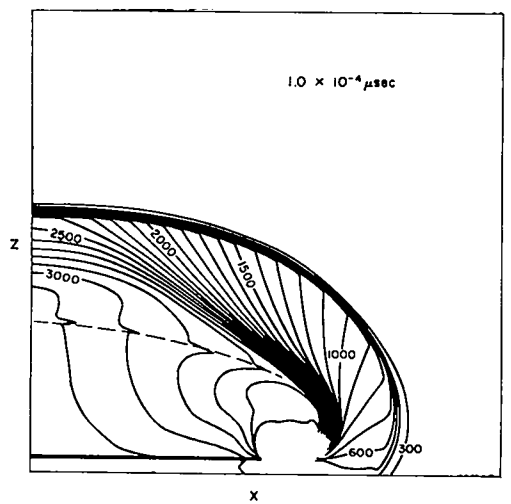
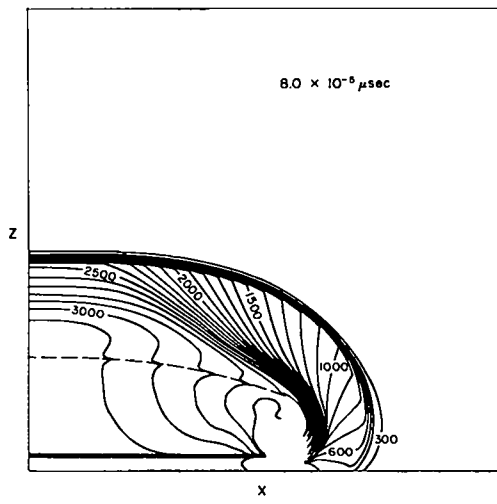
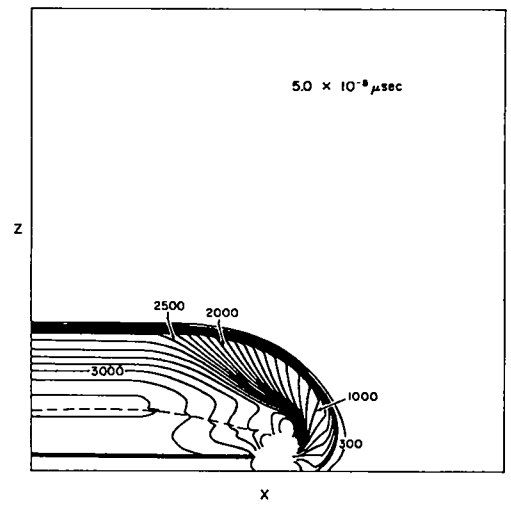
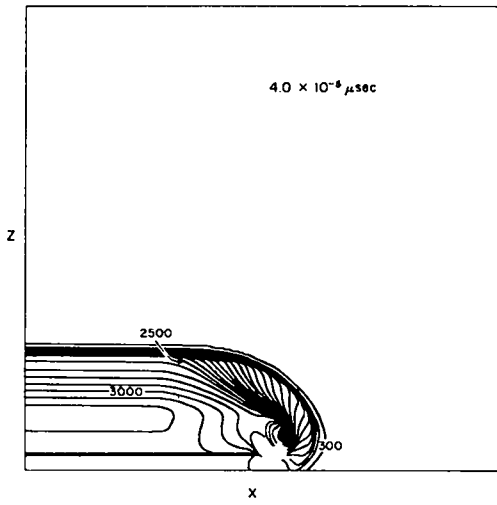

Fig. 2. The computed isotherms for a supported slab nitromethane C-J detonation wave passing into a box of nitromethane. The interval between isotherms is 100° Kelvin. The dashed line is the location of the end of the reaction zone. The isotherms are shown at the same times as the isobars in Fig. 1. 300×300 40-A-square cells were used.



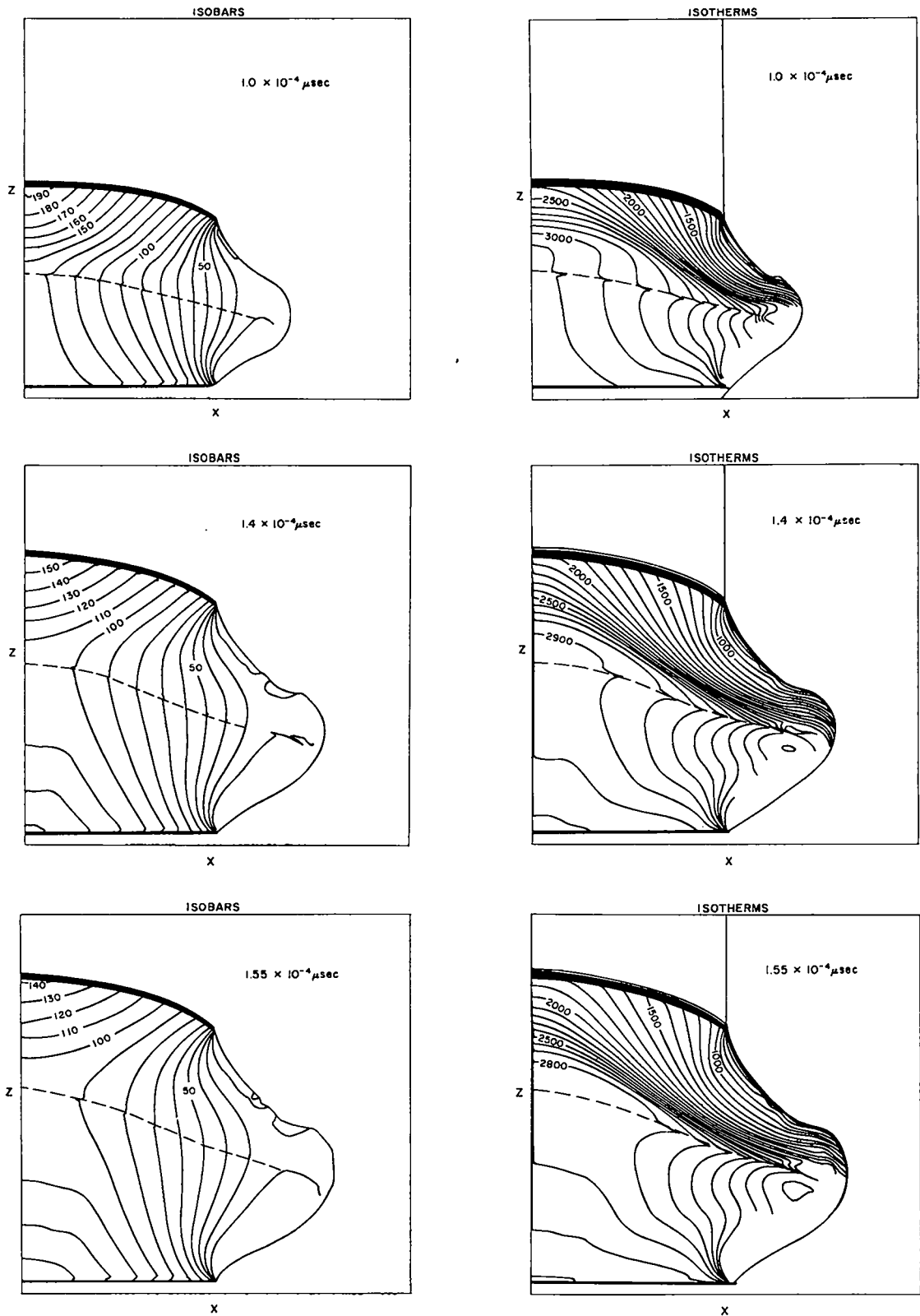

Fig. 3. The computed isobars and isotherms for a supported slab nitromethane C-J detonation wave passing into a slab of nitromethane with a void on the right side of the slab. The dashed line is the location of the end of the reaction zone. 300×300 40-A-square cells were used.

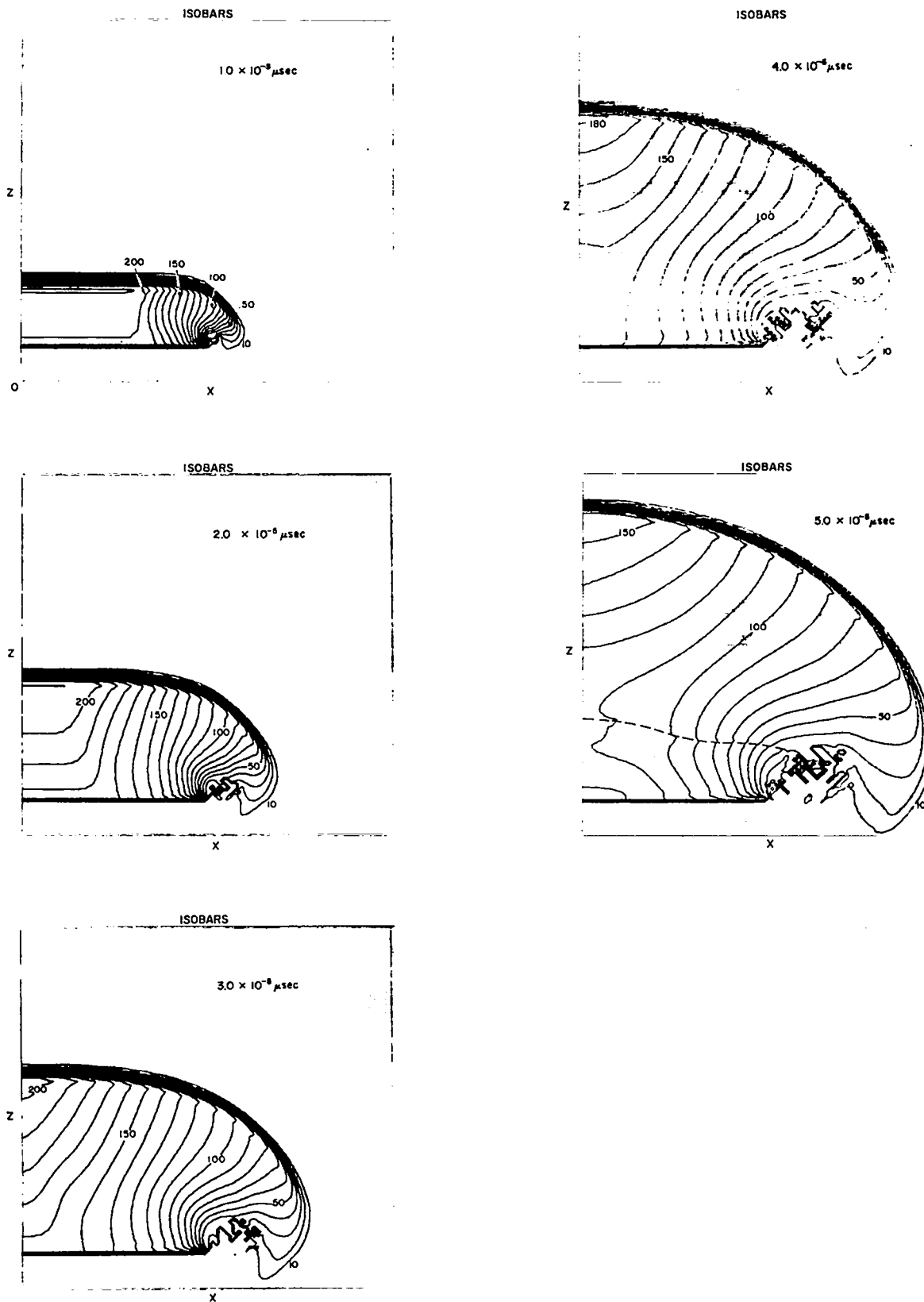
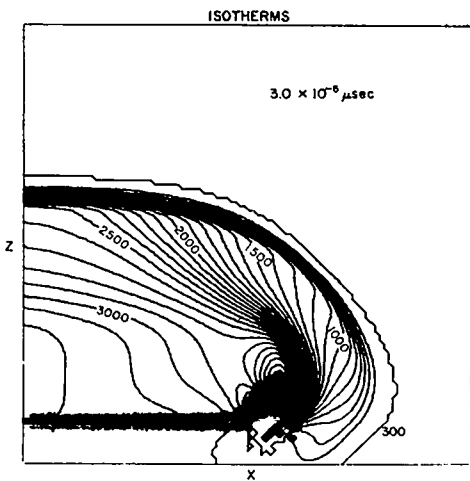
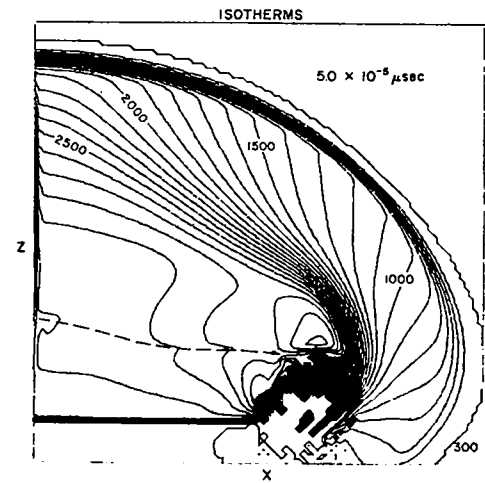
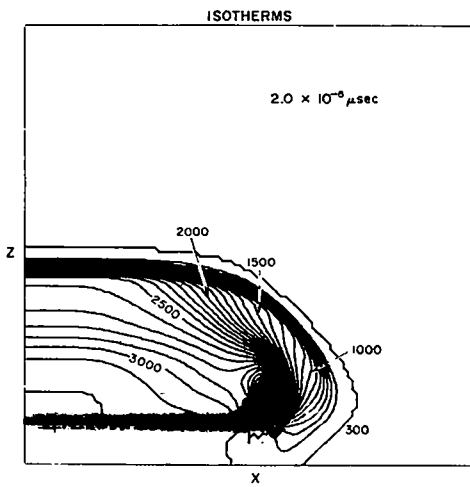
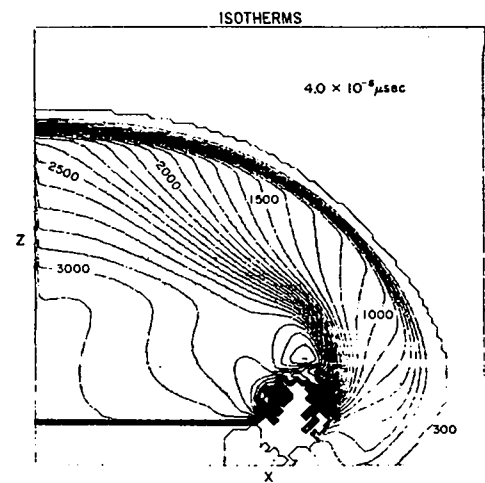
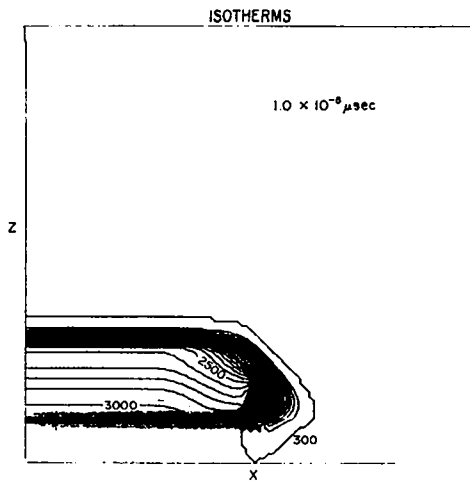

Fig. 4. The computed isobars and isotherms for a supported slab nitromethane C-J detonation wave passing into a box of nitromethane. The interval between isobars is 10 kbar, and that between isotherms is 100° Kelvin. The dashed line is the location of the end of the reaction zone. 100×100 40-A-square cells were used.



4. (Continued)

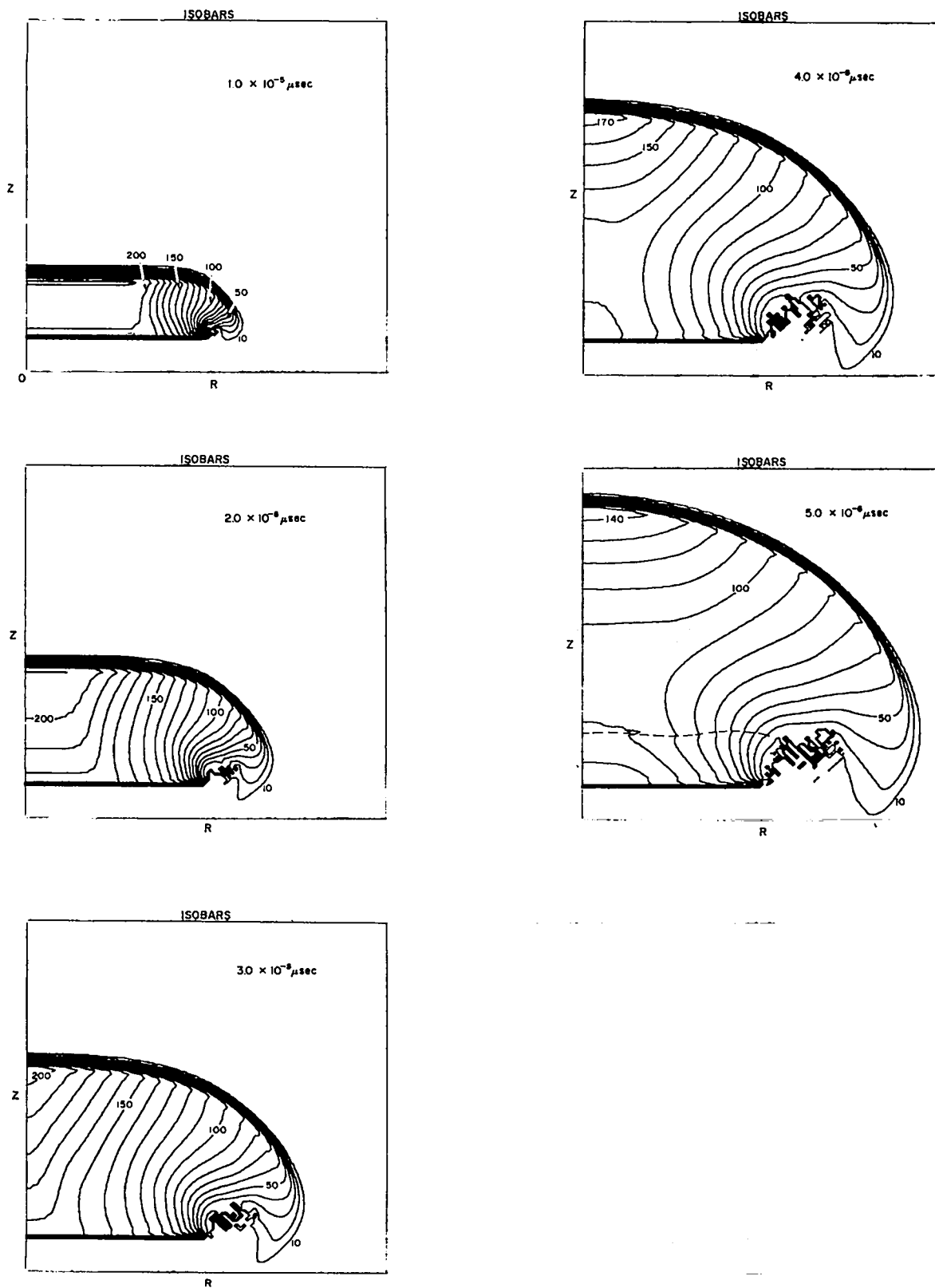

Fig. 5. The computed isobars and isotherms for a supported cylindrical nitromethane C-J detonation wave passing into a cylinder of nitromethane. The interval between isobars is 10 kbar and that between isotherms is 100° Kelvin. The dashed line is the location of the end of the reaction zone. 100×100 40-A-square cells were used.

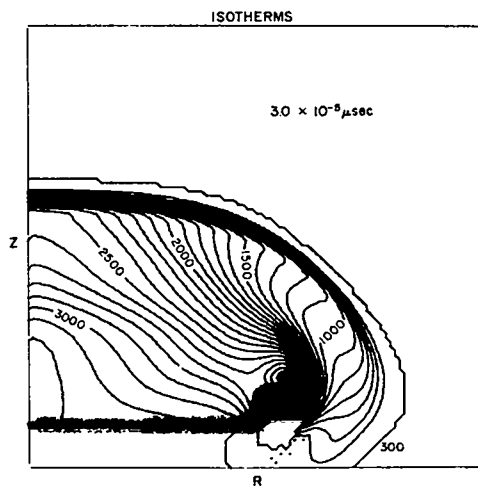
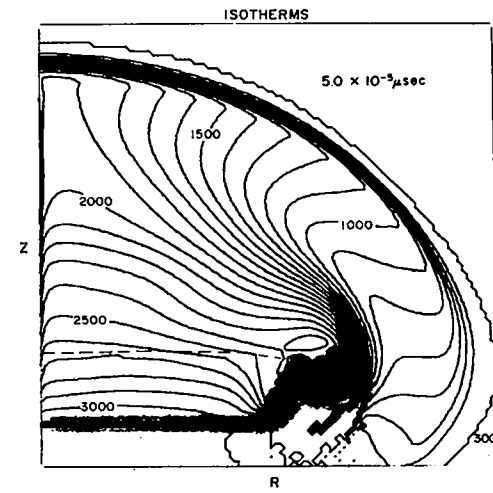
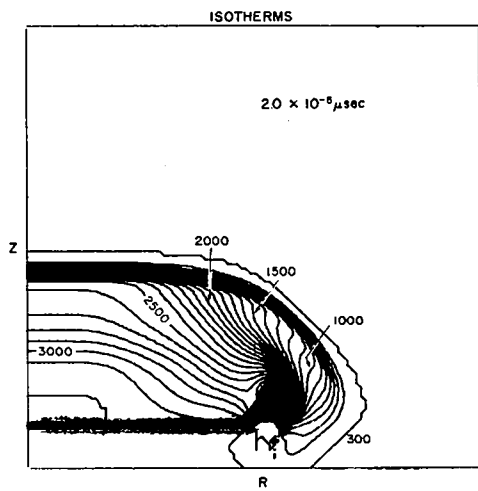
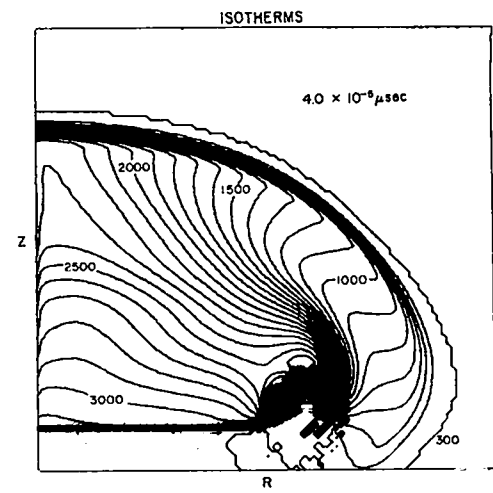
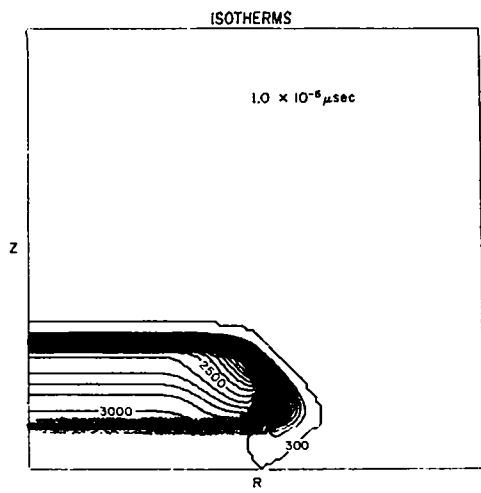

Fig. 5. (Continued)

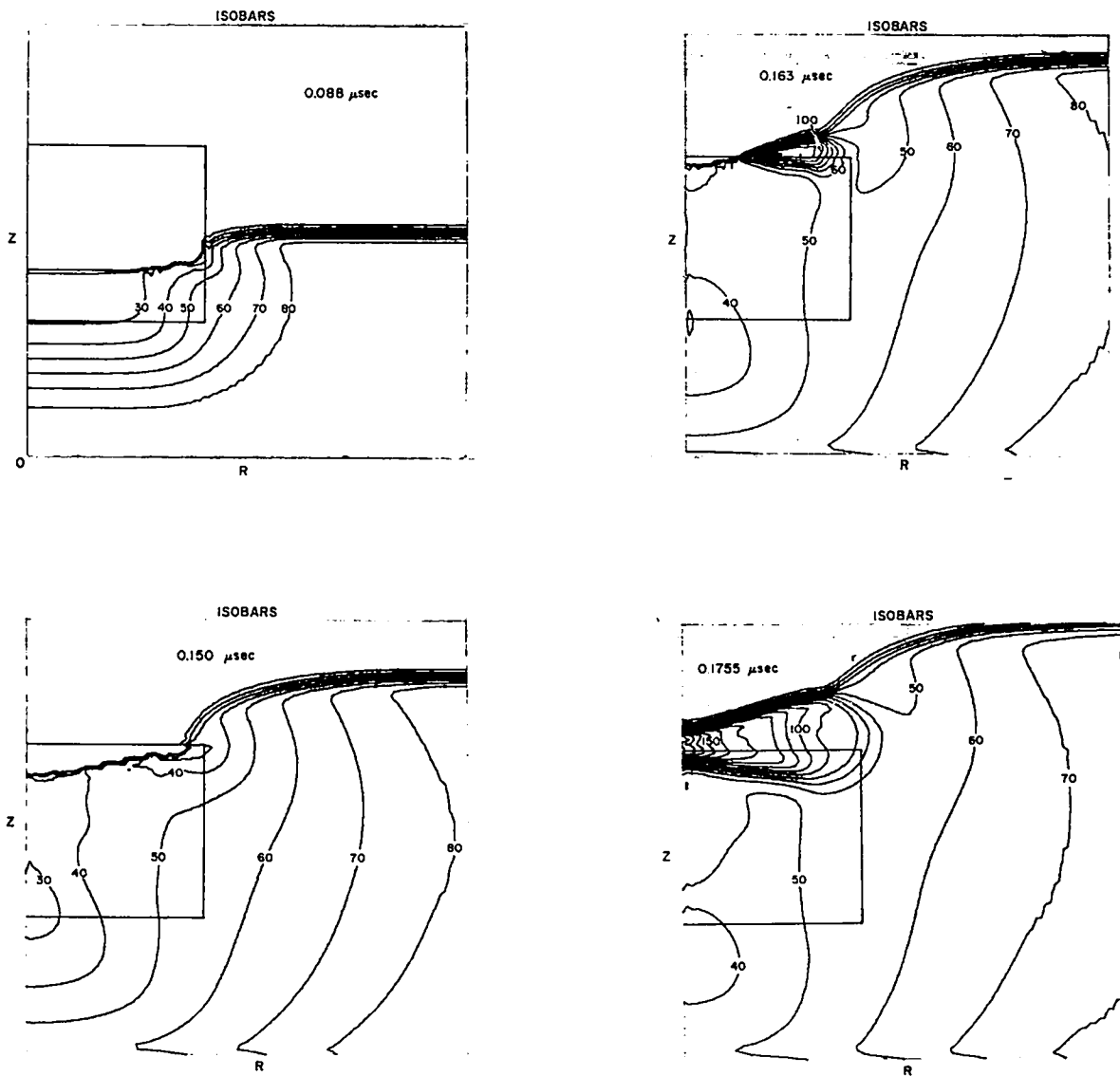

Fig. 6. The computed isobars and isotherms for an 85-kbar shock interaction with a 0.032-cm-radius, 0.032-cm-high, cylindrical void in a 0.08-cm-radius, 0.08-cm-high cylinder of nitromethane. Chemical reaction is not permitted. The interval between isobars is 10 kbar, and that between isotherms is 500° Kelvin. The original position of the void is shown.

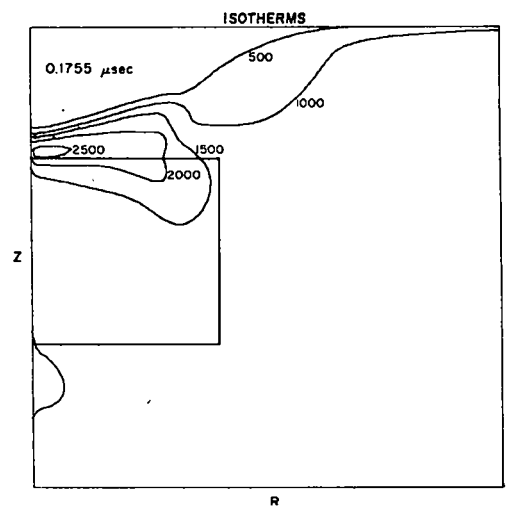
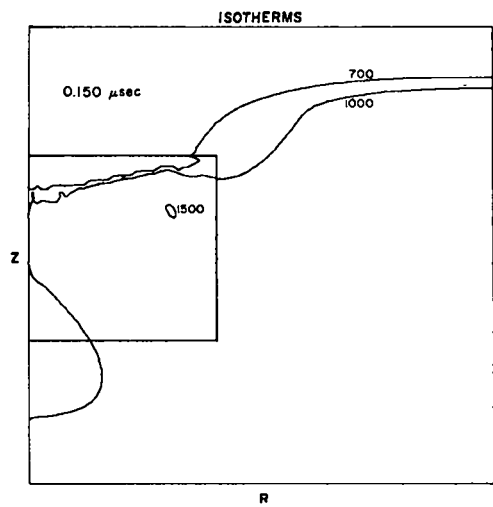
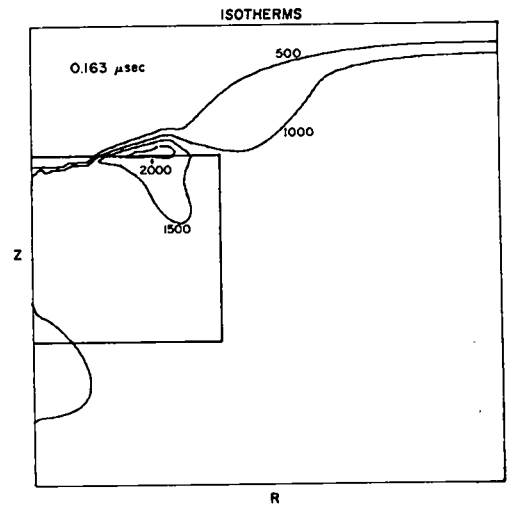
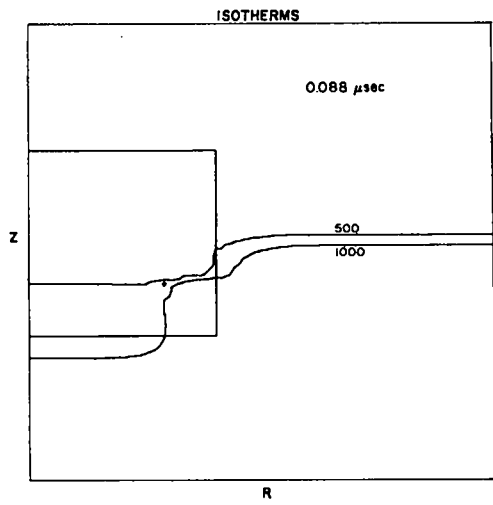

Fig. 6. (Continued)

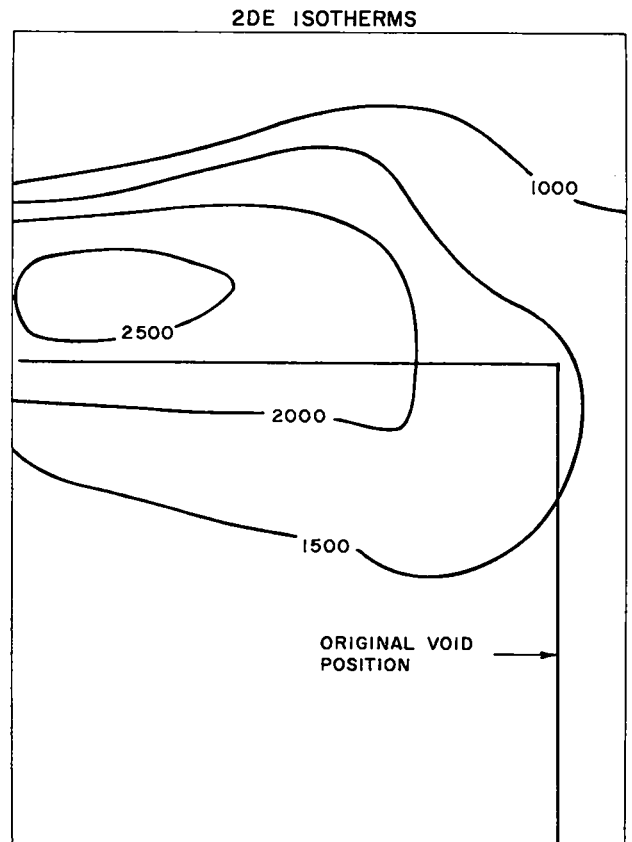
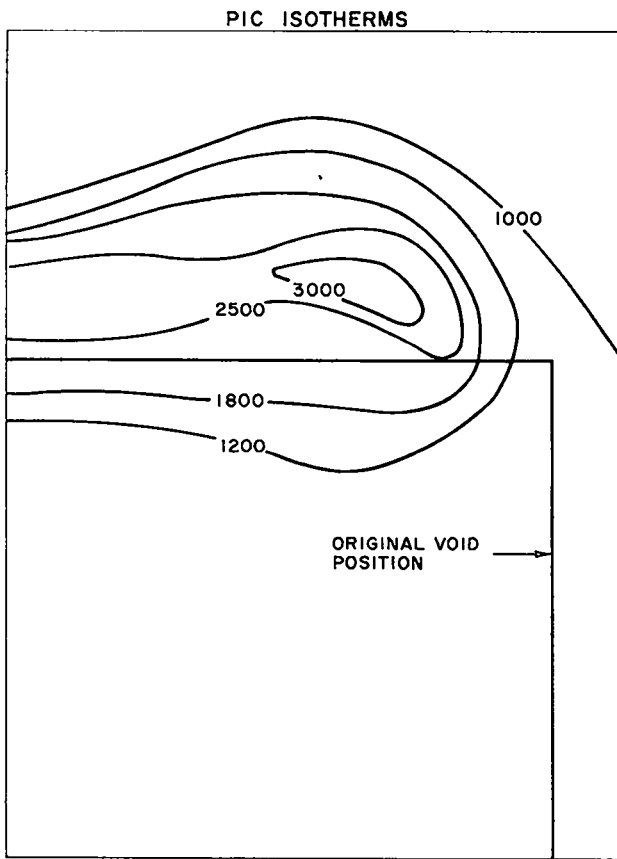

Fig. 7. The isotherms computed using the PIC and 2DE numerical hydrodynamic codes, at approximately the same time after closure of a 0.032-cm-radius, 0.032-cm-high, cylindrical void in nitromethane.

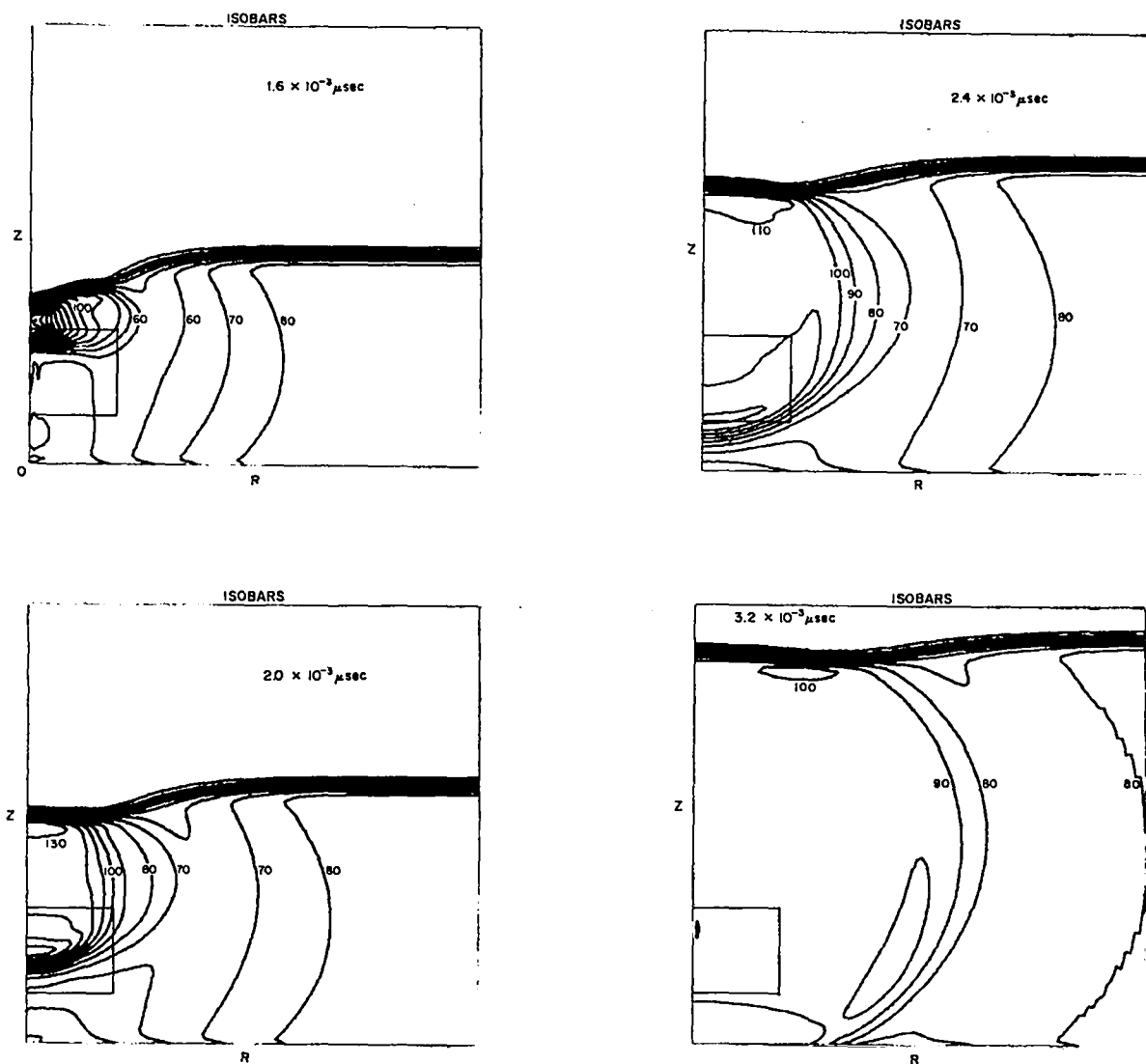

Fig. 8. The computed isobars and isotherms of an 85-kbar shock interacting with a 3.2×10^{-4} -cm-radius, 3.2×10^{-4} -cm-high, cylindrical hole in a 1.6×10^{-3} -cm-radius, 1.6×10^{-3} -cm-high cylinder of nitromethane. Chemical reaction is not permitted. The interval between isobars is 10 kbar, and that between isotherms is 500° Kelvin. The original position of the void is shown.

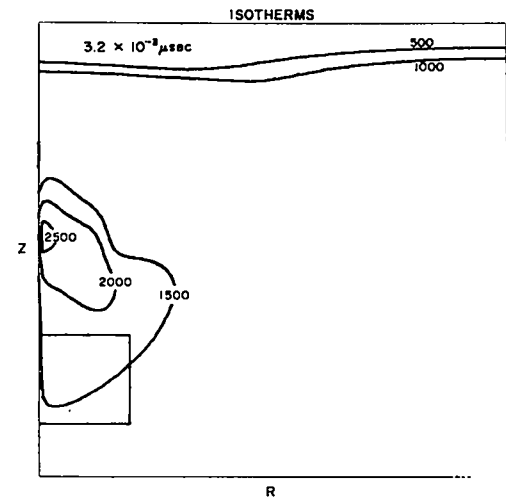
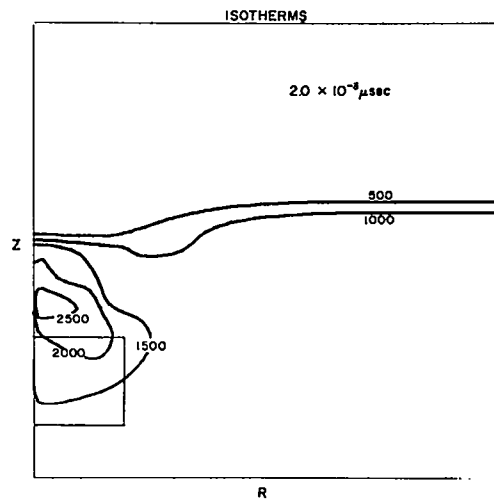
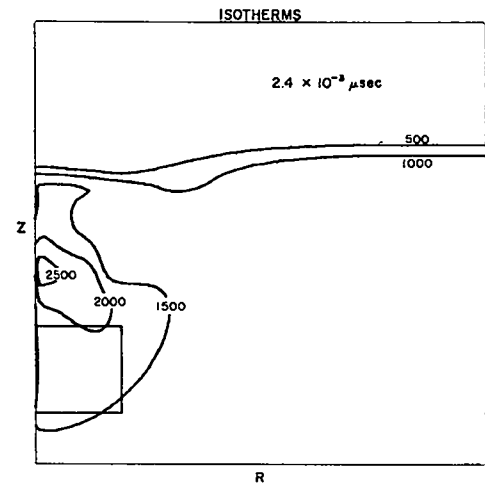
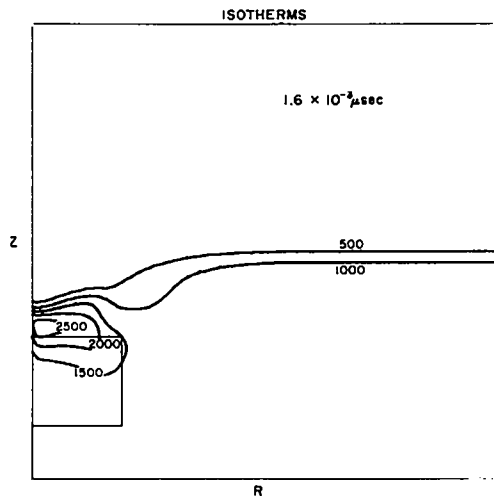

Fig. 8. (Continued)

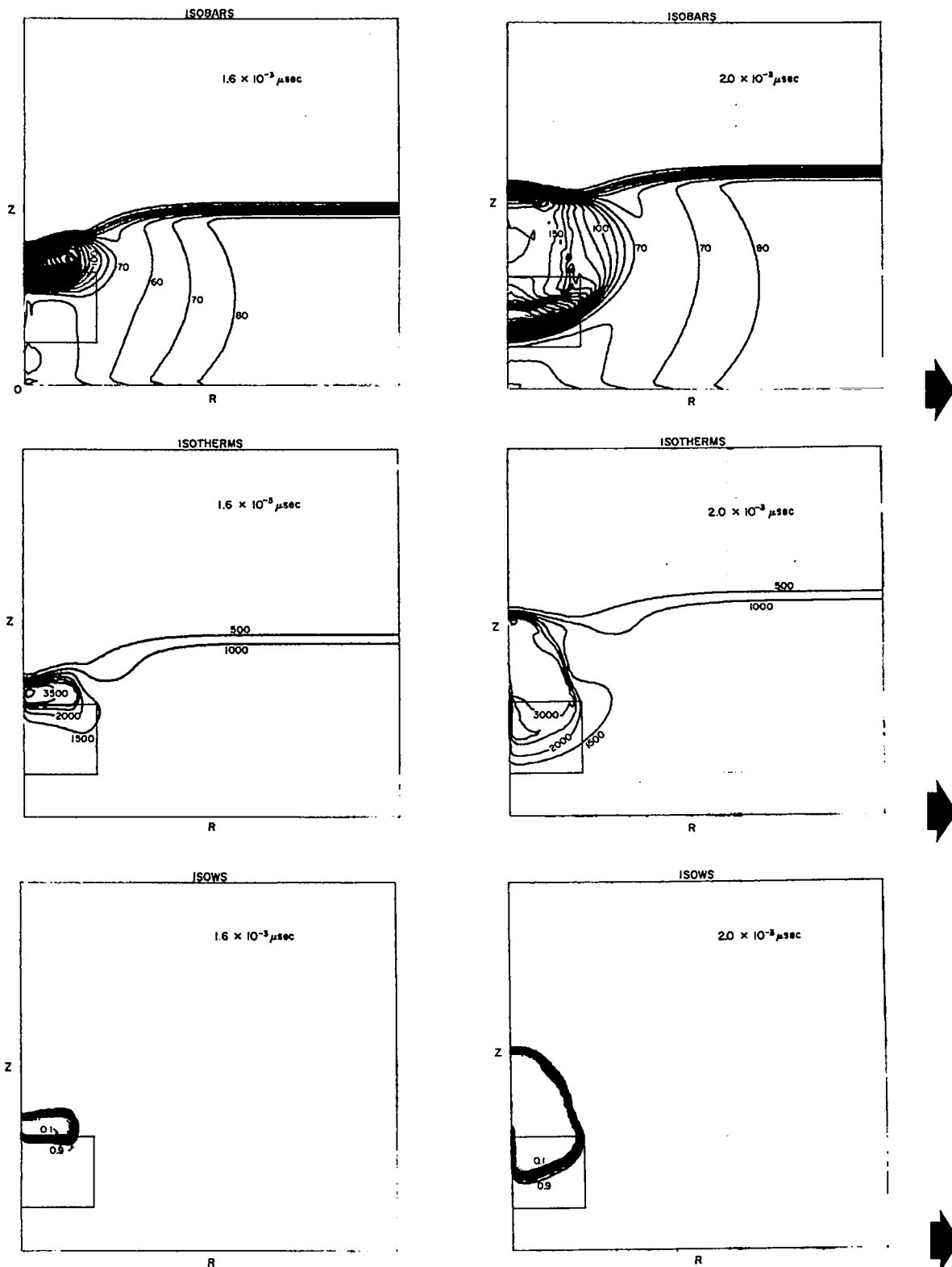
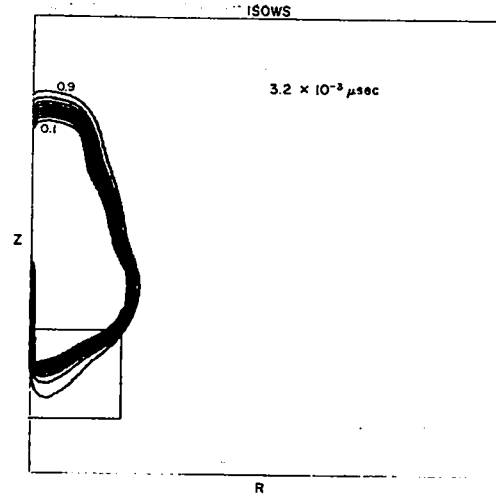
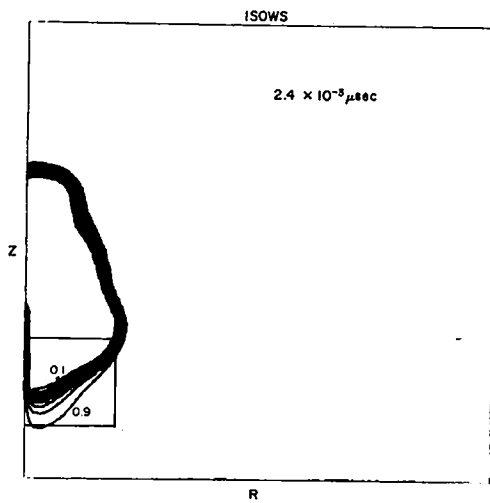
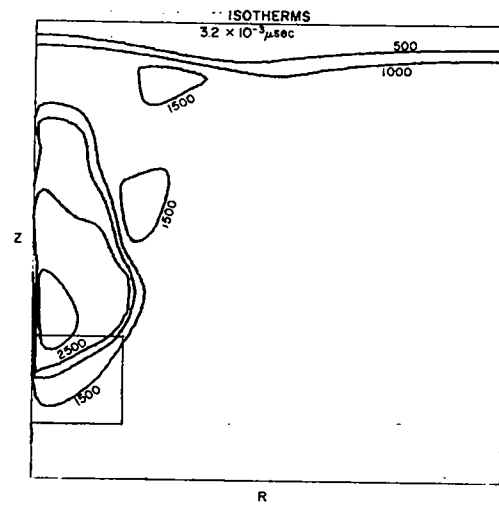
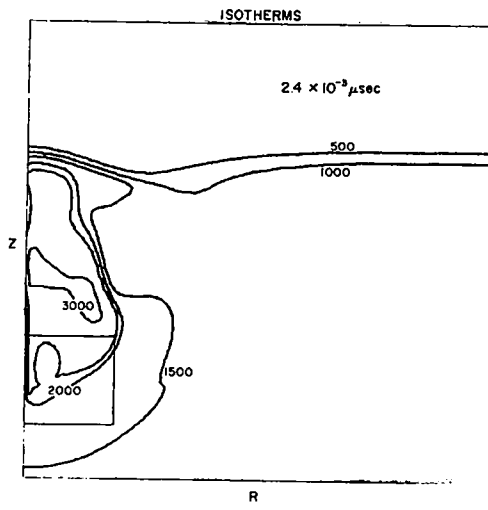
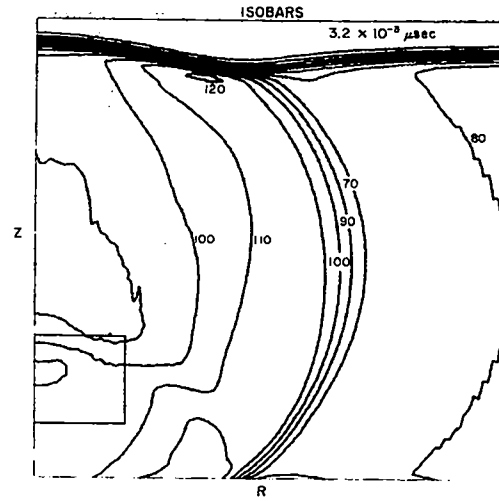
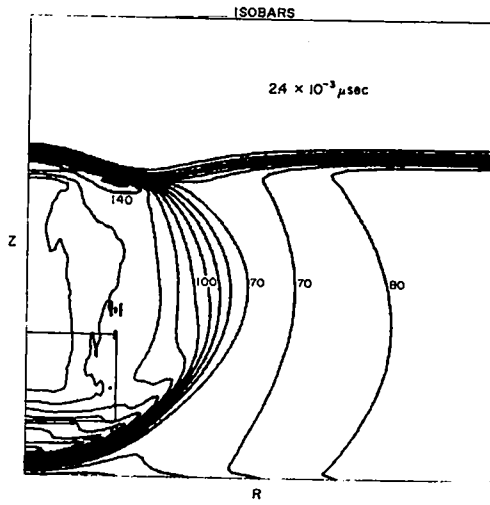

Fig. 9. The computed isobars, isotherms, and isows of an 85-kbar shock interacting with a 3.2×10^{-4} -cm-radius, 3.2×10^{-4} -cm-high, cylindrical void in a 1.6×10^{-3} -cm-radius, 1.6×10^{-3} -cm-high cylinder of nitromethane. Chemical reaction is permitted. The interval between isobars is 10 kbar, that between isotherms is 500° Kelvin, and that between isows is 0.1 where w is mass fraction of undecomposed explosive. The original position of the void is shown.



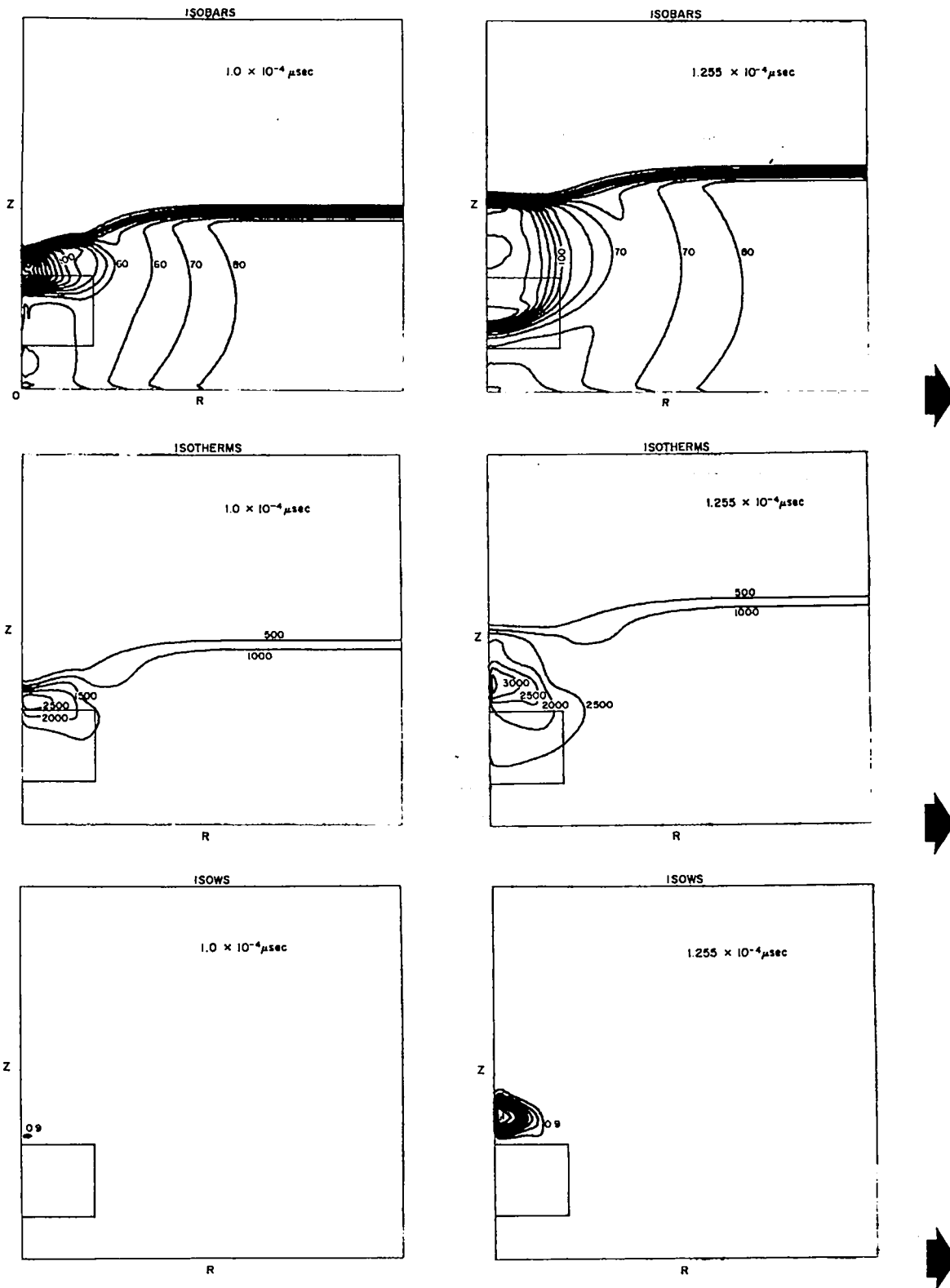
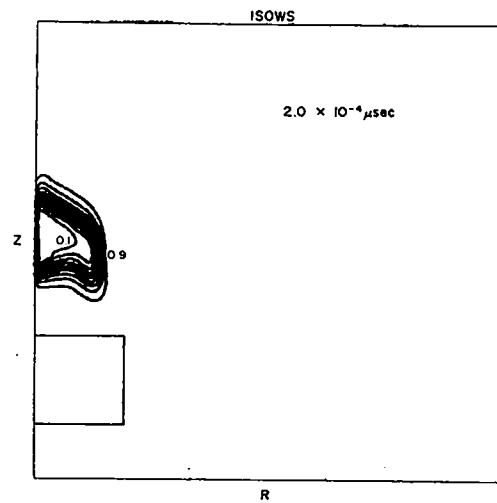
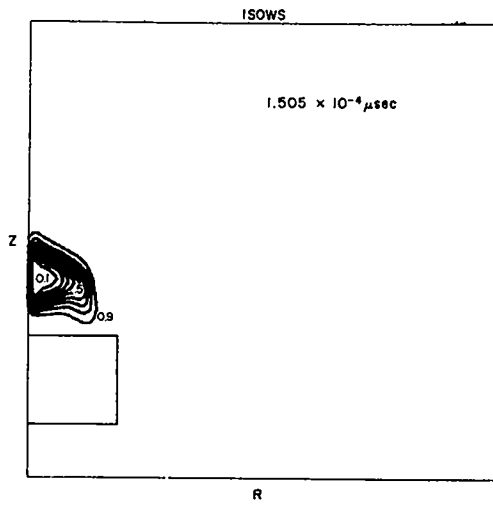
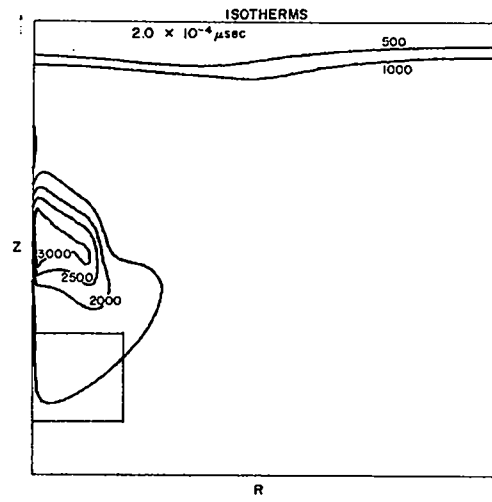
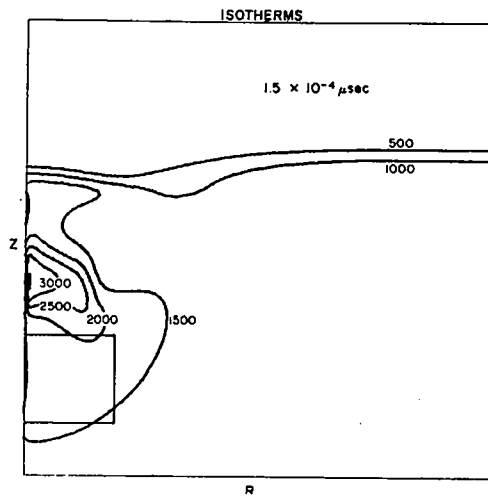
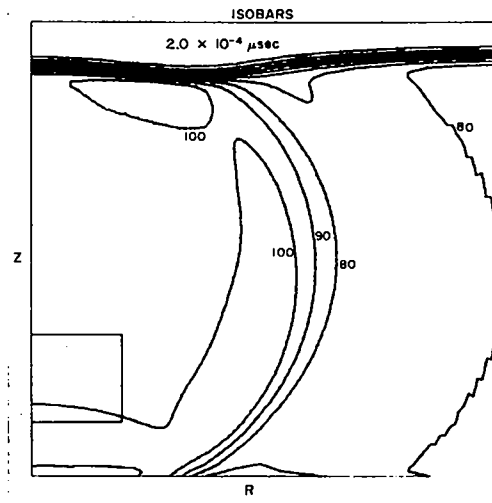
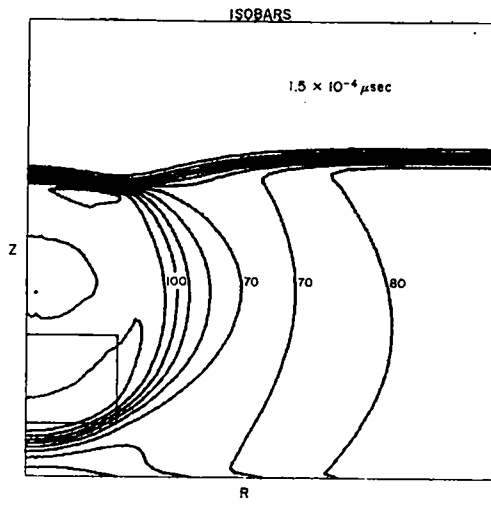

Fig. 10. The computed isobars, isotherms, and isows of an 85-kbar shock interacting with a 2×10^{-5} -cm-high, cylindrical void in a 1×10^{-4} -cm-radius, 1×10^{-4} -cm-high cylinder of nitromethane. Chemical reaction is permitted. The interval between isobars is 10 kbar, that between isotherms is 500° Kelvin, and that between isows is 0.1 where w is mass fraction of undecomposed explosive. The original position of the void is shown.



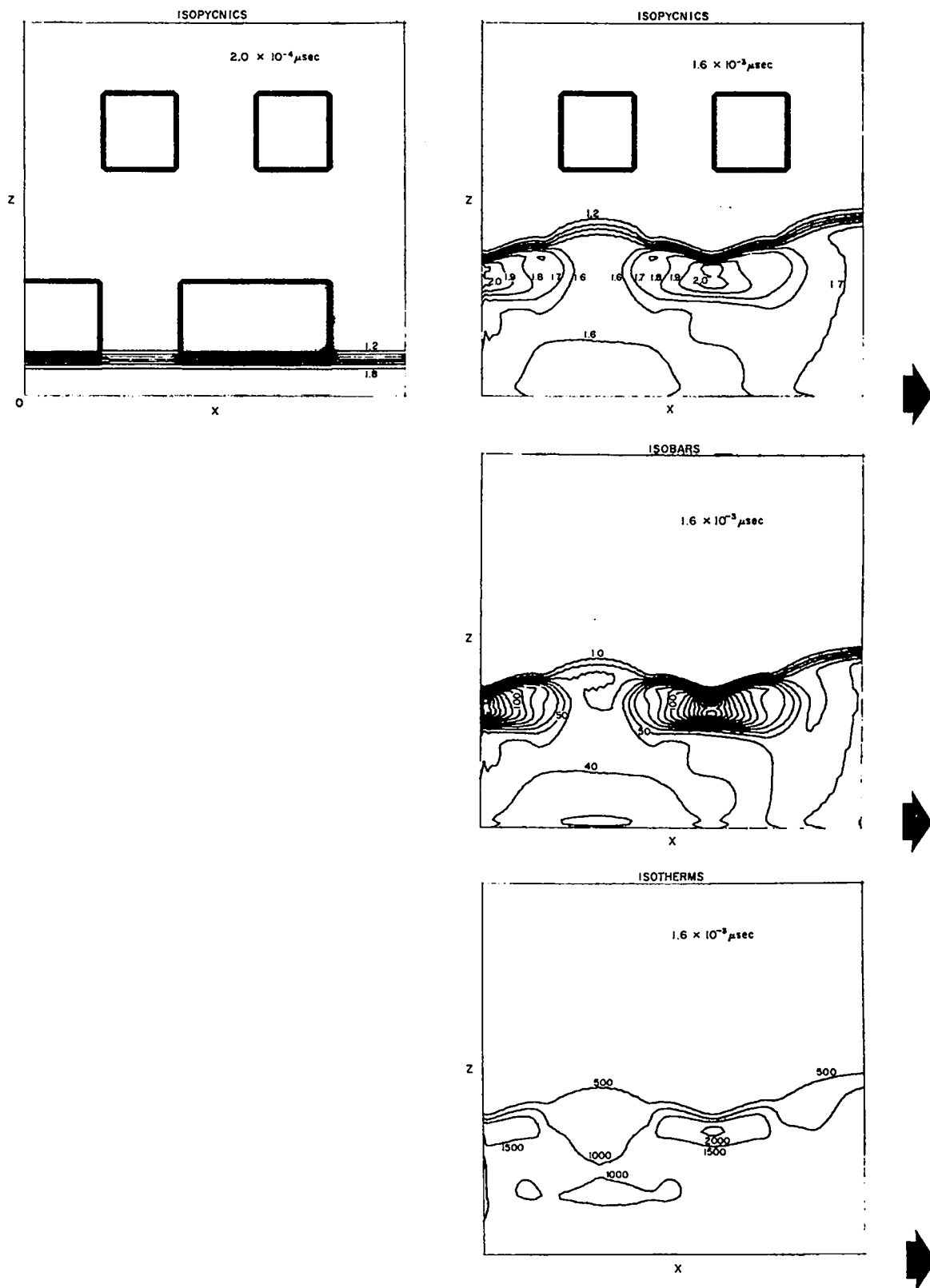
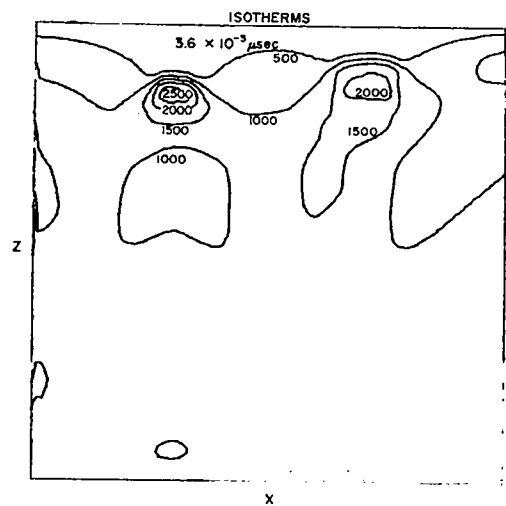
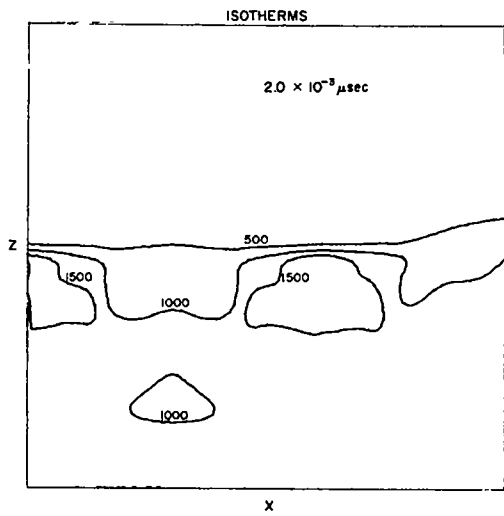
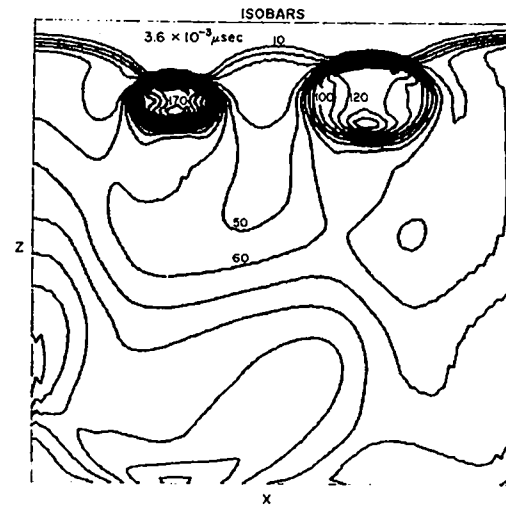
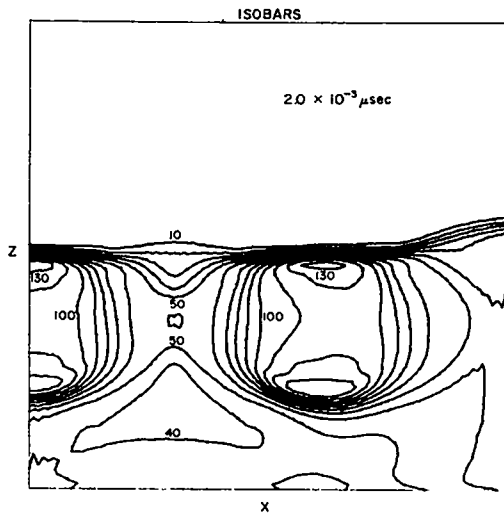
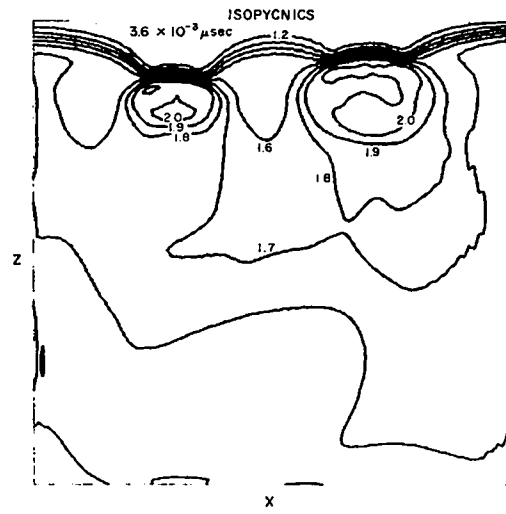
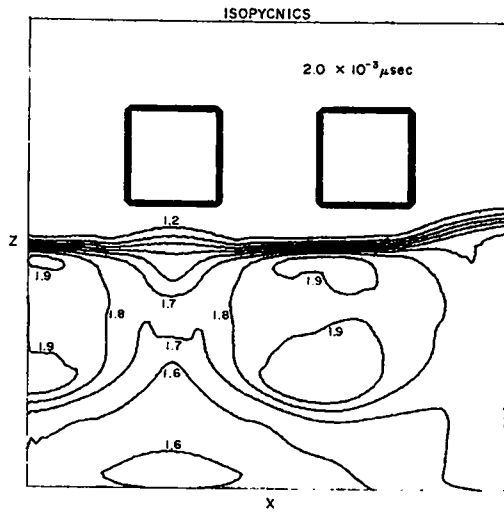

Fig. 11. The interaction of an 85-kbar shock in a 1.6×10^{-3} -cm half-width, 1.6×10^{-3} -cm-high slab of nitromethane with four rectangular holes. Chemical reaction is not permitted. The interval between isopycnics is 0.1 cm/cc, that between isobars is 10 kbar, and that between isotherms is 500° Kelvin. The isopycnics show the hole geometry.



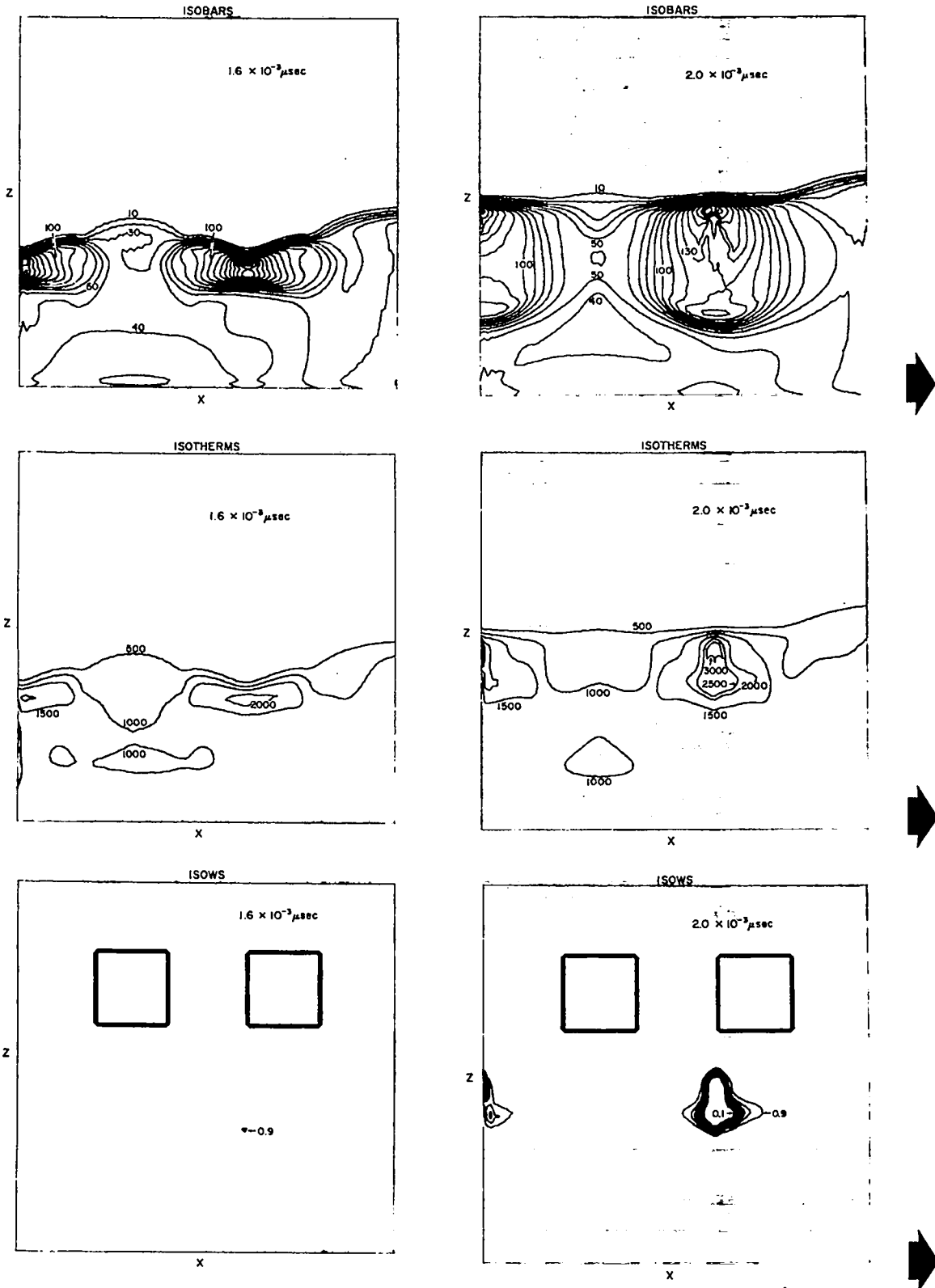

Fig. 12. The interaction of an 85-kbar shock in a slab of nitromethane with four rectangular holes of the same dimensions as those in Fig. 11. Chemical reaction is permitted. The interval between isobars is 10 kbar, that between isotherms is 500° Kelvin, and that between isows is 0.1 where w is the mass fraction of undecomposed explosive.

