

Los Alamos National Laboratory is operated by the University of California for the United States Department of Energy under contract W 7405 ENG 36

Received by OGI

OCT 04 1991

TITLE IMPROVED KrF LASER DESIGN FOR THE LABORATORY MICROFUSION FACILITY

AUTHOR(S) David B. Harris, John A. Sullivan, John H. Pendergrass, Norman A. Kurnit, Evan A. Rose, and John McLeod.

SUBMITTED TO 14th IEEE/NPSS Symposium on Fusion Engineering, San Diego, CA, September 30-October 4, 1991.

DISCLAIMER

This report was prepared as an account of work sponsored by an agency of the United States Government. Neither the United States Government nor any agency thereof, nor any of their employees, makes any warranty, express or implied, or assumes any legal liability or responsibility for the accuracy, completeness, or usefulness of any information, apparatus, product, or process disclosed, or represents that its use would not infringe privately owned rights. Reference herein to any specific commercial product, process, or service by trade name, trademark, manufacturer, or otherwise, does not necessarily constitute or imply its endorsement, recommendation, or favoring by the United States Government or any agency thereof. The views and opinions of authors expressed herein do not necessarily state or reflect those of the United States Government or any agency thereof.

For information on this report, contact the Office of Scientific and Technical Information, Los Alamos National Laboratory, P.O. Box 166, Los Alamos, NM 87545. For sale, contact the Office of Scientific and Technical Information, Los Alamos National Laboratory, P.O. Box 166, Los Alamos, NM 87545.

MASTER



Los Alamos National Laboratory  
Los Alamos, New Mexico 87545



# **IMPROVED KrF LASER DESIGN FOR THE LABORATORY MICROFUSION FACILITY**

**D. B. Harris, J. A. Sullivan, J. H. Pendergrass, N. A. Kurnit, E. A. Rose, and J. McLeod**  
**Los Alamos National Laboratory**  
**Los Alamos, NM 87545**  
**(505) 667-0852**

## **Abstract**

A conceptual design of the KrF laser-driven Laboratory Microfusion Facility (LMF) has been completed. LASNEX calculations predict an indirect-drive target yield of 400 MJ from the 3-MJ, 480-beam driver system. Nine final amplifiers with individual output energy of 412 kJ are used. The total cost of the KrF laser-driven LMF is estimated by an independent cost assessment to be \$921 million in 1992 dollars.

## **Introduction**

The Laboratory Microfusion Facility (LMF) is a single-pulse inertial confinement fusion facility that is intended to (1) develop and demonstrate high target gain, (2) be used to perform advanced weapons physics experiments, (3) perform nuclear weapons effects simulations and vulnerability studies, and (4) advance the understanding of the technological requirements for commercial power and other applications. A Department of Energy-led scoping study [1] of this facility has been conducted over the past five years. The study had two phases. The first phase examined the driver-independent aspects of the LMF, including the utility, development issues, requirements, and staffing and management issues [2]. The second phase examined the driver-dependent aspects of the LMF. Four drivers have been examined for the LMF during phase II: KrF and Nd:glass lasers, and light- and heavy-ion accelerators. Bechtel performed an independent cost assessment of all of the drivers except the heavy-ion accelerator [3]. The general design features and cost of the KrF laser-driven LMF, shown in Fig. 1, will be described here. A full description of the KrF laser-driven LMF conceptual design can be found in reference 4.

LASNEX target design calculations predict that a 3-MJ KrF laser will produce a target yield of 400 MJ. This yield is well within the desired LMF yield range of 200-1000 MJ, although there is considerable uncertainty in all high-gain target calculations. In order to achieve this performance, the 248-nm wavelength KrF laser must deliver pulses with broad bandwidth and high-dynamic-range pulse shapes to the target. The beam quality must also be  $\leq 10$  times diffraction limited (xDL). These performance goals are met by the KrF laser design for the LMF.

The design of the KrF laser driver that meets the LMF requirements has undergone significant improvements during 1991. Key improvements include a larger energy output final-amplifier module that is also more compact than the previous design [5]. The large amplifiers are now located in a single building and are oriented and grouped to save space. The layout of the laser system has also been made more compact and less expensive. A computer aided design code has been used to ensure clearances and space for all beams and components.

The design of the LMF Experiment Area has also been improved. As shown in Fig. 2, the Experiment Area is located underground for safety and to simplify the delivery of beams into the target chamber. The 480 beams are delivered using an indirect drive

illumination geometry. Nuclear Weapons effects simulations and vulnerability studies experimental packages up to 175 m<sup>2</sup> are inserted into the target chamber through an air lock in the top of the conical effects area. This design allows for the several low-yield target shots per day and the one high-yield shot per week desired for the LMF.

### Target Design and Performance

A point design of the LMF target and calculations of the target performance have been completed. The indirect-drive target is calculated to have a yield of 400 MJ when illuminated with 3 MJ of high-dynamic-range pulse shape, broad bandwidth KrF laser energy. Table I lists the specifications for the target calculations.

The LMF target is illuminated with 480 beams that are delivered to target in six cones. Three cones are delivered to target from above, with 20% of the beams coming from a 35° cone, 40% in a 55° cone, and the remaining 40% in a 65° cone. The bottom beams are symmetric with the top beams. Beam phasing, having some beams timed to arrive earlier than others, can be incorporated in a straightforward manner if needed.

Target calculations were performed using the LASNEX design code. The largest uncertainty in the calculation is the target coupling efficiency, defined as the fraction of the laser energy that is deposited on the capsule in the form of x-rays. This fraction is strongly dependent on the dimensions of the capsule and hohlraum. There is a tradeoff between coupling efficiency and capsule symmetry that is currently not well understood, leading to relatively large uncertainties in the achievable coupling efficiency.

Given the uncertainties and assumptions that went into the target calculations, the result was a predicted yield of 400 MJ. Examination of target-performance degradation caused by hydrodynamic instabilities was carried out and was found to be negligible.

### Driver Design

The KrF laser is an attractive candidate for the LMF driver for two reasons. First, the output characteristics of the KrF laser lead to efficient target coupling. The KrF laser operates with a short fundamental wavelength of 248 nm. This short wavelength has been shown to lead to high absorption and x-ray conversion efficiency. Additionally, the short fundamental wavelength allows the KrF laser to operate with the broadest bandwidth that the laser can support (frequency conversion techniques generally only work efficiently if the laser is narrow bandwidth). The combination of short wavelength and broad bandwidth is desirable to increase the threshold for laser-plasma instabilities [5]. The smooth beams from the gaseous KrF lasing mixture also promote efficient target coupling. The KrF laser is also capable of producing the accurate, high-dynamic-range pulse shapes needed for high gain.

The second reason why KrF lasers are an attractive candidate for the LMF is that KrF lasers also project to meet the driver requirements for ICF energy production. The KrF has a gaseous lasing medium that allows repetitive pulsing and has the potential to meet the efficiency requirements. It has long been recognized that it is desirable to have an LMF driver that also meets the driver requirements for ICF energy applications.

A 3 MJ KrF laser has been designed to satisfy the LMF requirements. The design is the culmination of an optimization study that began in 1988. The goals of the study were to:

- design a low cost driver and Experiment Area,
- meet anticipated future safety regulations for all potential hazards associated with the LMF,

- limit technological extrapolations, and
- base the design on existing experimental data as much as possible.

Based on these goals, the design evolved into an angular multiplexed system that employs distributed encoding and three independent amplifier chains fed from a single front end. The complete amplifier staging diagram for one of the three identical laser chains of the LMF driver is shown in Fig.3. The LMF conceptual design includes all of the major components from the front end to the nine ultimate amplifiers [4].

Each of the nine electron-beam pumped ultimate amplifiers generates 412 kJ of laser energy exiting the amplifier window. An amplifier module is shown in Fig. 3 and the design parameters are presented in Table II. The amplifier uses waterline peaking capacitors to shorten the pump pulse rise time of the Marx-bank output to increase the pulsed power efficiency. The output of the peakers is used to supply power in the appropriate pulse shape to the three e-beam diodes on each side of the amplifiers. The short waterline peakers, used instead of the waterline pulse forming lines used on Aurora [6], allow the amplifier to be placed on end as shown in Fig. 3. Placing the ultimate amplifiers vertically allows the nine ultimate and three penultimate amplifiers to be arranged in the compact layout of the industrial-steel amplifier building as shown in Fig. 4 (without the roofs, front walls, and amplifier support structures).

Fig. 5 shows that each laser beam travels back and forth through the Decoder Building eight times. All of the high-energy beam-propagation paths are in helium gas enclosures to minimize losses. Starting at the separation and recollimation array, the beams double-pass the penultimate amplifiers and return to the separation array (paths 1 and 2). The beams are then double-pass the ultimate amplifiers and return to be recollimated at the separation array (paths 3 and 4). Next, the beams travel the length of the decoder building to the first turning array station (path 5). From there, the beams are sent to the decoder mirrors (path 6) and go to the second turning array station (path 7). Finally, the beams are sent through an opening in the center of the separation array and into the Transition Building (path 8).

The Transition and Roundhouse Buildings are shown in Fig. 6. The shaded regions indicate those areas that contain helium. The beams exit the Decoder Building through an opening in the center of the separation arrays to enter the Transition Building. The beams then reflected as shown before being directed into the Roundhouse Building. The entrance to the Roundhouse is through an aperture in the shielding wall to reduce neutron streaming to the rest of the LMF. After the beams enter the Roundhouse, they are reflected downwards into the underground Experiment Area.

### Experiment Area Design

The Experiment Area contains the target chamber and associated support equipment, target and beam diagnostics, and the optics that transport and focus the beams onto the target. As shown in Fig. 2, the spherical target chamber of 5-m inside radius is supported by a cylindrical 1 m thick concrete shield wall just outside of the 1.5 m-thick close-in borated water shield of the chamber. A conical shaped chamber at the top of the spherical chamber is used to expose objects with cross sections up to 175 m<sup>2</sup> for nuclear weapons effects simulations and vulnerability studies. The modular borated water shield above the effects chamber can be drained and removed in small sections to permit convenient insertion and recovery of large experimental packages.

The 480 laser beams enter the Experiment Area through its ceiling, which is the floor of the Roundhouse Building. Most of the beams (384) require one flat turning mirror, a diagnostic beam splitter, a lens, a flat vacuum window, and a blast shield in

the Experiment Area for transport and focus of the beams on the target. The remaining 96 beams require one additional flat turning mirror. In the Experiment Area, the beams are transported in individual helium-filled beam tubes to maintain an air environment within this area to simplify maintenance and operations. A shielded diagnostic access area surrounds the target chamber to allow access shortly after target shots. Convenient access to all levels is provided by elevators located just outside the walls of the Experiment Area.

Many target chamber concepts have been described for the LMF. [7-12] Some innovations were introduced for the KrF laser-driven LMF. However, because of the geometric complexity, the multiplicity of phenomena involved, and the fundamental physics uncertainties, the many concepts all have numerous questions that remain to be answered before a target-chamber concept can be confidently designed.

Experiment Area equipment comprises much more than just the target chamber. In addition to the chamber vacuum systems, several fluid systems will be interfaced with the target chamber to control the chamber environment. They include liquid helium and liquid nitrogen, cooling water and chilled water, special gas cooling and heat transfer systems, inert-gas systems, and contaminated gas and liquid cleanup systems.

To support target operations, several additional systems will be required. The appropriate environment must be provided for targets while they are transported from target fabrication to the target chamber. The targets must be inserted into the chamber and accurately positioned and oriented. Pre-shot diagnostic measurements may be needed to monitor the state of the targets inside the chamber until they are illuminated by the driver. The yields and emission spectra of targets will need to be measured to characterize the driver energy deposition, its conversion to x rays and transport to the fuel capsule, the fuel capsule implosion, and the thermonuclear burn. The driver beam energies, balance, uniformity, pulse shape, and bandwidth will also need to be measured. Additional systems will be needed to support applications experiments.

Some of the target-operations equipment will be located within the chamber. Equipment such as the target supports, cryogenic coolant lines, and some instrumentation may be located within a few centimeters to a few tens of centimeters of the target and be completely vaporized by the target emissions. Some equipment may be located within a range of distances outside the zone of complete vaporization out to ~1 m, in which, in addition to some vaporization, it may be melted or fragmented by the intense deposition of energy released by the target. Material located at this distance from the target can produce energetic drops or solid projectiles that can, upon impact, damage surfaces of other equipment and the chamber walls.

Still other equipment, including the chamber walls, blast shields, and experimental equipment, may be located sufficiently far from the target microexplosion so that only surface ablation is a concern. The deposition of ablated material onto critical surfaces, such as optical and diagnostic surfaces, must be prevented. The use of unfueled dud target experiments may be desired for the examination of target performance. However, the reduction of the available energy to only that delivered by the driver may actually increase the production of projectiles above what would be produced in high yield experiments.

The target chamber itself is not just a simple pressure/vacuum vessel but may also include first wall protection systems, a separate first wall structure, environment control systems, optics protection equipment, chamber support structures, and

shielding. The principal design and physics uncertainties for all LMF target chambers include:

- the effects of the impulse generated from the ablation of exposed chamber surfaces;
- the history of the pressure loading of the chamber walls by ablated material as the vapor is generated, expands, stagnates at surfaces, is traversed by shock waves, and condenses;
- thermal stresses and shock waves and their reflections, damping, concentrations, and vibration modes that may arise in complex three-dimensional structures and equipment;
- the numbers of projectiles of various sizes and speeds that are generated, the interactions of such projectiles with exposed optics and the chamber first wall, and the requirements and performance of equipment required to protect against these projectiles;
- the vulnerabilities of materials to and changes in material properties resulting from cumulative neutron and gamma irradiation;
- the potential transport of ablated material and deposition onto exposed surfaces;
- the adsorption onto and embedding into exposed surfaces of tritium and activated materials and the decontamination of such surfaces; and
- the neutron activation of target chamber materials and materials throughout the Experiment Area.

The 15-m distance of the first optical surfaces from the target is projected to necessitate the use of special equipment to protect them at the calculated LMF yield of 400 MJ. The chamber first wall may also require protective measures to assure its survival. Several concepts have been proposed for such protection [7-12]. The most promising concepts for chamber protection include the use of thin, renewable layers of frost or room-temperature porous solids to reduce the first-wall peak stresses and ablation. A promising concept for protection of optics is the injection of high-atomic-number gases just prior to firing the laser combined with fast closing mechanical shutters to protect against projectiles and deposition of ablated materials.

### Environment, Safety, and Health

Concern for the environment and the safety and health of workers and the public has been a driving force in the design of the KrF laser-driven LMF. The LMF is projected to not have any significant environmental impacts beyond those resulting from the construction of any large facility. Additionally, the LMF projects to have only minimal emissions during normal operations. However, the laser amplifiers use fluorine gas and operate with high voltages. Large enclosures containing helium are used throughout the facility for beam propagation. In the Experiment Area, large numbers of energetic neutrons are emitted by targets, and activation of exposed materials is a concern.

The amplifiers can be operated safely using standard operating procedures and safety systems developed for high voltages and hazardous gases. Detectors and interlocks will be needed to ensure that it is safe to enter enclosures that normally contain helium for maintenance. Monitors for leakage into ordinary LMF working areas will also be needed. Self-contained breathing equipment will be used with accepted safety procedures to enter the helium enclosures for short periods for minor maintenance and repairs.

We have designed the LMF to have the Experiment Area buildings cope with natural disasters such as flooding and storms. However, the target chamber itself must

also meet additional safety goals at acceptable cost and risk while achieving the desired performance. In addition to maintaining its structural integrity for the largest credible yields, the target chamber must be designed to survive the maximum-expected earthquake accelerations for its location. Additionally, the chamber must not be activated excessively and must be shielded to reduce activation throughout the rest of the Experiment Area.

The principal radiation-safety requirements for facilities such as the LMF are well known. There is no doubt that these goals can be met. The principal issues arise in connection with the tradeoffs involving capital, operating and maintenance costs, and the experiment rates and types that can be achieved in the LMF. The design of the target chamber and its shielding can have a significant impact on these tradeoffs.

In the Experiment Area, low-activation materials will be used to reduce the waiting period before personnel can reenter the Experiment Area after a high-yield shot. Such materials include special low-activation aluminum alloys, high-purity borated concrete, and very-low-activation reinforced polymeric materials and other composites. Similarly, special shielding and radiation-streaming control measures will also be used as required to limit personnel exposure.

### Cost

Bechtel served as an independent cost contractor for Phase II of the DOE-led Laboratory Microfusion Capability Scoping Study. Among other things, their responsibility was to produce cost estimates for three different LMF concepts.

Table II lists an overview of the Bechtel-generated cost estimate for the KrF laser-driven LMF. Details can be found in Reference 3. The total estimated cost, including contingency, escalation, and project office, is \$921 million in 1992 dollars.

### Summary

The conceptual design of a 3-MJ KrF laser-driven LMF has been completed as part of the DOE-led Laboratory Microfusion Capability Scoping Study. The KrF laser uses nine final amplifiers, each generating 412 kJ. The 480 beams are transmitted through helium to reduce losses and are delivered to target through a series of buildings designed for radiation safety. The Experiment Area is located underground for cost and safety reasons. LASNEX calculates that the 3-MJ KrF laser-driven LMF will have an indirect-drive target yield of 400 MJ. The total estimated cost of the LMF in 1992 dollars is \$921 million.

### Acknowledgments

The authors would like to thank Leonard Goldman, Gary McAllister, Jerry McDaniel, and Anvo Agur of the Bechtel Corporation. Their contributions to the KrF laser-driven LMF design included suggestions for significant improvements to the laser system and Experiment Area architecture as well as the estimate of the cost. We would also like to thank the many Los Alamos personnel that contributed to the design of the LMF. We also express our appreciation to Ian Smith and his co-workers at Pulse Sciences Inc. for their work on the design of the pulsed power and diode of the large amplifier modules. Our appreciation also goes to David Bixler, who led this study for the U.S. DOE for the past five years.

## References

1. D. N. Bixler and S. A. Goldstein, "A Laboratory Microfusion Capability for the U.S. ICF Program," *Fusion Technology*, **19**, 646 (1991).
2. D. N. Bixler et al., "Laboratory Microfusion Capability Study: Phase I Summary," DOE/DP-0069, U.S. Department of Energy (1989).
3. L. Goldman et al., "Laboratory Microfusion Capability Cost Study: Capital Cost Report," Bechtel Corporation report in preparation (August 21, 1991).
4. D. B. Harris et al., "KrF Laser-Driven Laboratory Microfusion Facility Design Concept Report," Los Alamos National Laboratory report LA-UR-91-2915 (August 1, 1991).
5. D. B. Harris et al., "KrF Laser Path to High Gain ICF Laboratory Microfusion Facility," *FUSION TECHNOLOGY* 1990, p. 1282, B. E. Keen, M. Huguet, and R. Hemsworth, editors, Elsevier Science Publishers B.V. (1991).
6. L. A. Rosocha et al., "Aurora Multikilojoule KrF Laser System Prototype for Inertial Confinement Fusion," *Fusion Technology*, **11**, 497 (1987).
7. J. H. Pitts, J. G. Woodworth, and M. Tabak, "Preventing Vaporization and Destructive Shock Waves in ICF Target-Chamber First Walls," *Fusion Technology*, **15**, 563 (1989).
8. C. D. Orth, "Frost as the First Wall for the ICF Laboratory Microfusion Facility," *Fusion Technology*, **15**, 571 (1989).
9. D. G. Nilson and J. G. Woodworth, "Final Optic Protection Designs for ICF Containment Chambers," *Fusion Technology*, **15**, 578 (1989).
10. M. T. Tobin and M. S. Singh, "Neutronics Analysis of the Laboratory Microfusion Facility," *Fusion Technology*, **15**, 583 (1989).
11. D. Slaughter, "Overview of the ICF 1000 MJ Experiment Chamber Design," *Fusion Technology*, **15**, 590 (1989).
12. M. J. Monsler and W. R. Meier, "A Carbon-Carpet First Wall for the Laboratory Microfusion Facility," *Fusion Technology*, **15**, 595 (1989).



**Table I**  
**LMF Target Specifications**

<u>Parameter</u>	<u>Value</u>
Driver energy on target	3 MJ
Number of beams	480
Illumination geometry	2-sided indirect
Number of beam cones per side	3
Beam cone angles	35°, 55°, 65°
Fraction of beams per cone	20%, 40%, 40%
Beam quality	≤10 xDL
F number	100
Minimum spot size (95% of energy)	450 μm
Bandwidth	0.5%
Pulse duration (peak power portion)	6.5 ns
Pulse duration (total)	53 ns
Pulse dynamic range	200:1
Calculated capsule yield (LASNEX)	400 MJ

**Table II**  
**Ultimate Amplifier Specifications**

<b>Parameter</b>	<b>Value</b>
Amplifier width	160 cm
Amplifier height	480 cm
Amplifier pumped length	500 cm
Operating pressure	1 atm
Pump rate	190 kw/cm <sup>3</sup>
Pump duration (flat portion)	1080 ns
Krypton fraction	80.00%
Argon fraction	19.47%
Fluorine fraction	0.53%
Loss factor (to shadowing, baffles, etc)	17%
Back mirror reflectivity	96%
Output window reflectance (per surface)	1.5%
Output window internal transmission	98%
Initial small signal gain	2.61%/cm
Initial nonsaturable loss	0.39%/cm
Initial saturation intensity	1.49 MW/cm <sup>2</sup>
Amplifier output energy	412 kJ

**Table III**  
**KrF Laser-Driven LMF Cost Estimate**

<b>WBS</b>	<b>Item</b>	<b>Total Estimate (1992 M\$)</b>
1.0	Project Office	125.11
2.0	Site Improvements & Utilities	6.16
3.0	Buildings and Support Facilities	160.69
4.0	Driver	296.29
5.0	Experiment Area Equipment	59.00
6.0	Support Systems	19.80
	Escalation to 1992 dollars	68.37
	Contingency (25.2%)	<u>185.32</u>
<b>TOTAL LMF COST (millions)</b>		<b>\$921</b>

## Figure Captions

- Fig. 1.** Schematic of the KrF laser-driven LMF. The final two amplifier gain stages in the system are located in the Large-Amplifier Building. The Decoder Building contains the input and output arrays for the amplifiers and the decoder for the angularly multiplexed laser system. The Transition Building provides the turns of the laser beams and the shielding necessary to reduce neutron streaming up the laser. The Roundhouse Building provides shielding and turns the beams downwards through the 480 holes in the floor into the underground Experiment Area (not shown).
- Fig. 2.** The underground Experiment Area for the LMF.
- Fig.3** The amplifier staging concept for the 3-MJ LMF uses three parallel arms after the front end. The amplifiers are shown shaded, and the interstage transport efficiencies are shown in circles.
- Fig. 4.** The LMF amplifier module uses Marx banks and waterline peakers to power the electron beam that pumps the KrF laser.
- Fig. 5.** Nine ultimate-gain-stage amplifiers and three penultimate amplifiers are located in a single building. Removable grid floors are used for maintenance and removal of the amplifiers.
- Fig. 6.** Layout of a single bay in the Decoder Building showing the beam paths.
- Fig. 7.** After recollimation and decoding in the Decoder Building, the beams are directed through the Transition Building to the semicircular mirror arrays in the Roundhouse, which directs the beams down into the Experiment Area.

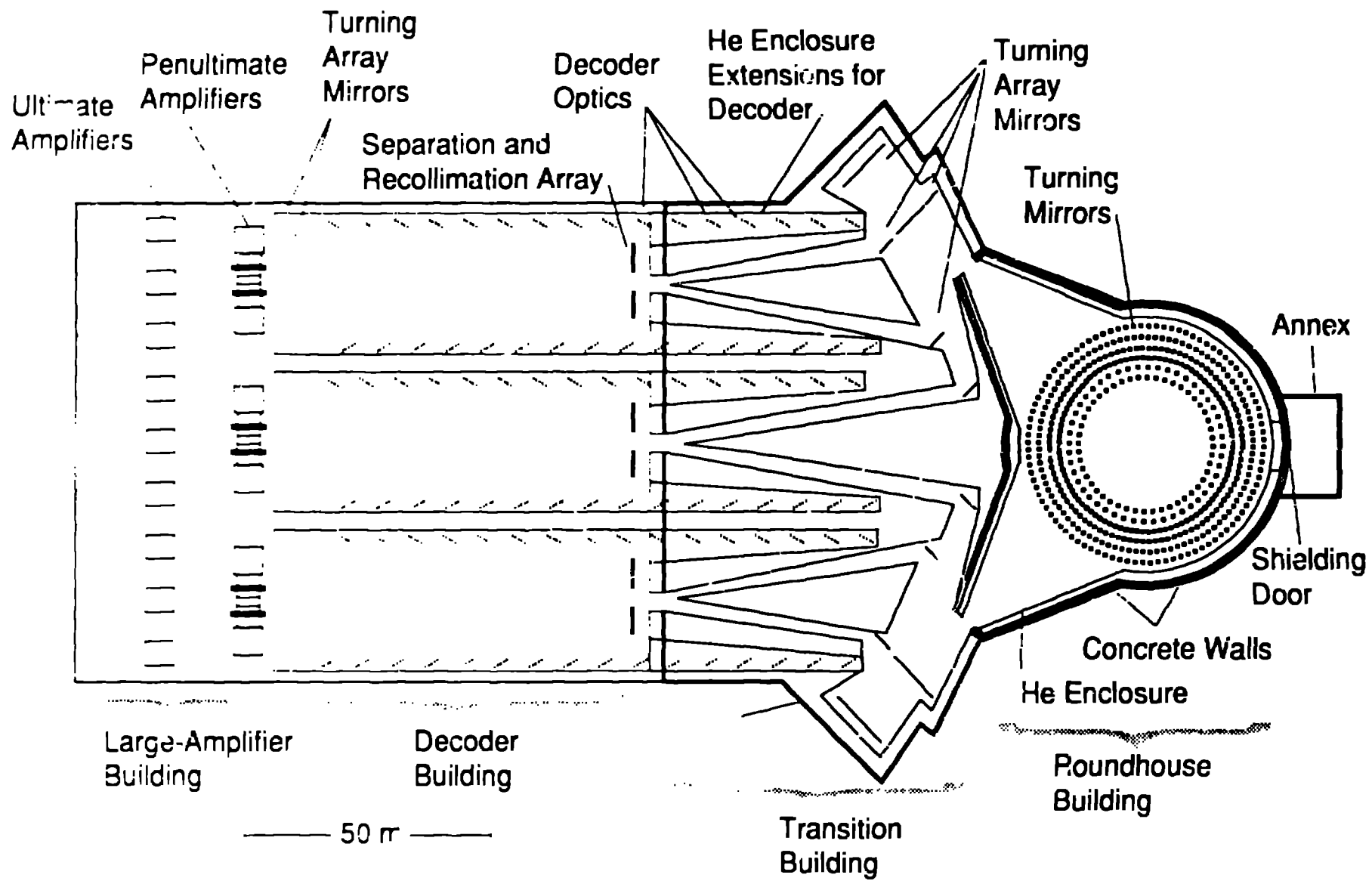

Fig. 1

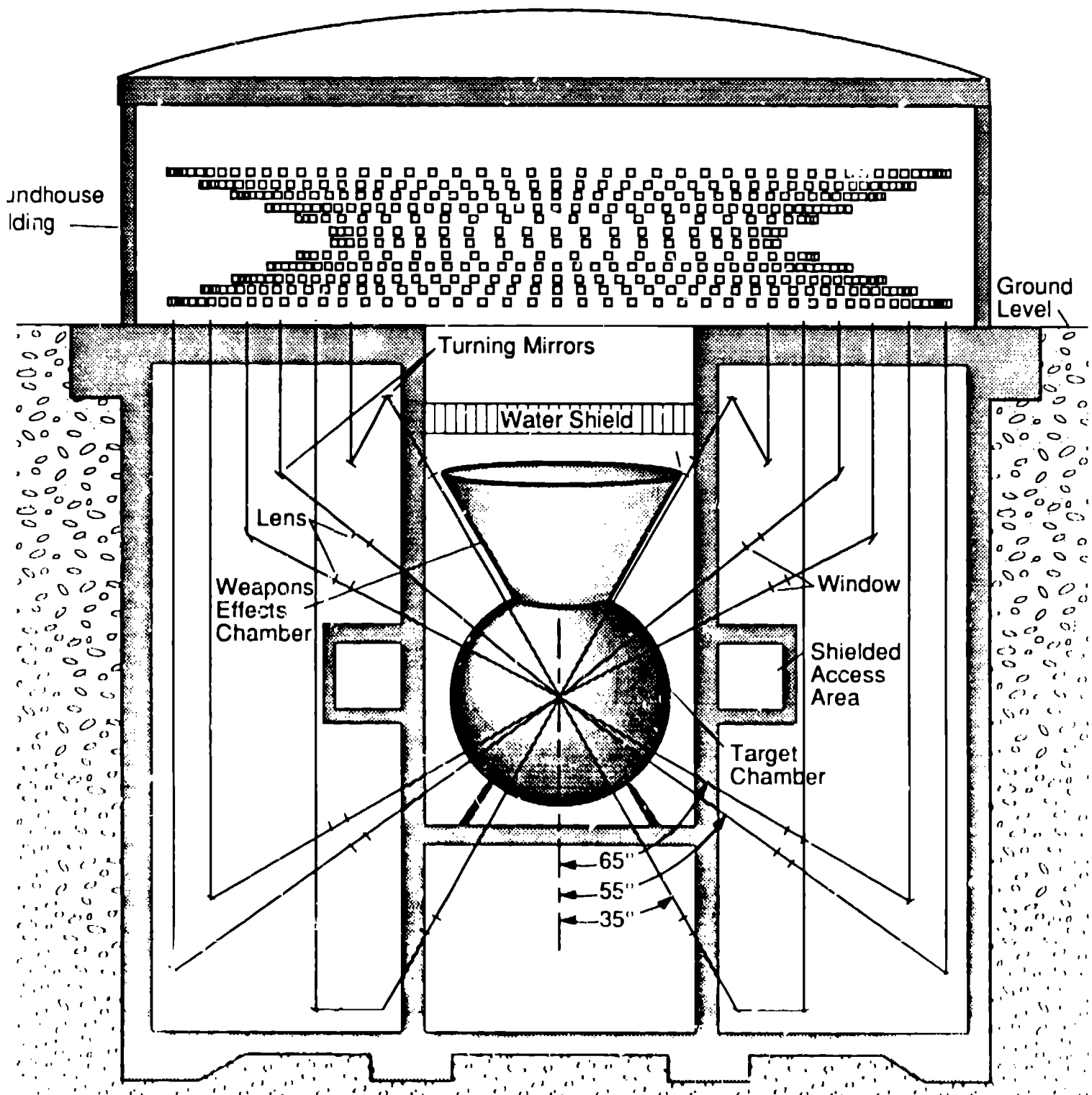

Fig. 9

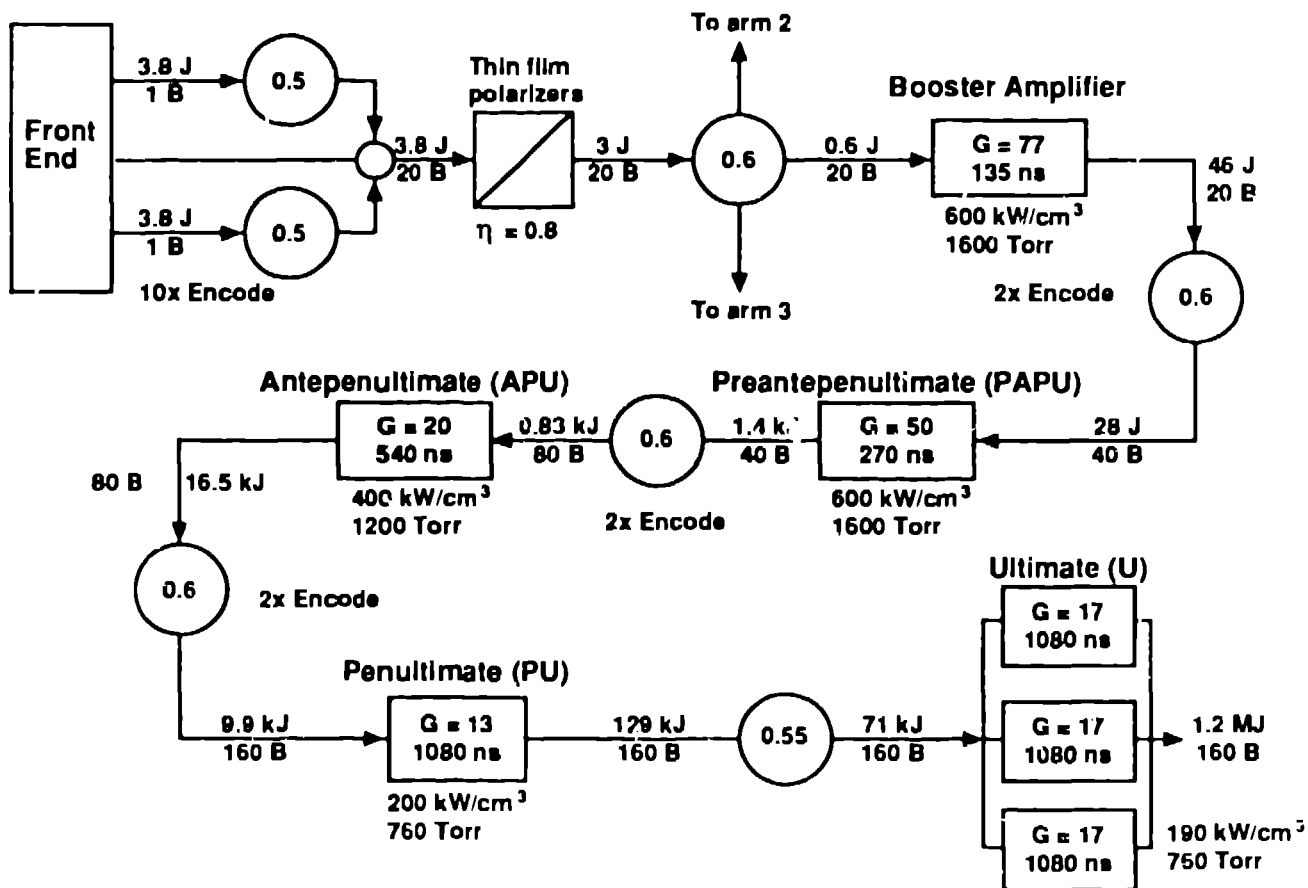

Fig. 3

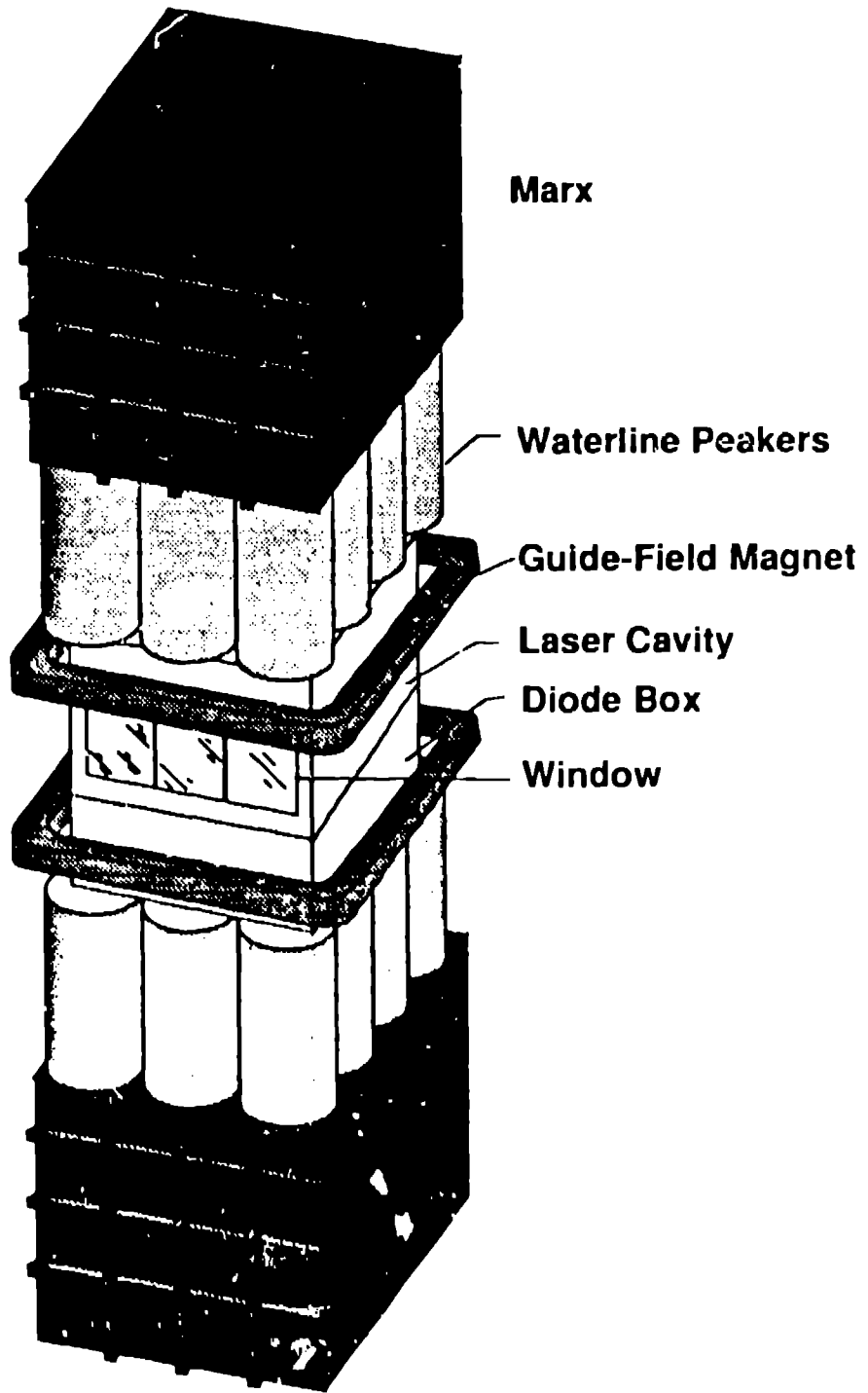

Fig 4



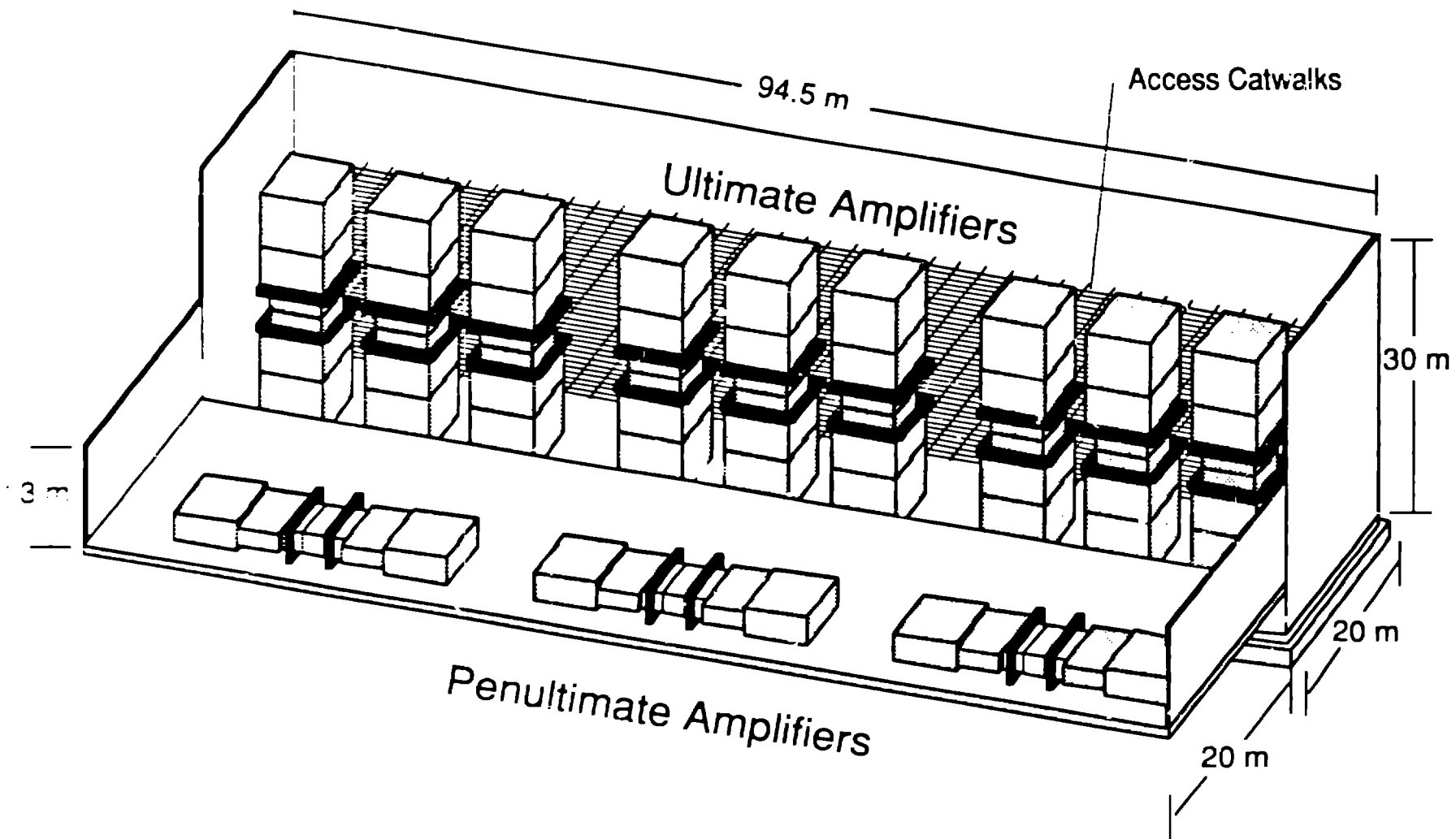

Fig. 5

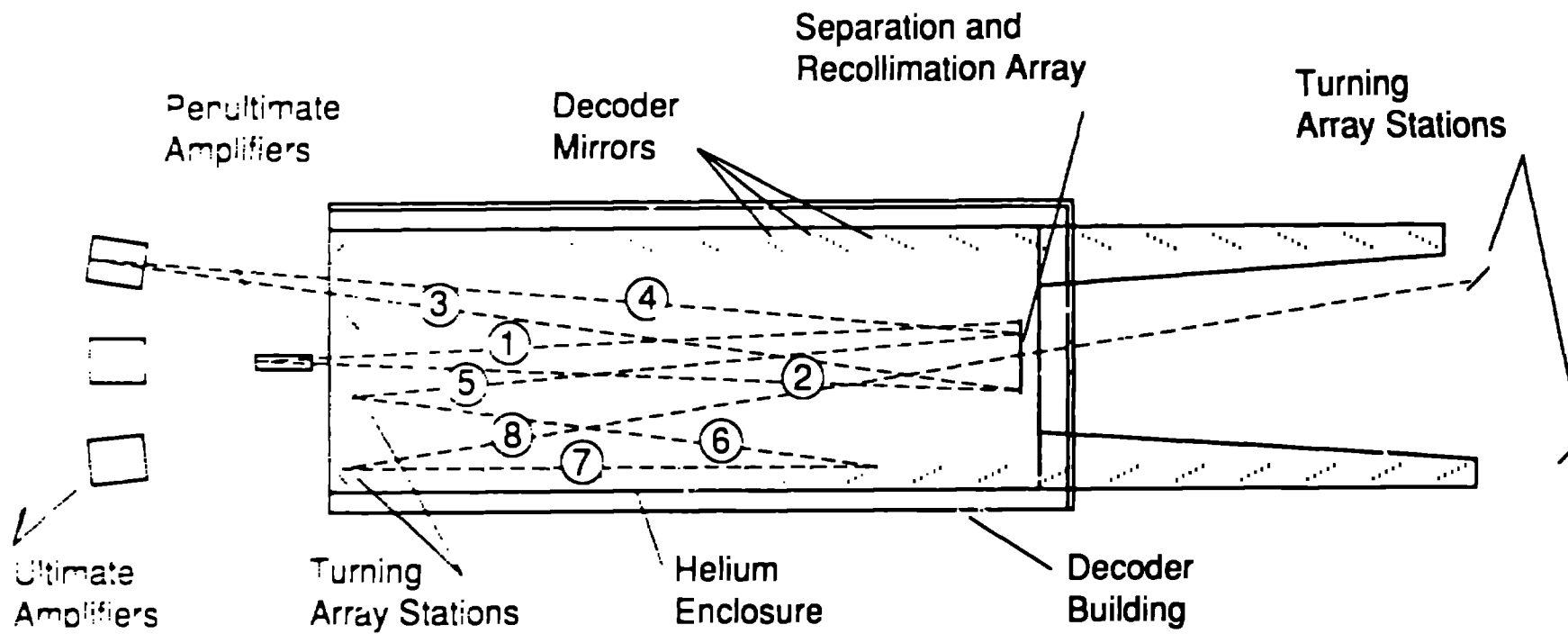

Fig. 6

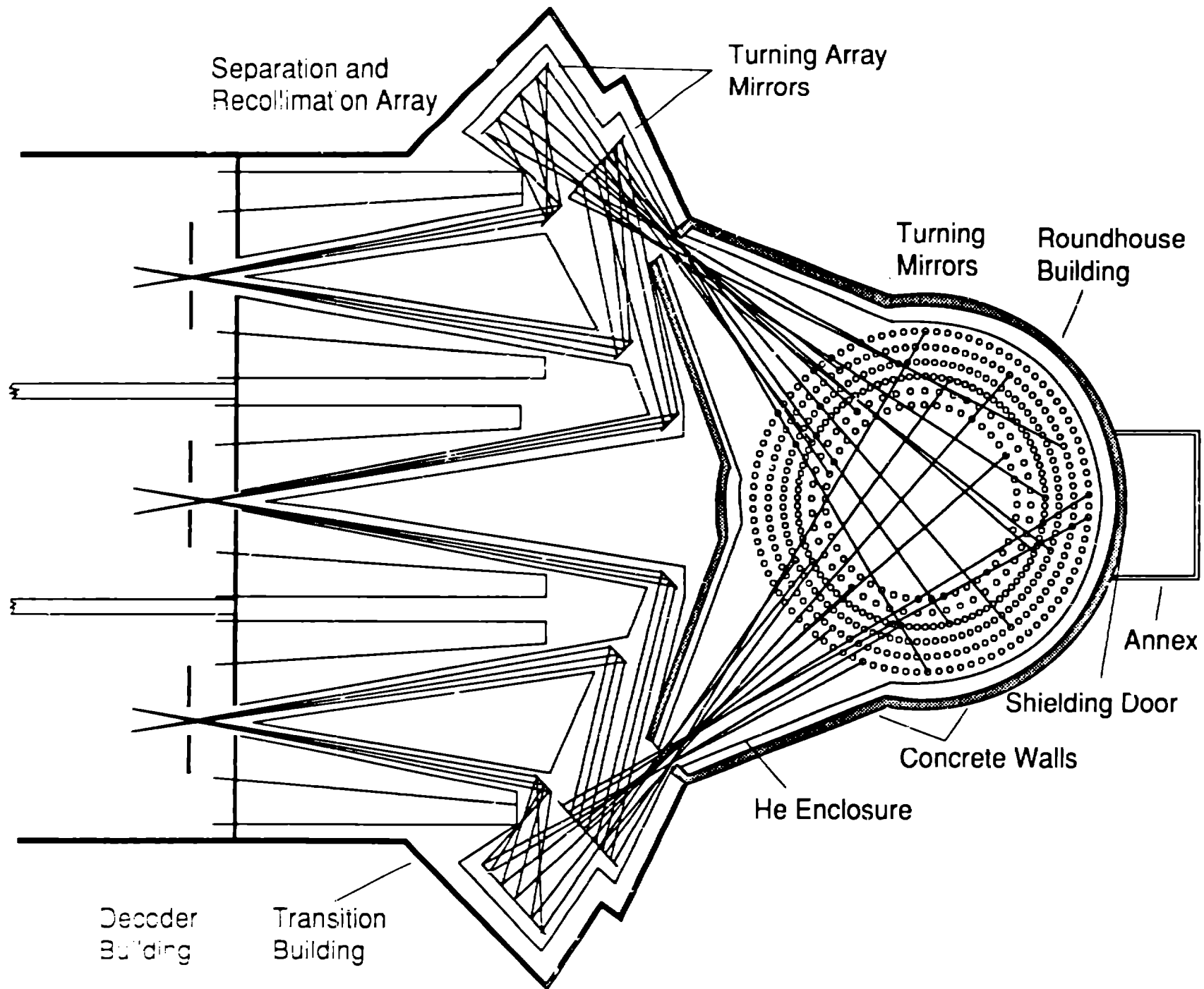

Fig. 7

# **IMPROVED KrF LASER DESIGN FOR THE LABORATORY MICROFUSION FACILITY**

**D. B. Harris, J. A. Sullivan, J. H. Pendergrass,  
N. A. Kurnit, E. A. Rose, and J. McLeod**

**Los Alamos National Laboratory  
Los Alamos, New Mexico**

**14th IEEE Symposium on Fusion Engineering  
September 30 - October 3, 1991  
San Diego, California**

# An updated conceptual design for the KrF laser-driven Laboratory Microfusion Facility has been completed

---

- **Laser design improvements include:**
  - *improved laser performance calculations*
  - *larger amplifiers with more compact pulsed power*
  - *more compact amplifier stacking arrangement*
  - *more compact decoder*
- **Experiment Area improvements include:**
  - *better neutron shielding*
  - *better control of neutron streaming*
  - *improved access to target chamber after experiments*
  - *improved target performance calculations*
- **A computer-aided design code was utilized:**
  - *to ensure clearances and space for all beams, optics, amplifiers, and other LMF components*
- **Bechtel performed an independent cost estimate**

## **Outline of presentation**

---

- **Brief review of previous LMF design**
- **Description of new LMF design**
  - *overview*
  - *large amplifiers and their performance*
  - *amplifier stacking arrangement*
  - *revised decoder layout*
  - *transport of beams to target*
  - *experiment area*
  - *target design calculation*
- **Bechtel cost estimate**

# The Laboratory Microfusion Facility applications define the facility requirements

---

## Applications:

- *Develop high-gain targets for energy and defense missions*
- *Perform weapons effects, vulnerability and survivability experiments*
- *Perform weapons physics experiments*

## LMF Requirements:

- *Yield of 200 - 1000 MJ*
- *2 shots per day*
- *1 high-yield shot per week*
- *Experiment area suitable for performing the above applications*

**The LMF requirements then define the driver requirements**

Original LMF design used four laser bays  
and an above-ground experiment area

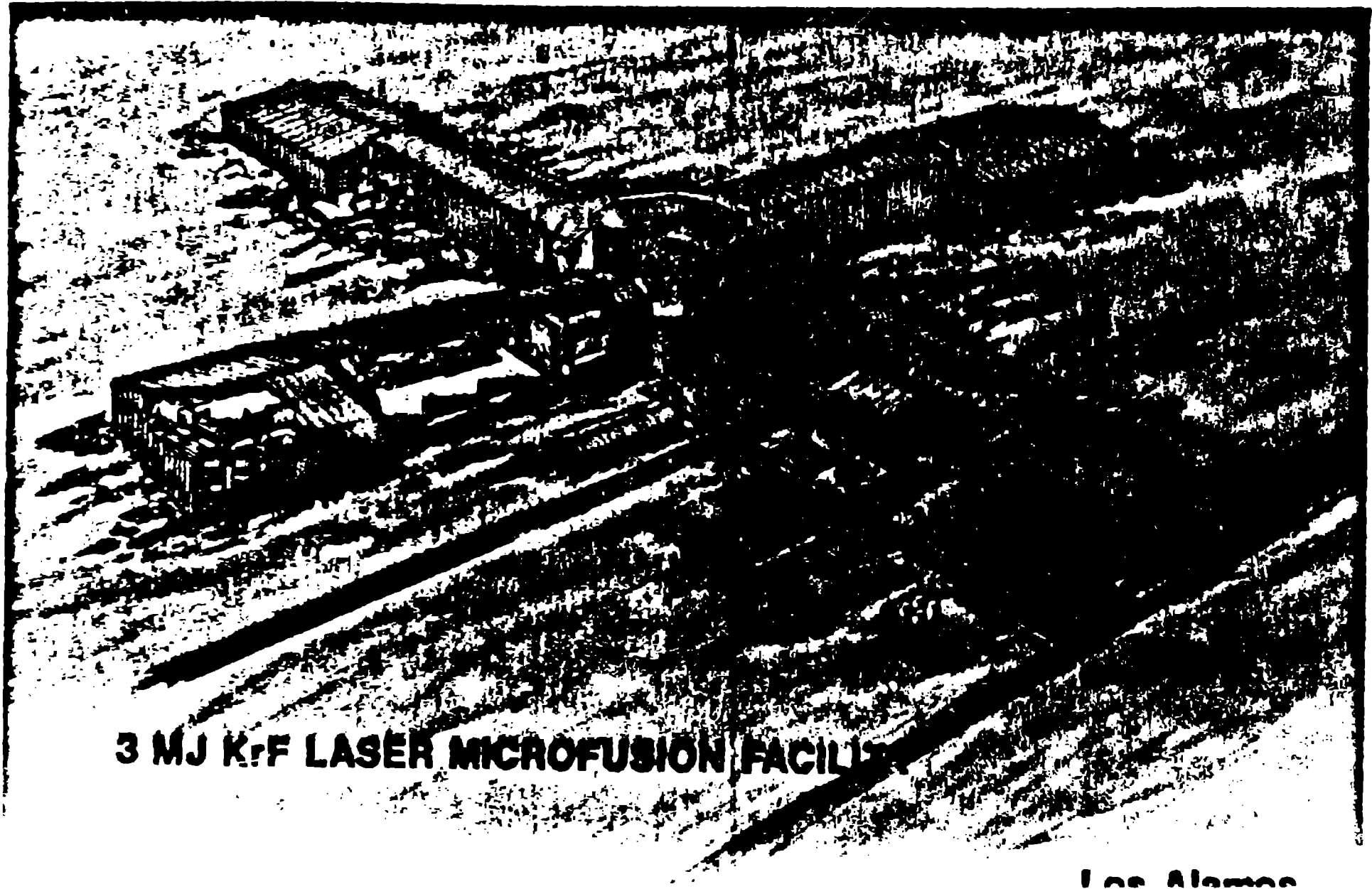

**3 MJ Krf LASER MICROFUSION FACILITY**

Los Alamos

5/20/75



# The improved LMF design is more compact and lower cost than the original version

---

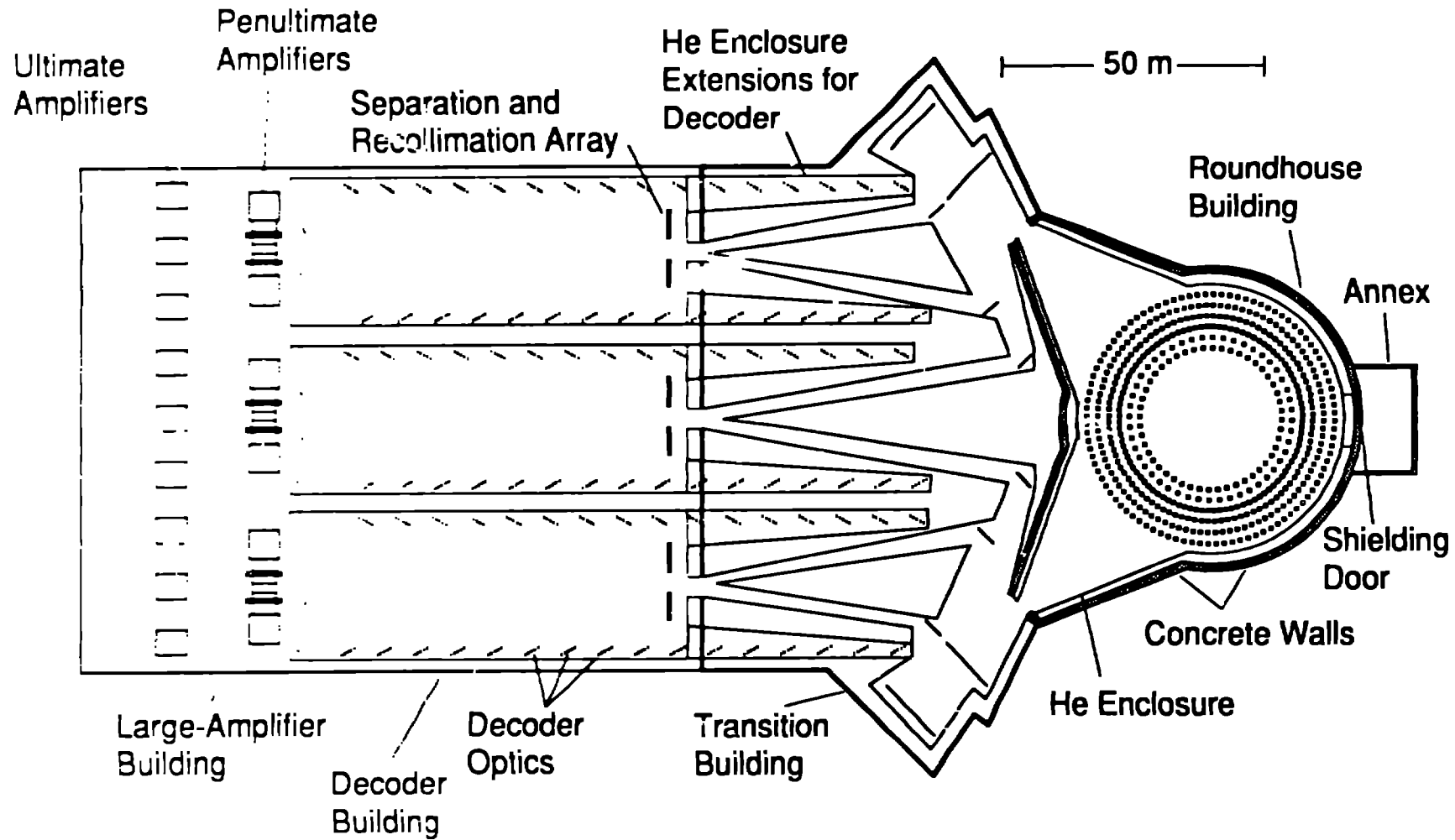

Los Alamos

**LMF amplifiers use segmented pulsed power, diodes, and windows. Calculated output is 400 kJ.**

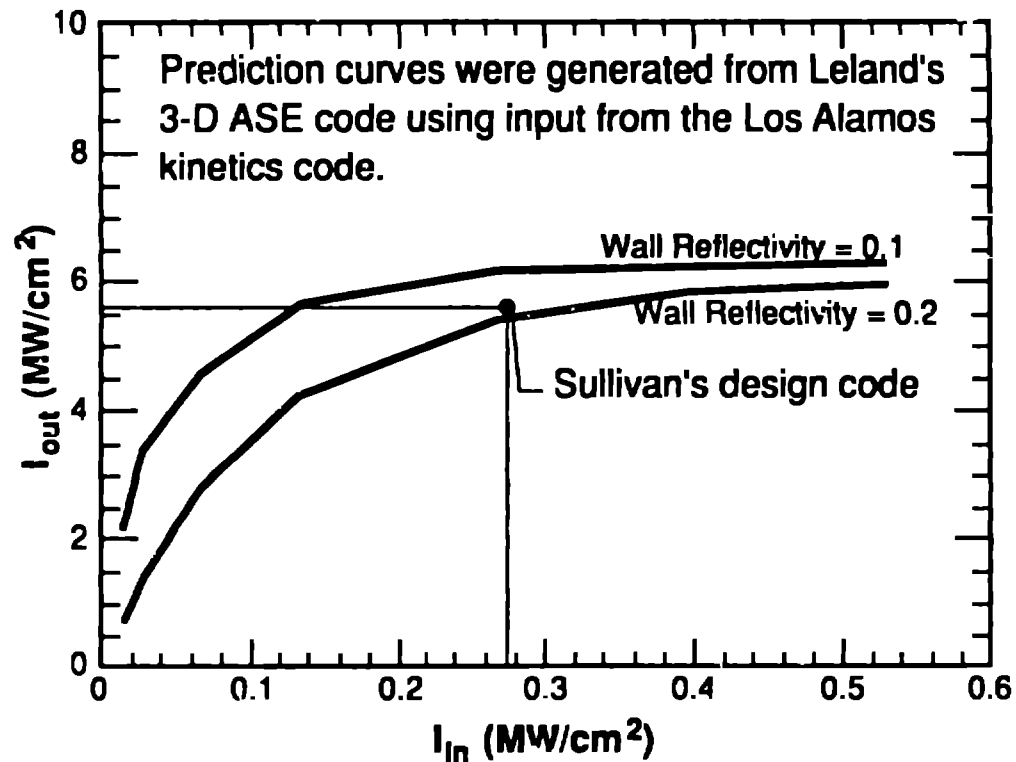
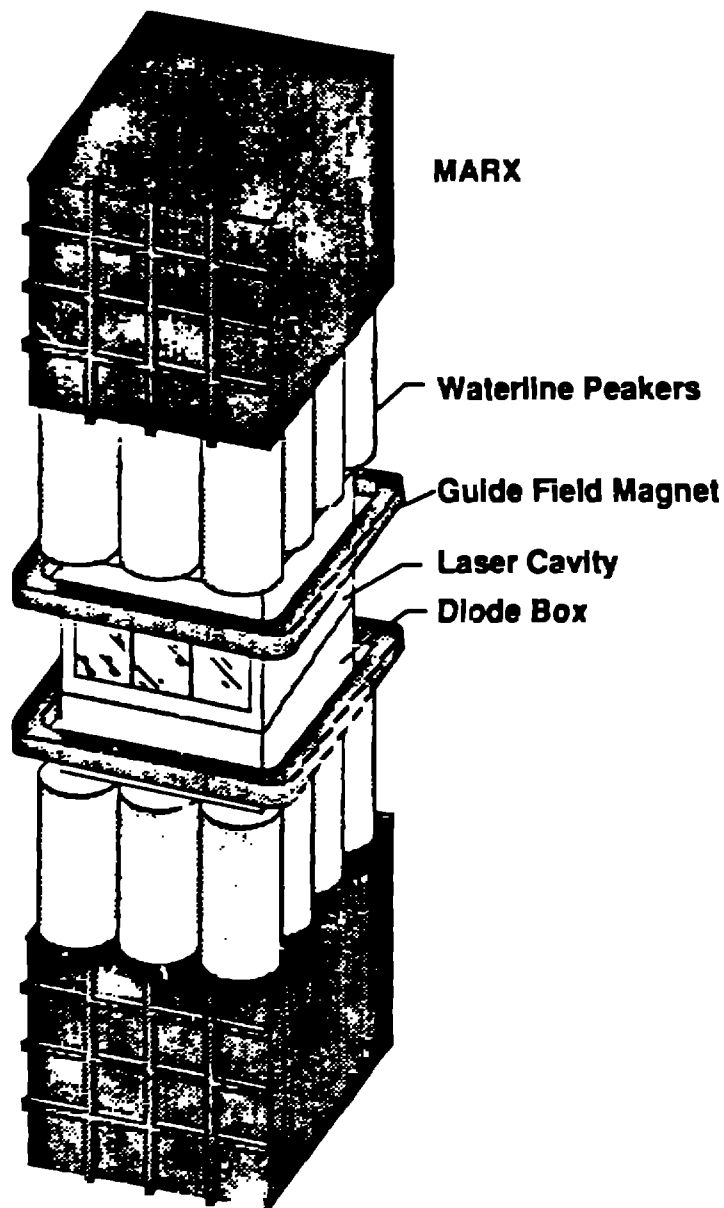

**Amplifier parameters:**

Pump dimensions	1.6 m x 4.8 m x 5.0
Pump rate	190 kW/cm <sup>3</sup>
Pump duration	1080 ns

**Los Alamos**

**Nine final amplifiers and three penultimate-gain-stage amplifiers are arranged in a compact architecture and located in a common building**

---

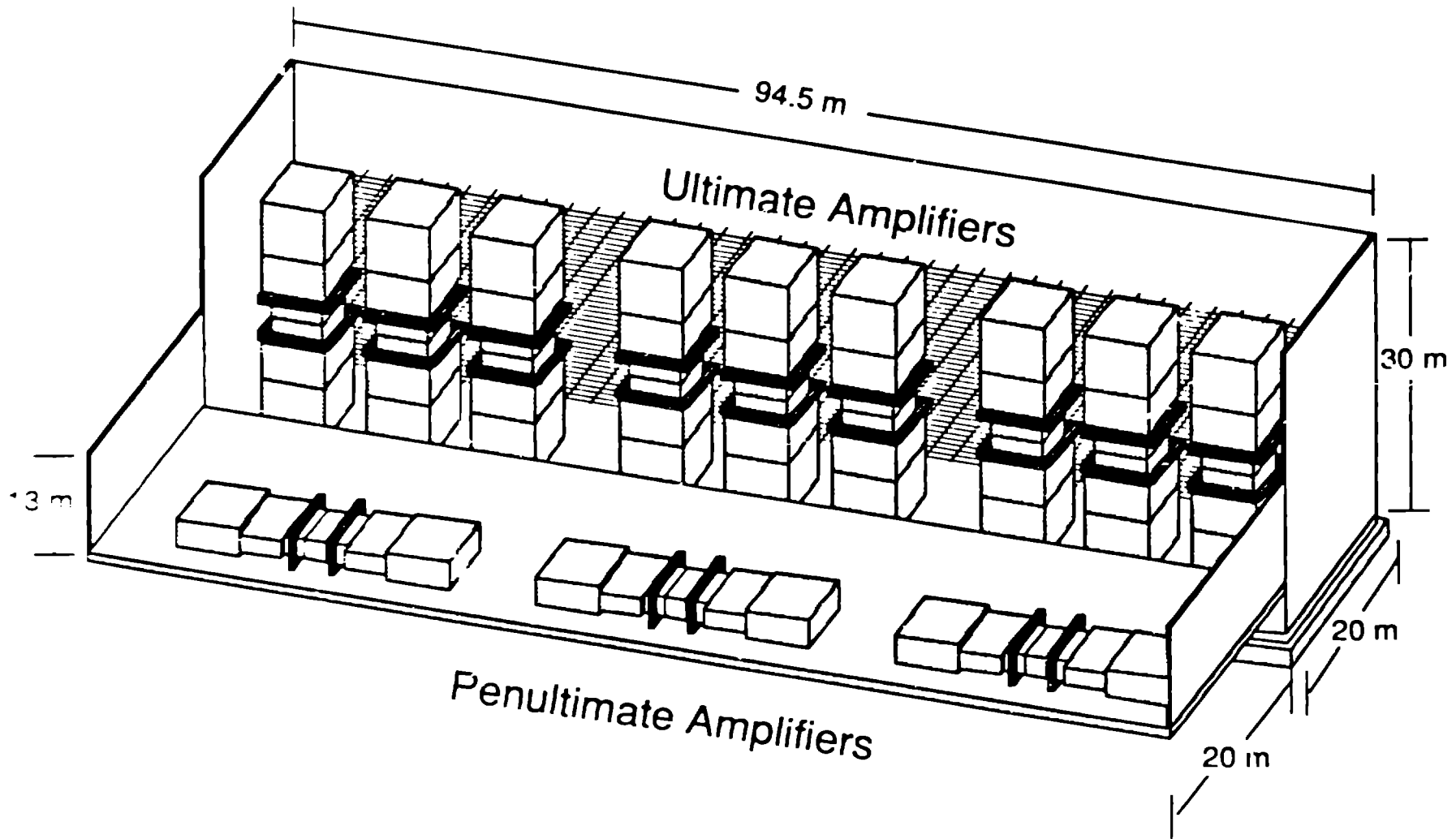

Los Alamos

# Folding the light paths in the decoder makes the Decoder Building more compact

---

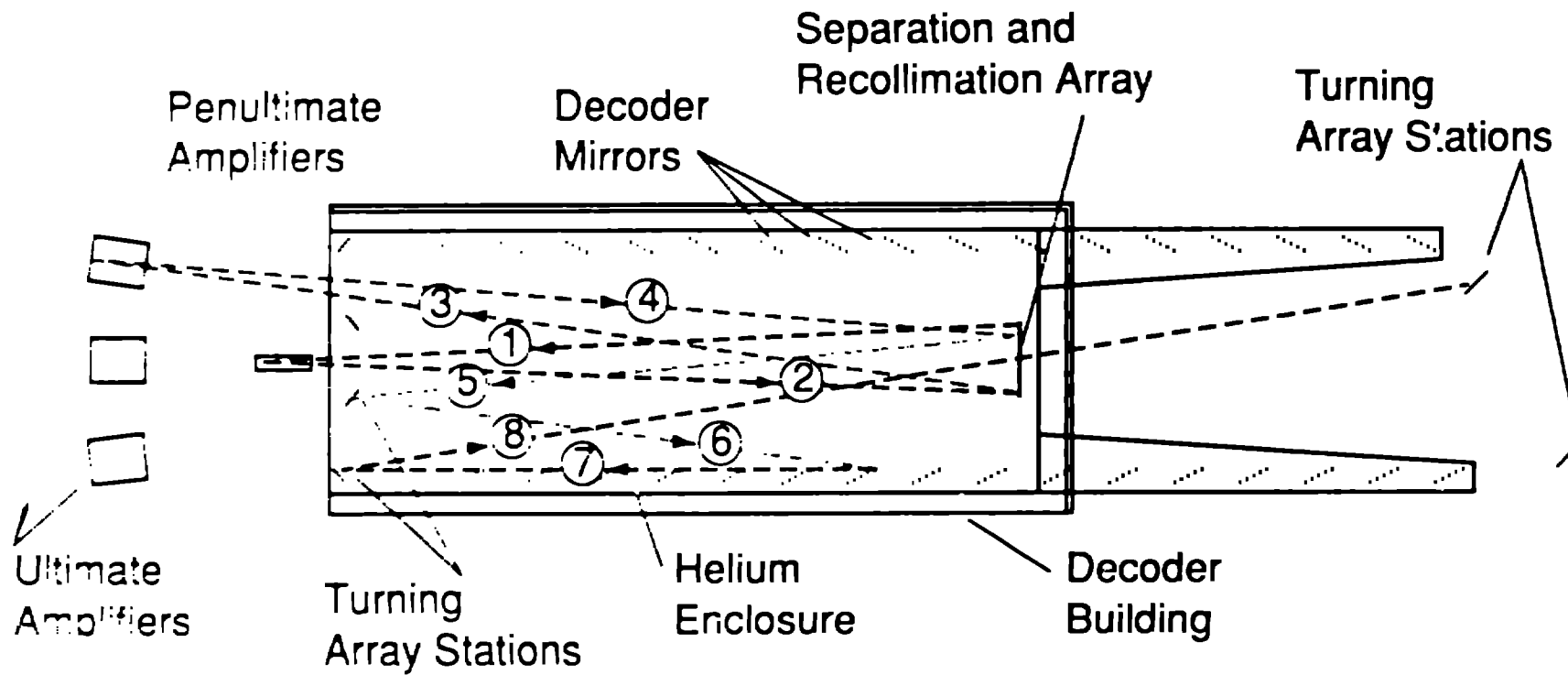

Plan view shows the three-bay decoder layout and the Large-Amplifier Building. Side view shows the stepped decoder optics increasing in height as it extends into the Transition Building.

---

Plan View

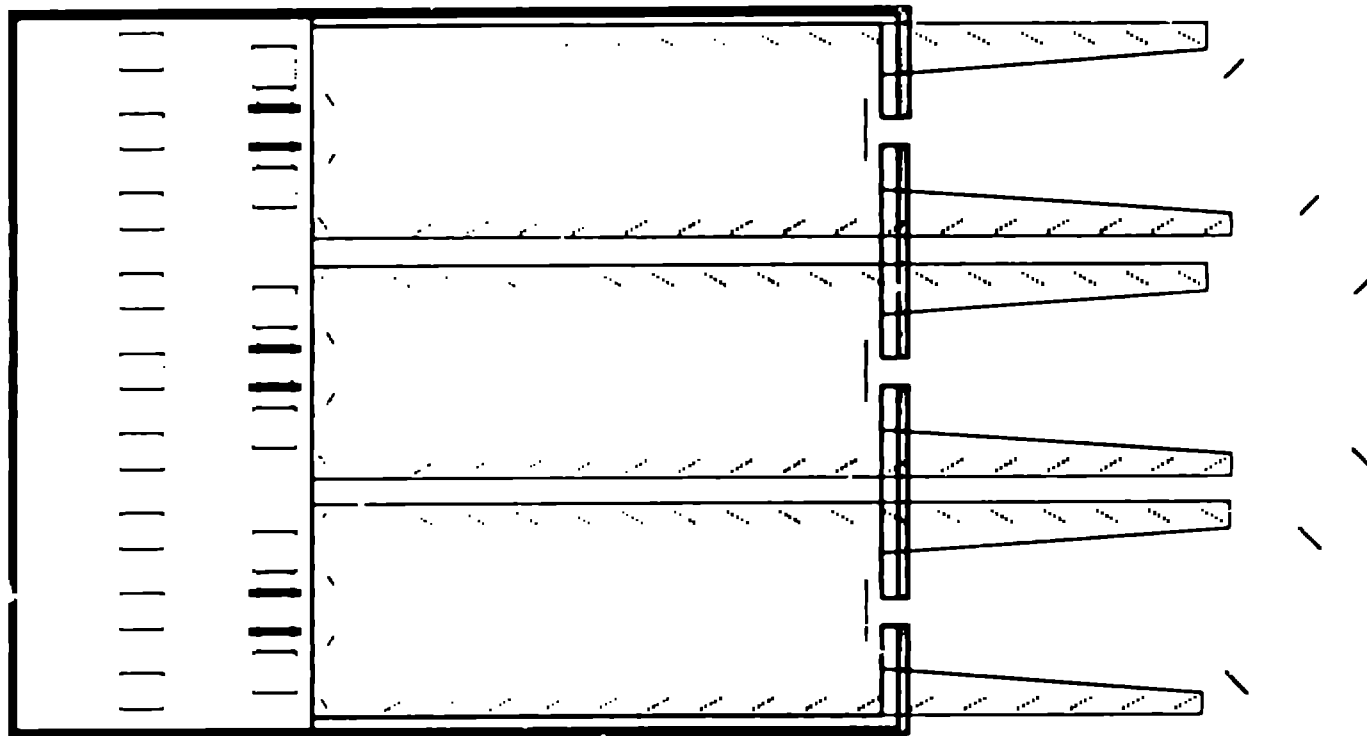

Side View

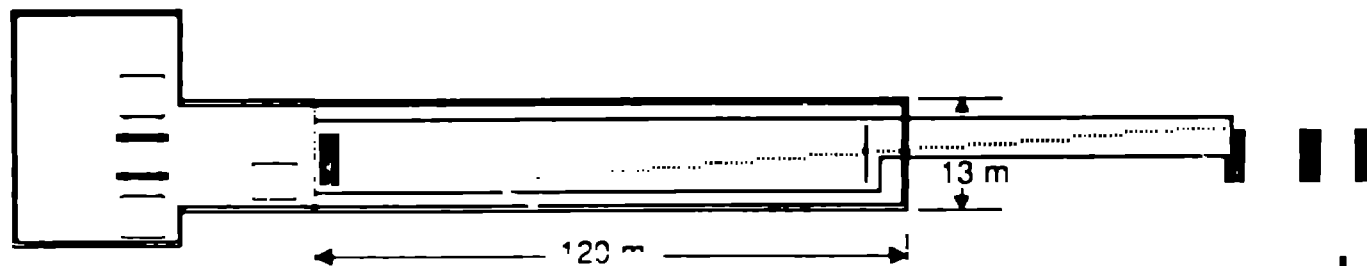

Los Alamos

# Isometric view of three-bay decoder shows separation array opening into Transition Building

---

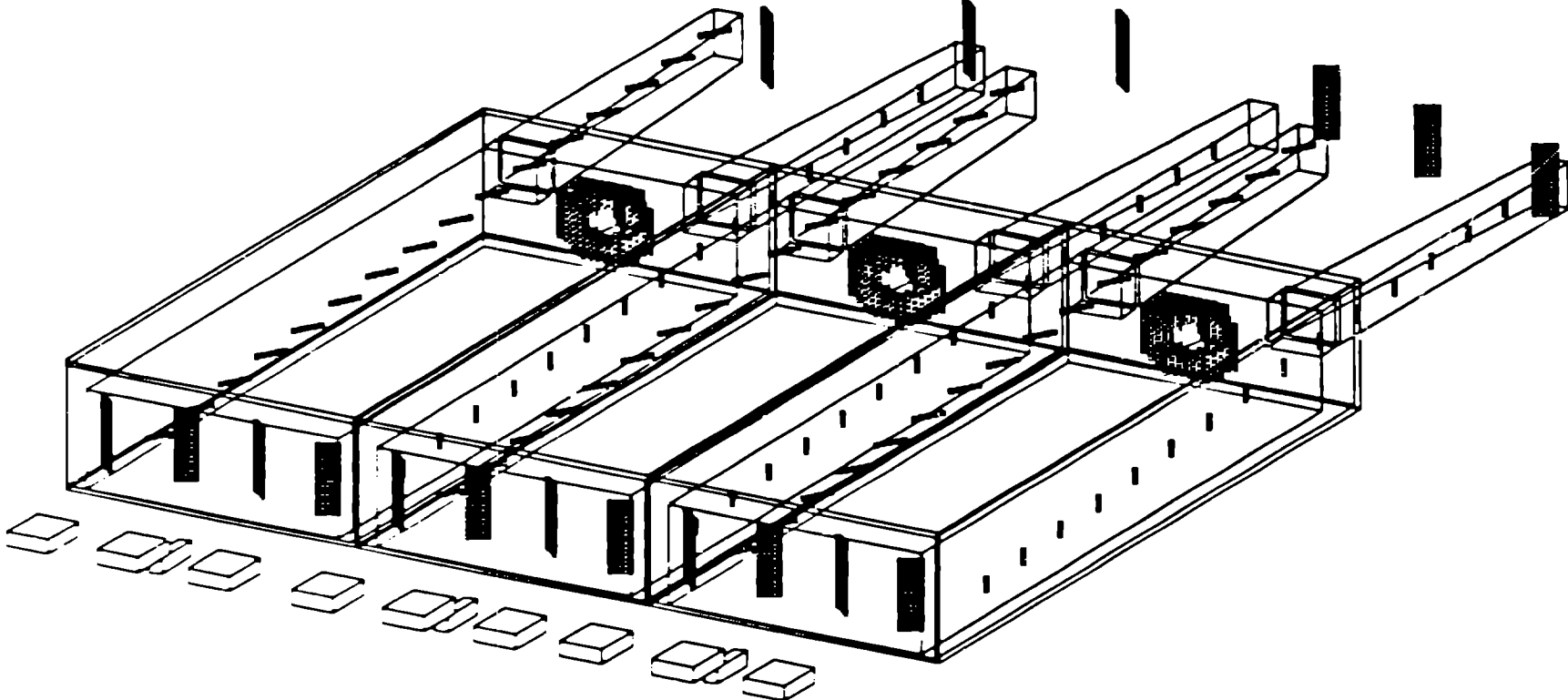

# The Transition and Roundhouse Buildings provide shielding and reduce neutron streaming

---

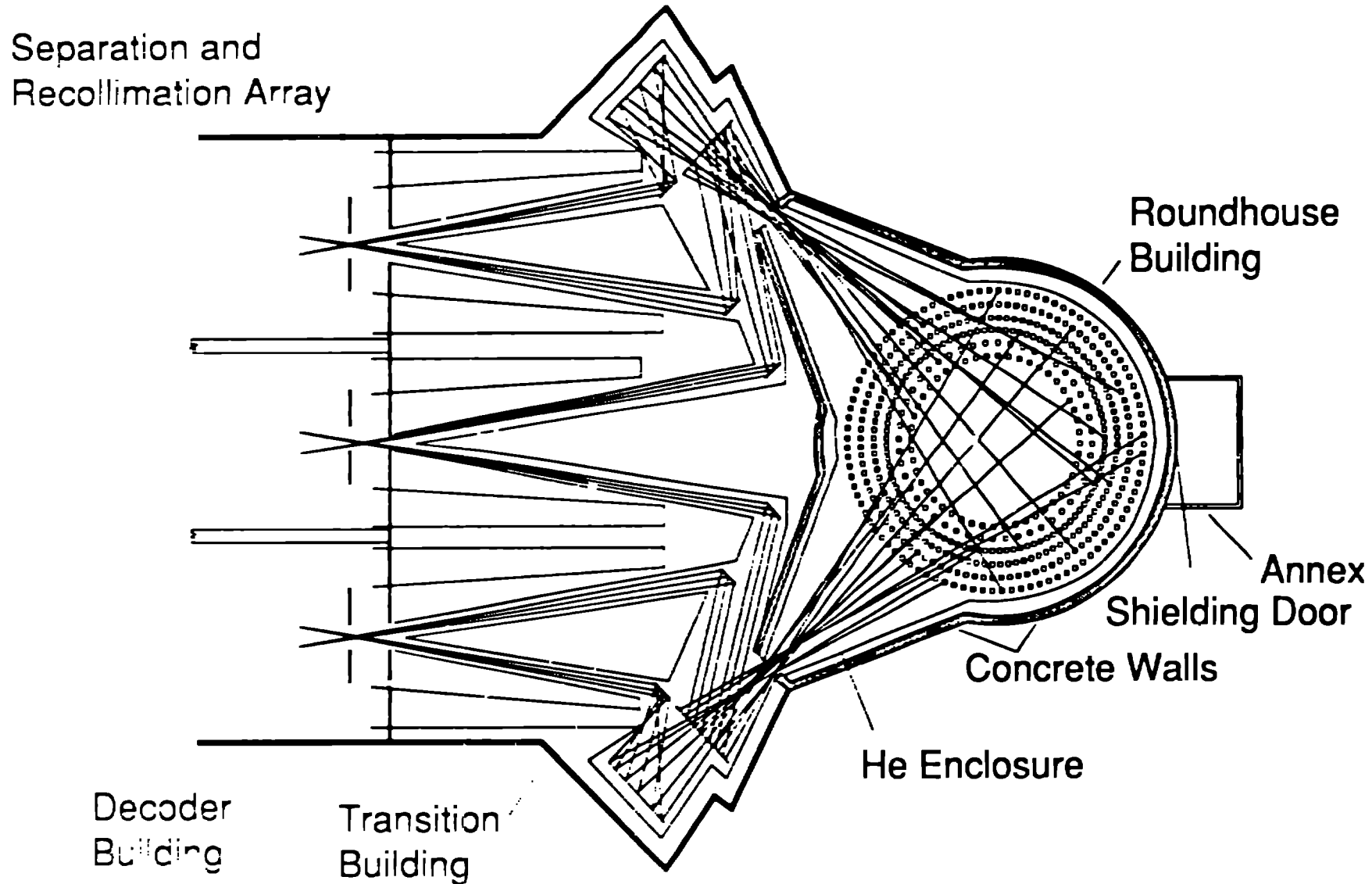

Los Alamos

# Entrance to Roundhouse from Transition Building is through neutron apertures in shielding wall

---

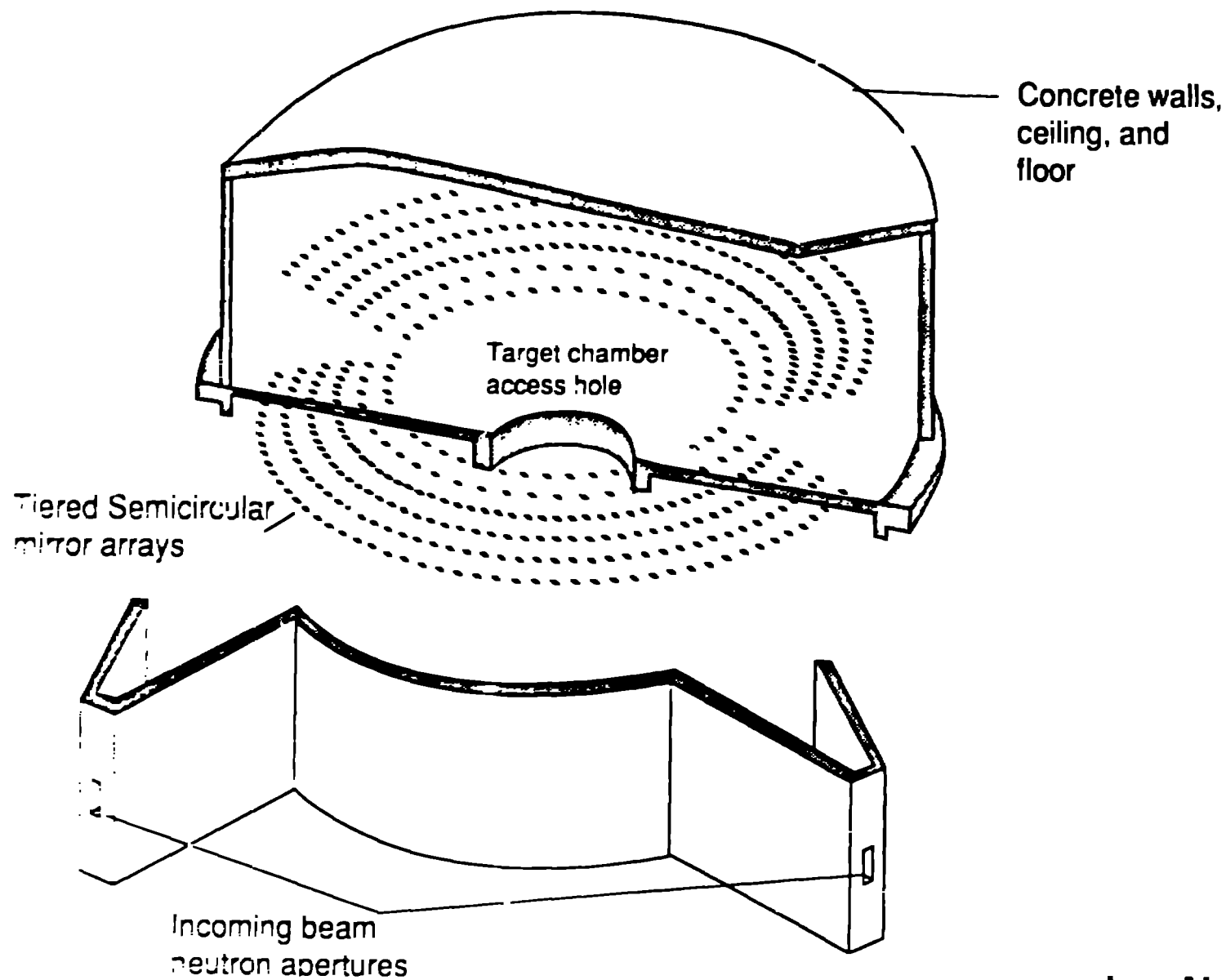



# Roundhouse Building houses 12 tiered semicircular rings of turn mirrors to direct the beams down into the underground Experiment Area

---

Side View

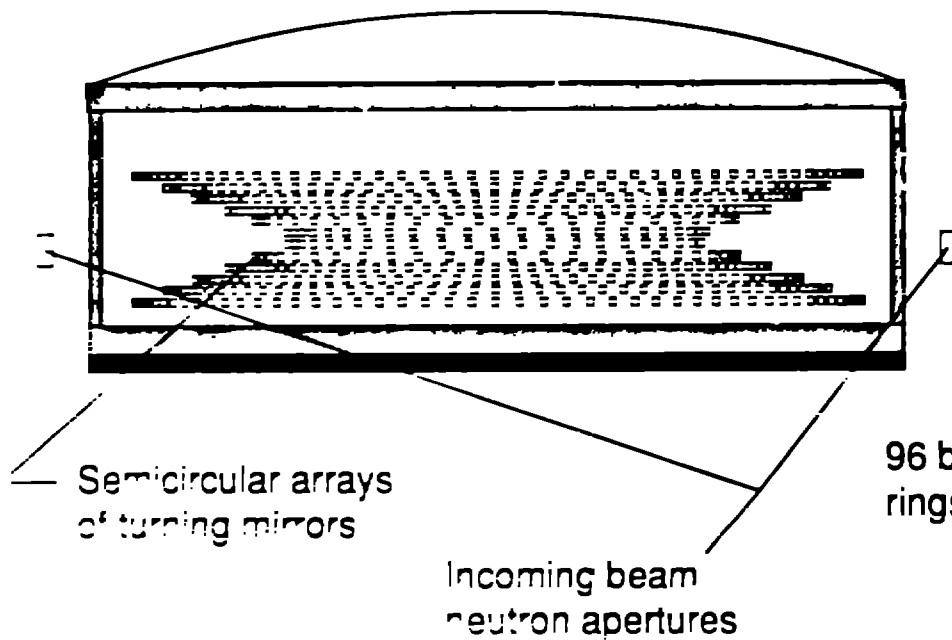

Plan View

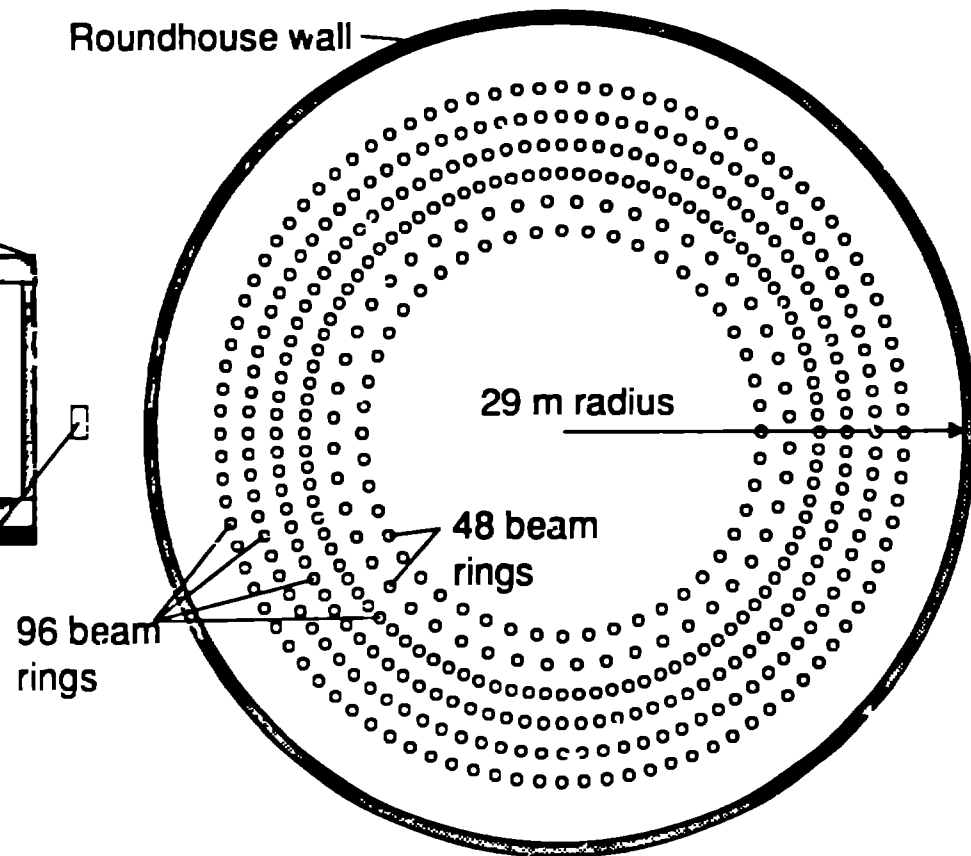

# Underground Experiment Area for indirect-drive targets promotes safety

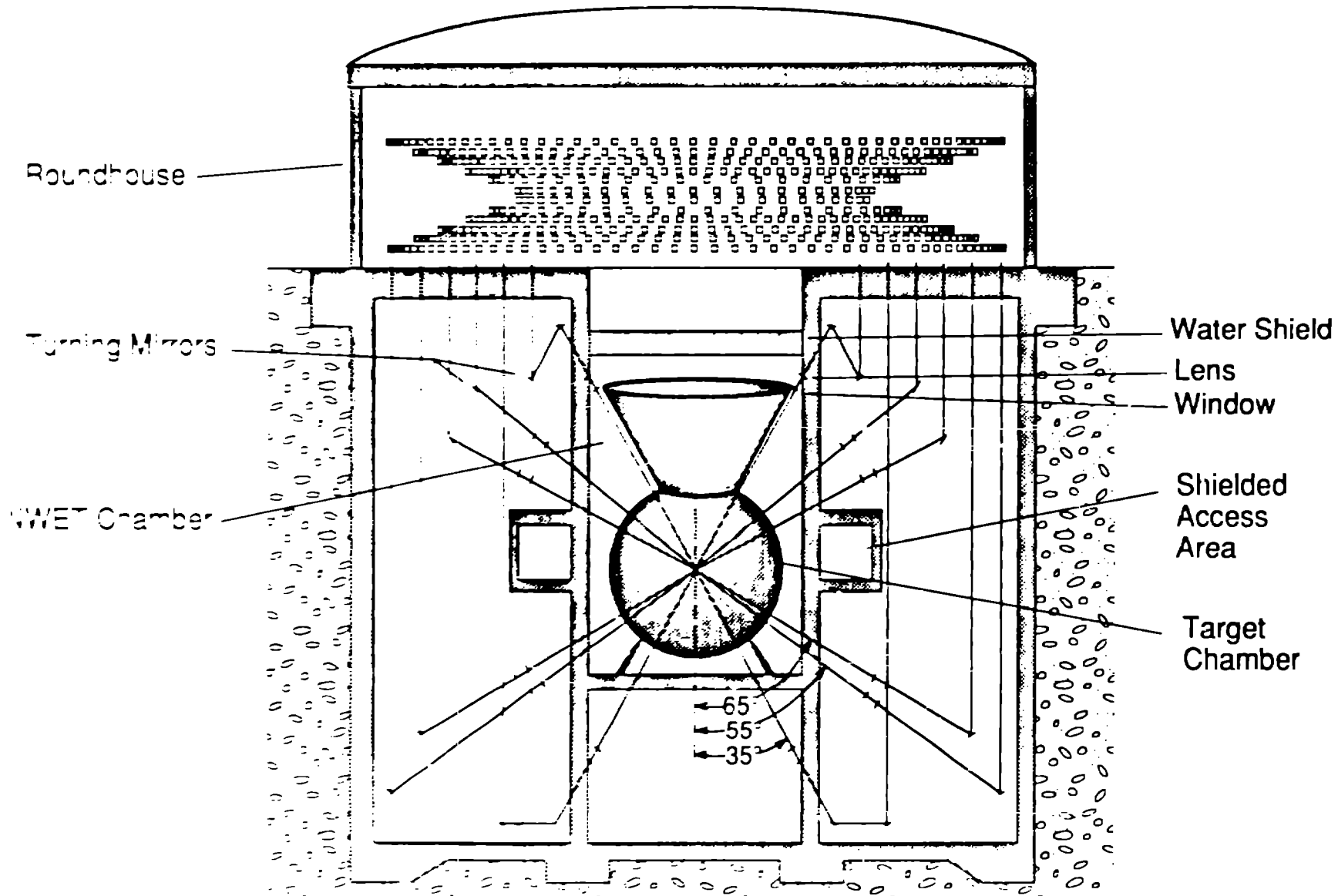

Los Alamos

# LASNEX calculations of target performance predict target yield of 400 MJ

---

## Driver & Target Specifications:

Energy	3 MJ
Number of Beams	480
Illumination Geometry	2-sided indirect
Number of cones per side	3
Beam cone angles	35°, 55°, 65°
Beam quality	< 10 xDL
Min spot size	450 $\mu\text{m}$
Bandwidth	0.5%

**LMF Pulse Shape**

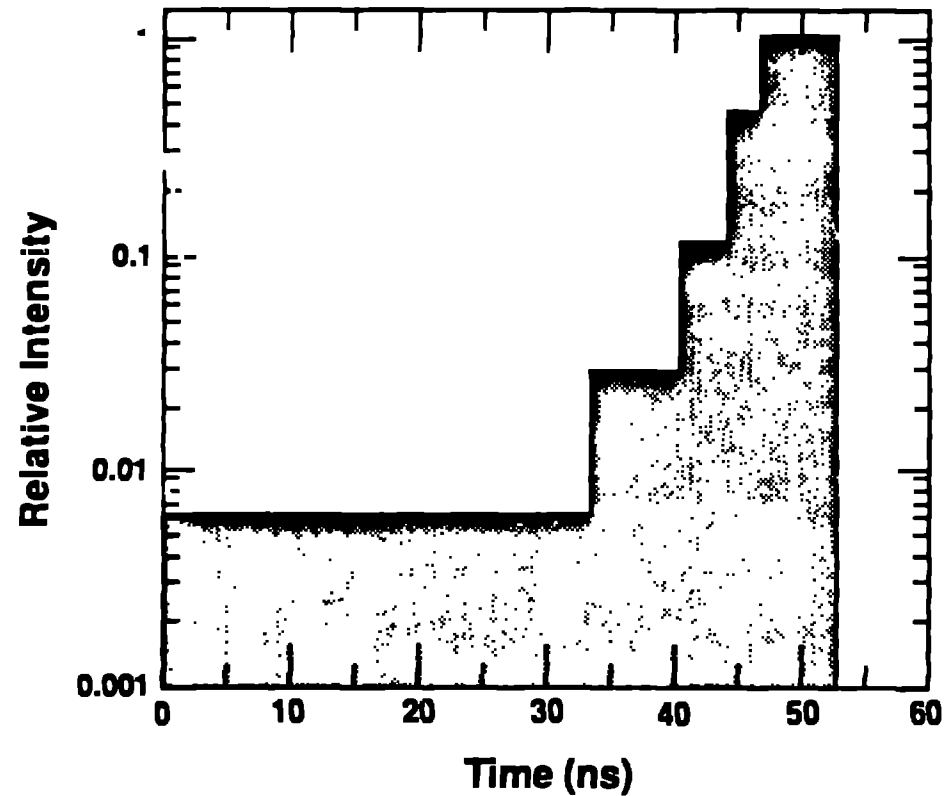

# Bechtel performed an independent cost assessment of the KrF laser-driven LMF

---

	<b>Cost Estimate (1992 M\$)</b>
<b>TOTAL LMF COST</b>	<b>921</b>
1.0 Project Office	125.1
2.0 Site Improvements and Utilities	6.2
3.0 Buildings and Support Facilities	160.7
4.0 Driver	296.3
5.0 Experiment Area Equipment	59.0
6.0 Support Systems	19.8
Escalation to 1992 dollars	68.4
Contingency (25.2%)	185.3

## Summary

# An updated conceptual design for the KrF laser-driven Laboratory Microfusion Facility has been completed

---

- **Laser design improvements include:**
  - *improved laser performance calculations*
  - *larger amplifiers with more compact pulsed power*
  - *more compact amplifier stacking arrangement*
  - *more compact decoder*
- **Experiment Area improvements include:**
  - *better neutron shielding*
  - *better control of neutron streaming*
  - *improved access to target chamber after experiments*
  - *improved target performance calculations*
- **KrF LMF compares favorably with other drivers:**

Driver	Energy (MJ)	Target Yield (MJ)	Cost (M\$)
KrF	3	400	921
Nd:glass	5	200	952
Light Ions	22	1000	1,104