

A major purpose of the Technical Information Center is to provide the broadest dissemination possible of information contained in DOE's Research and Development Reports to business, industry, the academic community, and federal, state and local governments.

Although a small portion of this report is not reproducible, it is being made available to expedite the availability of information on the research discussed herein.

LA-UR--89-2657

DE89 016990

Los Alamos National Laboratory is operated by the University of California for the United States Department of Energy under contract W-7405 ENG 36

TITLE INTERFEROMETRY AND HIGH SPEED PHOTOGRAPHY OF LASER-DRIVEN FLYER PLATES

AUTHOR(S) Dennis L. Paisley, Nelson I. Montoya, David B. Stahl, and Ismael A. Garcia

SUBMITTED TO S.P.I.E. High Speed Photography, Videography, and Photonics, San Diego, CA, August 1989

DISCLAIMER

This report was prepared as an account of work sponsored by an agency of the United States Government. Neither the United States Government nor any agency thereof, nor any of their employees, makes any warranty, express or implied, or assumes any legal liability or responsibility for the accuracy, completeness, or usefulness of any information, apparatus, product, or process disclosed, or represents that its use would not infringe privately owned rights. Reference herein to any specific commercial product, process, or service by trade name, trademark, manufacturer, or otherwise does not necessarily constitute or imply its endorsement, recommendation, or favoring by the United States Government or any agency thereof. The views and opinions of authors expressed herein do not necessarily state or reflect those of the United States Government or any agency thereof.

12/22/89 10:10 AM Page 1

By acceptance of this article, the publisher recognizes that the U.S. Government retains a nonexclusive, royalty-free license to publish or reproduce the published form of this contribution or to allow others to do so, for U.S. Government purposes.

Los Alamos National Laboratory requests that the publisher identify this article as work performed under the auspices of the U.S. Department of Energy.

MASTER

Los Alamos Los Alamos National Laboratory Los Alamos, New Mexico 87545

UNCLASSIFIED

DISSEMINATION IS UNLIMITED

Interferometry and high speed photography  
of laser-driven flyer plates

D. L. Paisley, N. I. Montoya, D. B. Stahl, and I. A. Garcia  
Los Alamos National Laboratory  
Los Alamos, New Mexico 87545

**ABSTRACT**

Laser-driven thin (2-10- $\mu$  thick) plates of aluminum and copper are accelerated to velocities  $\geq 5$  km/s by a 1.06- $\mu$  wavelength Nd:YAG 8-10 ns FWHM laser pulse at power densities 0.7-4.0 GW/cm<sup>2</sup>. Accelerations  $\geq 10^9$  km/s<sup>2</sup> have been achieved. The acceleration and velocity of these 0.4-1.0-mm-diameter plates are experimentally recorded by velocity interferometry (VISAR)<sup>1</sup> and the planarity of impact by streak photography.<sup>2</sup>

**1. INTRODUCTION**

Metals of controlled thickness (2-10  $\mu$ ) are vacuum deposited on UV-fused quartz substrates. A Nd:YAG laser is focused through the substrate and on the metal foil (plate). The laser energy is deposited in a few skin depths<sup>3</sup> ( $\sim 10$ -50  $\text{\AA}$ ) in the foil at the substrate interface. The metal at this interface is converted to a metal plasma at high temperature and pressure resulting in the acceleration of the remaining plate thickness (Figure 1).

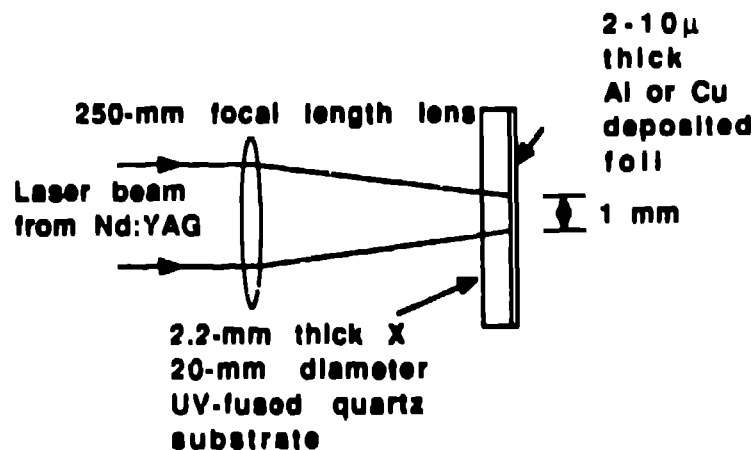

**Figure 1: Technique for launching high velocity flyer plates**

## 2. VELOCITY MEASUREMENT TECHNIQUE

An argon ion laser (514.5 nm) beam from the VISAR is focused on the free surface of the metal foil (plate) to be accelerated. The 1.06- $\mu$  Nd:YAG laser beam (~1-mm diameter) used to accelerate the plate and the argon ion beam (<0.3 mm diameter) are collinearly aligned with a HeNe laser (Figure 2). By properly synchronizing the two lasers and the VISAR electronics, the dynamic interferometric fringes containing velocity information are recorded (Figure 3). The reduced VISAR data from Figure 3 produce a velocity profile (Figure 4). Velocity profiles have been recorded with various metals, thickness, beam diameter, and power densities (Figure 5). Similar experimental techniques by various experimenters<sup>4,5,6</sup> have used pulsed lasers to generate one-dimensional shocks in materials or launch one-dimensional flyer plates. Our technique (Figure 1) uses thinner foils that are attached by physical vapor deposition (PVD) eliminating a bonding material and improving coupling efficiency to  $\geq 30\%$  and has produced relatively high velocities ( $\geq 5$  km/s) with conventional, commercially available lasers. All of these modifications reduce laser energy requirements and improve plate velocity and planarity.

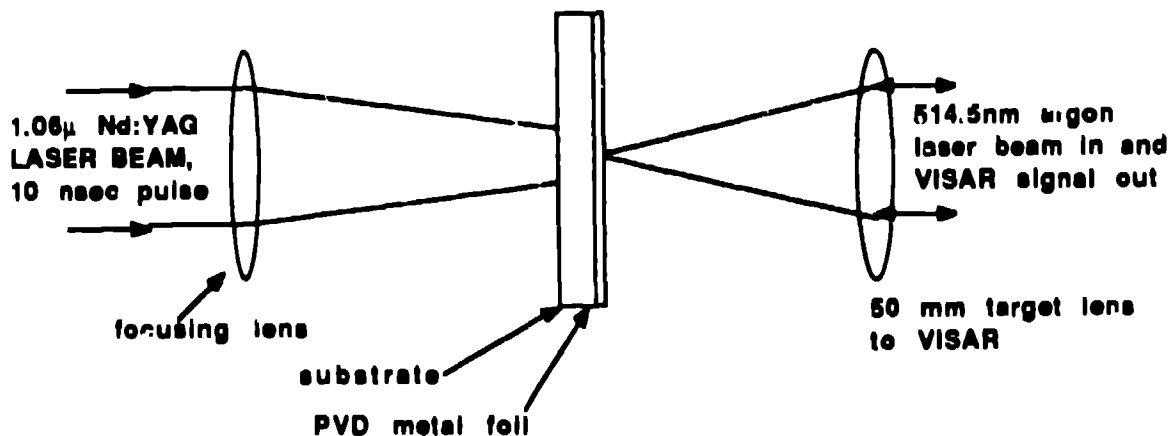

Figure 2: VISAR and Nd:YAG optical axes are collinearly aligned

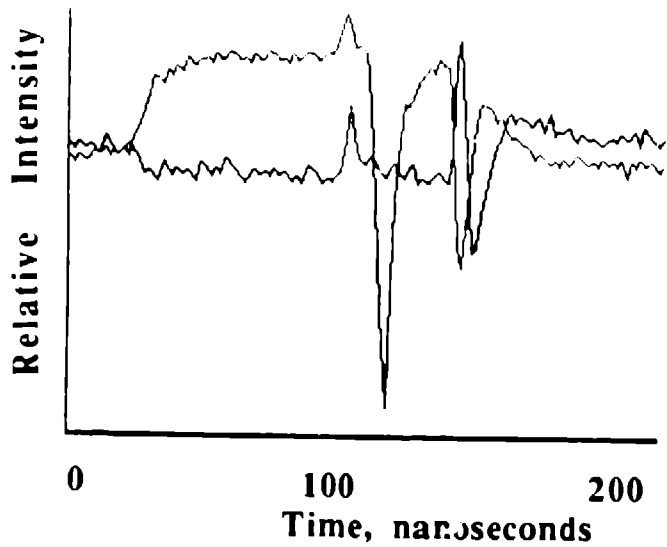

Figure 3: VISAR signals with superimposed fiducials and 10-ns laser pulse that accelerates the plate

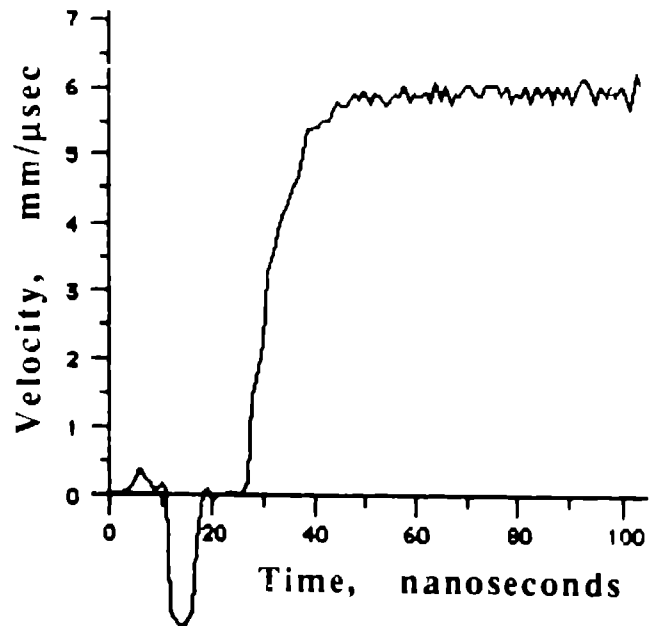

Figure 4: Reduced VISAR velocity data from Figure 3 with negatively superimposed 10-ns laser pulse

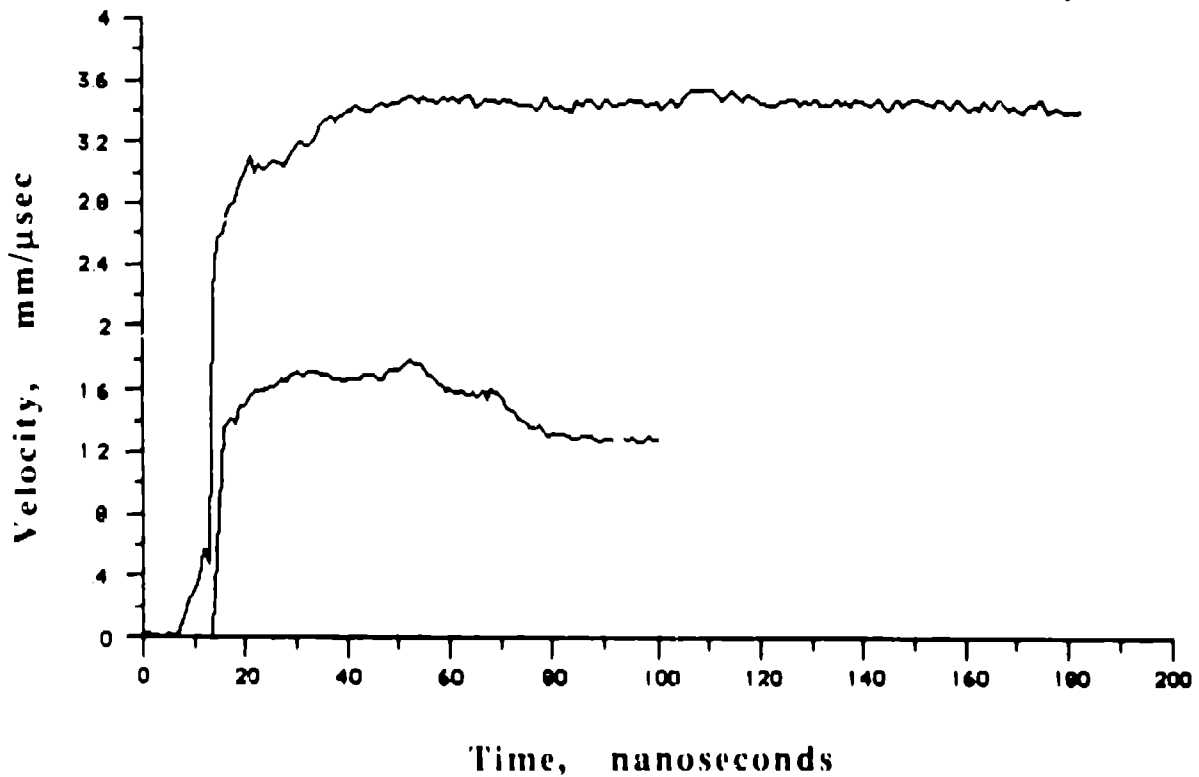

Figure 5: A comparison of several different velocity profiles for plates of different thicknesses

### 3. EXPERIMENTAL METHOD FOR PLATE PLANARITY AND INTEGRITY

Most applications of plate impacts to generate shock waves require a high degree of planarity i.e., minimum tilt, bow, or ripple in the plate surface at impact. Actual quantitative requirements depend on numerous experimental parameters and material properties. To quantify plate impact planarity, a target of transparent material, i.e. PMMA (Lucite®), is positioned 75-100  $\mu$  from the free surface of the plate surface with its parallel to the plate and perpendicular to the flyer plate velocity vector (Figure 6). As the flyer plate impacts the PMMA a bright flash is generated by the shock and recorded with an electronic streak camera.( Figure 7). The planarity can be correlated with plate thickness, flight length, laser power/energy density uniformity , or other experimental parameters. To synchronize the Nd:YAG laser pulse that accelerates the plate with the impact time of the plate on the Lucite® target, a small portion of the laser beam is sent through an optical fiber and placed on the streak camera. The time difference produces an average velocity over a fixed distance.

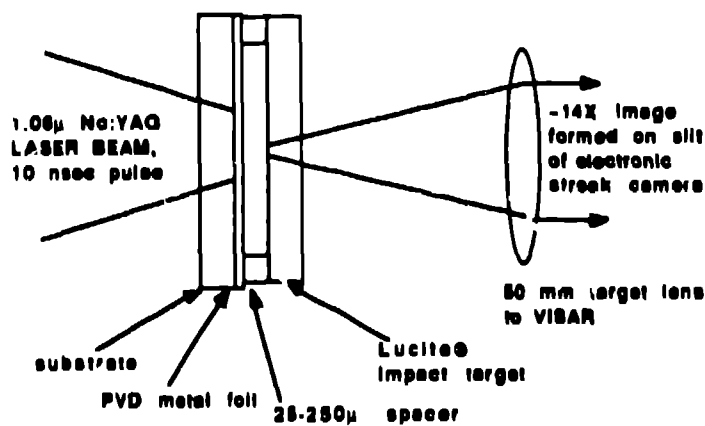

Figure 6: Electronic streak camera technique for recording impact of flyer plate on transparent target

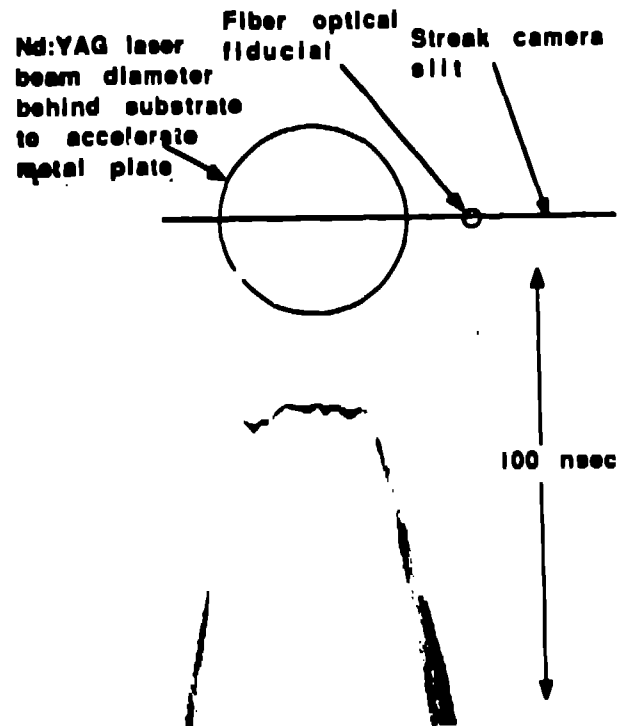

Figure 7: Static and dynamic streak record from technique in Figure 6.

#### 4. CONCLUSIONS

Miniature flyer plates (<1-mm diam) can be accelerated ( $10^9$  km/sec<sup>2</sup>) to high velocities (>5km/s) with good planarity with conventional laboratory lasers. The velocity and planarity can easily be measured and controlled to provide a miniature high velocity shock physics laboratory on a standard optical table. Velocity interferometry and electronic streak photography can be used to quantify flyer plate parameters.

#### 5. ACKNOWLEDGEMENTS

We are indebted to Willard Hemsing, Los Alamos, for VISAR consultation and software and thank Barry Bartell and Ron Snow, Los Alamos, and Art Bailey, EGG/Mound, for vacuum deposition of samples.

#### 6. REFERENCES

1. Proceedings of SPIE High Speed Photography, Videography and Photonics, SPIE Vol. 427, D. L. Paisley, ed., Aug. 23-25, 1983, San Diego, CA
2. Weingart, R. C., et al, Acceleration of thin flyers by exploding metal foils: application to initiation studies, Proc. Sixth Symposium (International) on Detonation, Report ACR-221 (Office of Naval Research, Arlington, 1976).
3. Krehl, P., et al, Correlation of stress-wave profiles and dynamics of the plasma produced by laser irradiation of plane solid targets, Journal of Applied Physics, Vol.46, No.10, Oct 1975, pp. 4400-4406
4. Sheffield, et al, Velocity Measurements of Laser-Driven Flyers Backed by High Impedance Windows, American Physical Society, Proceedings of the Topical Conference on Shock Waves in Condensed Matter, pp, July 22-26,1985, Spokane, WA
5. Ripin, B. G., et al, Laser-plasma interaction and ablative acceleration of thin foils at 1012-1015 W/cm<sup>2</sup>, Physics of Fluids 23(5), pp 1012-1030, May 1980
6. Grun, J. et al, Ablative acceleration of planar targets to high velocities, Phys. Fluids 26(2), pp 588-597, Feb1983