

UNCLASSIFIED
REF ID: A66000

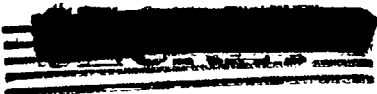

PUBLICLY RELEASABLE

Per JABMUN, FSS-16 Date: 11-8-95
By L. Kolar, CIC-14 Date: 11-27-95

VERIFIED UNCLASSIFIED

Per EMS 6-14-79
By Linda Kolar 11-27-95

LA - 1018



June 27, 1947

This document contains 266 pages

VOLUME 8

Chemistry of Uranium and Plutonium

Chapters 8 and 9

Section C

Classification changed to UNCLASSIFIED
by authority of the U. S. Atomic Energy Commission.

Per ALDR(TID-1400-S2) Sept-Oct 1974

By REPORT LIBRARY 2/21/75

Edited By

Joseph Kennedy



UNCLASSIFIED

UNCLASSIFIED
REF ID: A66000

0110
CHAPTER 8

UNCLASSIFIED

ANALYTICAL METHODS FOR URANIUM, PLUTONIUM, AND ASSOCIATED MATERIALS

H. A. Potratz

8.1 INTRODUCTION

Described in this chapter are certain analytical procedures used routinely in the Los Alamos Laboratory. For detailed information relating to the development, scope and accuracy of the methods described, the reader is referred to Progress Reports and Terminal Reports references which are given under the individual procedures. Methods which differ but little from conventional practice and those which relate to the analysis of materials other than uranium and plutonium are presented in abstract form only.

8.2 PREPARATION OF PLUTONIUM SAMPLES FOR ANALYSIS8.2-1 General Health-Safety Rules

It should be well understood that for health safety purposes extreme care should be taken in handling plutonium metal and its compounds. Every precaution must be taken to avoid ingesting or inhaling them, even in most minute quantities. When handling plutonium in the small amounts required for analytical procedures, the operator should follow carefully the instructions given in Chapter 9 of this volume. Special precautions to be observed in certain analytical procedures are included in the sections below.

8.2-2 Sampling of Plutonium Metal and Compounds

All operations requiring cutting, sawing, or breaking off of metal or requiring transfer of powders must be done in an approved dry box. During these operations, the operator is protected with respirator, cotton overalls, head

0110

UNCLASSIFIED

UNCLASSIFIED

cover and rubber gloves. Since the insides of the dry box gloves are often contaminated, the operator should wear rubber surgeons gloves and tuck sleeves of the coveralls into the cuffs of the rubber gloves while working in the dry box.

The method of cutting plutonium metal depends on whether it is alpha or delta phase metal:

- (1) Alpha phase plutonium is very brittle and large pieces can usually be shattered into smaller sizes by means of a diamond mortar. The smaller pieces can then be cut to the desired size with a pair of diagonal cutting pliers, but care must be taken to prevent loss of small pieces during the operation.
- (2) Delta phase metal is very soft. Large pieces can best be broken up by first flattening them in the diamond mortar to a thickness of a few millimeters, so they can be broken in two with two pairs of blunt-nosed pliers. When the pieces are small, they can be cut with diagonal cutting pliers.

8.2-3 Electrolytic Polishing of Plutonium

The purpose of electrolytic polishing is to remove any surface film of impurities which may adhere to the samples (e.g. slag or oxide). The apparatus for the polishing operation, together with an analytical balance on which the polished samples are weighed, is set up under a good hood. The sample which has been transferred from the dry box to the hood in a closed screw cap vial or weighing bottle, is removed from its container and is placed in a tungsten wire basket, surrounded by a cylindrical platinum cathode, and immersed in a 50:50 mixture of ethylene glycol and syrupy phosphoric acid (Figure 1.) Current is supplied by a 6V storage battery. During the operation of cleaning the main danger comes from the spray carried out of the electrolyte by the evolved gases. The sides of the glass container should extend 3 centimeters

UNCLASSIFIED

03113

Figure 1
Electro-polishing Apparatus

03113
03113

SECRET

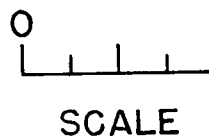
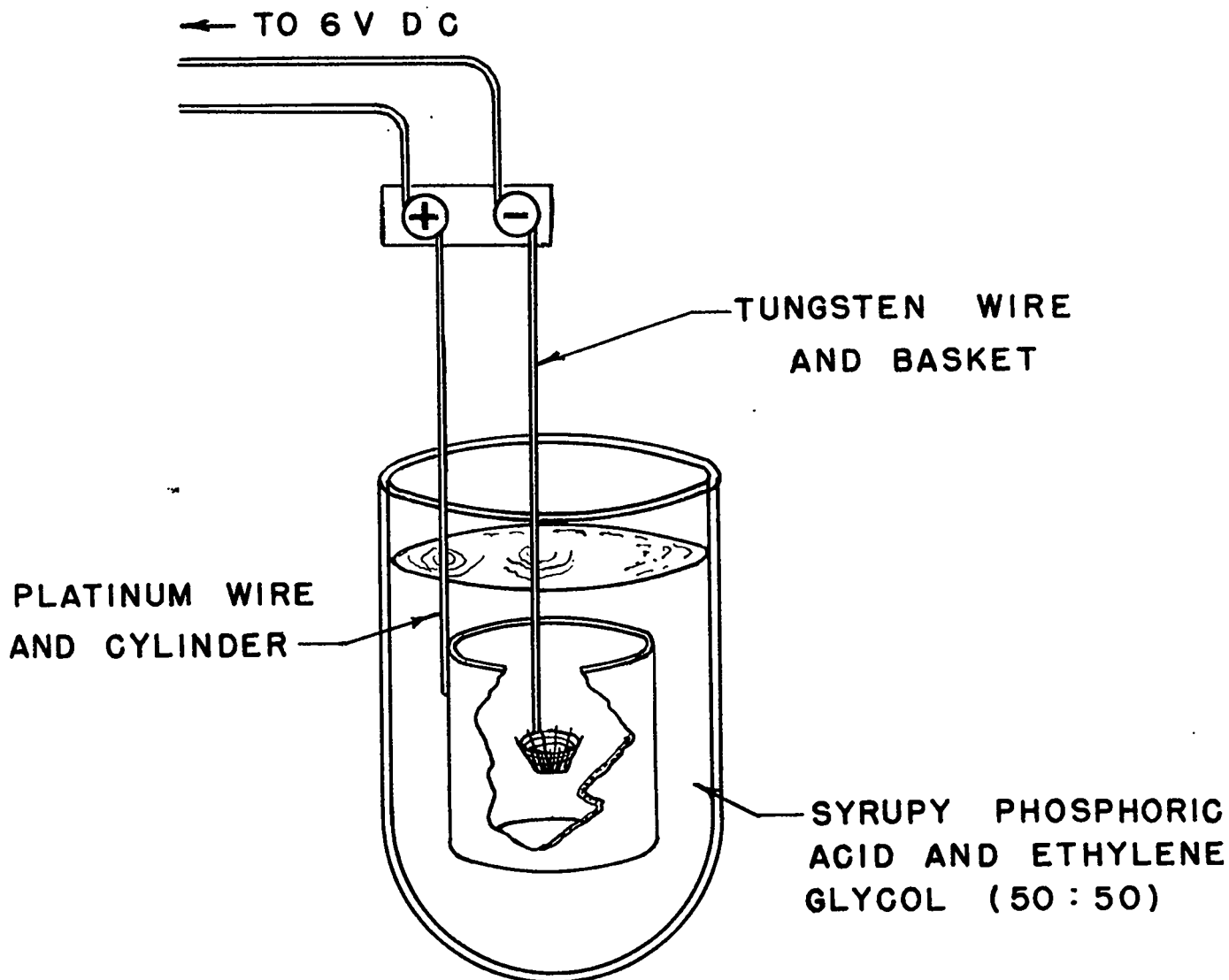

SECRET

SECRET

4711

or more above the surface of the electrolyte. A respirator or face shield must be worn at all times. The sample is electrolyzed until it is bright and silvery (about 2-4 minutes for samples that weigh less than 150 milligrams). If the electrolysis is continued too long, the sample may again turn black. The positive terminal (Pt cylinder) is disconnected and the terminal clamp is raised to lift the basket out of the electrolyte. The piece of metal can then be removed. The sample is immediately immersed in concentrated HNO_3 to rinse off the electrolyte. It is then washed in water and finally in acetone, allowed to dry on a piece of hardened filter paper, and transferred to a tared watch glass if it is to be weighed under the hood, or to a tared screw cap vial or weighing bottle, if it is to be weighed outside the hood. In the case of delta phase samples, it is found that rapid surface oxidation occurs when the sample is washed with water. If the sample is intended for oxygen analysis, this nullifies the effect of polishing. This can be avoided by omitting the water wash, and using acetone both to rinse off the HNO_3 and to dry the sample.

In transferring the sample every possible precaution must be observed to avoid dropping it. The alpha form of plutonium is very brittle and small chips may easily be broken off unless great care is used in handling. The metal should be held in the forceps as short a time as possible. If it is to be transferred to a balance for weighing under the hood, it should be placed on a watch glass during transit and should never be carried in the forceps even if the distance to the balance case is only a few inches. A sample, when it is to be removed from the hood (or dry box), must be placed in a closed container.

8.2-4 Methods for Dissolving Plutonium Metal

Plutonium metal dissolves in HCl , HI , HBr , HClO_4 , and Br_2 with vigorous evolution of gas. It dissolves slowly in H_2SO_4 but is practically insoluble in HNO_3 and H_3PO_4 . Metal samples are most frequently dissolved in HCl . Danger

from spattering during solution in acid. Increases with sample size; precautions required when handling large samples are considerably greater than when handling small ones. These precautions, necessary to avoid loss of material from spray and spatter in dissolving operations, have become, to an extent, standardized.

(1) Apparatus and reagents:

1 milliliter pyrex volumetric flask (test tube shape) for small samples

Solution vessel for larger samples (See Figure 2).

Misco pipets, 50 λ .

Constant-boiling HCl, distilled and stored in quartz.

(2) Procedure for small samples (50 milligrams or less):

Working under a well-ventilated hood transfer the metal sample from its container to a 1 milliliter volumetric flask and add 2 - 3 λ or more of constant-boiling HCl per milligram of metal. If the sample is of the order of 50 milligrams and requires 100-150 λ of acid do not add the acid at once but divide and add in two or three portions. If the acid is run slowly down the side of the flask the stopper may be inserted before spattering starts. Wait until the action has subsided or stopped before adding more acid. If the sample is to be diluted with water wait until evolution of gas has ceased before adding the water; this is to avoid formation of a black precipitate of plutonium dioxide.

(3) Procedure for large samples (greater than 50 milligrams):

Place the sample in the special solution vessel and add the acid with either the attached pipet or the Misco pipet. After evolution of gas has ceased and solution is complete, transfer the solution to the desired container with a syringe pipet or other suction apparatus. Do not pour the solution!

01110

Figure 2
Solution Vessel

01110
01110

SECRET
ACID

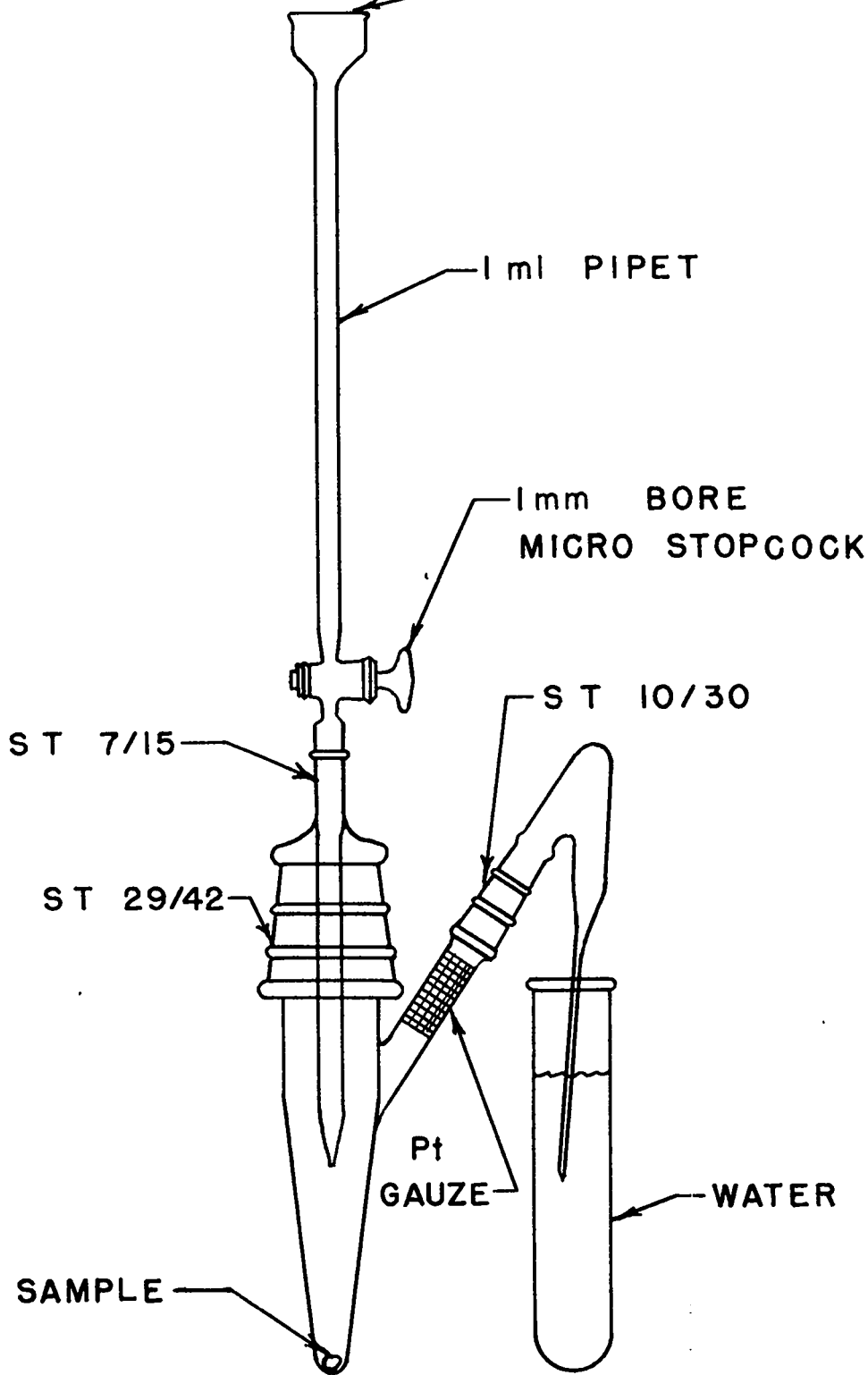

SCALE

SECRET
SECRET

SECRET

8.2-5 Methods for Dissolving Plutonium Tetrafluoride

Because this compound is a fine powder all transfers to solution vessel or other container must be made in a dry box by an operator properly protected with gloves, coveralls, and respirator. Before removing the sample from the dry box in a beaker or other container which cannot be tightly stoppered, it is necessary to wet the sample down with acid or water to prevent air currents from blowing it into the laboratory. In addition, it is good practice to cover the beaker with a piece of Parafilm before removing it from the dry box.

Several methods of solution are available; the choice depends upon what is to be done with the dissolved sample.

- (1) Hot concentrated sulfuric acid. This dissolves plutonium tetrafluoride within a few hours but the resulting stable complex is undesirable for some analytical procedures.
- (2) Hot concentrated nitric or hydrochloric acid. Heating with these acids in an open container may require up to several days for complete solution.
- (3) Hydriodic acid or oxalic acid followed by concentrated HNO_3 . When the tetrafluoride is boiled with these reagents in this order the solution period is less than one hour.
- (4) Hot acid in sealed tube. This is a most satisfactory method for dissolving plutonium fluoride and other difficult soluble compounds.

The procedure is as follows: Prepare a heavy wall pyrex tube (5 millimeters i.d. and 11 millimeters o.d.) about 8 inches long by sealing off one end, taking care to avoid bubbles in the seal. Transfer the sample into the tube and add 0.5 milliliters of either concentrated hydrochloric or nitric acid. Cool the lower end of the tube with liquid nitrogen or dry ice until the contents are frozen;

SECRET

seal off the open end and place the tube in a metal bomb and heat in an oven at 100° C. Solution in HCl is complete in a few minutes but in HNO₃ and hour or two is required. To remove the sample after solution, again freeze the contents, crack the sealed end of the tube with a file and hot rod and transfer the solution with a syringe pipet.

8.2-6 Dissolving Plutonium Oxide

The same precautions are to be observed as with the plutonium tetrafluoride. Hot concentrated sulfuric acid will dissolve black oxide but may or may not dissolve the yellow oxide. The sealed tube technique employing HNO₃ or HCl is satisfactory if the temperature is maintained at about 200° C.

8.3 SPECTROCHEMICAL PROCEDURES

8.3-1 Special Health Safety Precautions to be Observed in Spectrochemical Analysis of Plutonium Metal and Its Compounds

Plutonium metal and its compounds are handled in the spectrochemical laboratory in three essentially different procedures, and the safety precautions to be observed are discussed below under the topics: "Pyro-electric Method", "Direct Spark Method" and "Cupferron Method".

(1) Pyro-electric Method

Material received for analysis by this method is in the form of oxide, metal, or nitrate solutions. The conversion of metal into oxide, the compound required by the method, is carried out in a dry box which also serves to house the arc source, a balance, and all tools necessary for the preparation of the sample for arcing. Figure 3 is a view into the left side of the dry box in which the operations of sample oxidation, weighing, grinding, and electrode-loading are carried out. Samples are admitted into this chamber through a double-door vestibule at the left of the box; at least one of the doors must always be

SECRET

Figure 3

Left side of Dry Box

APPROVED FOR PUBLIC RELEASE

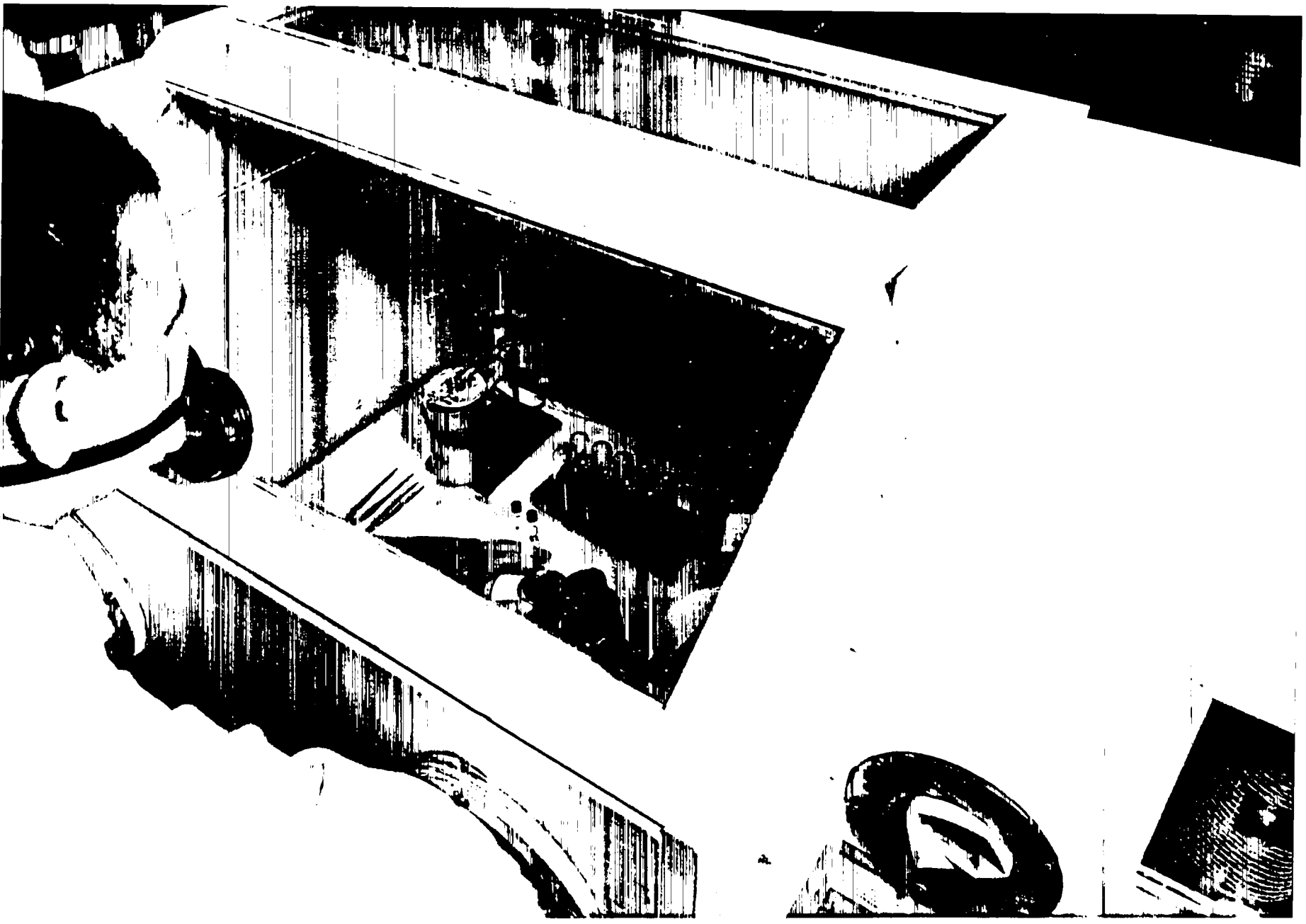

APPROVED FOR PUBLIC RELEASE

closed. The operator, wearing a tightly fitting dust respirator, inserts his gloved hands into tightly fitting gauntlets in the front of the box.

Metal specimens are transferred from their vials to small platinum crucibles in a micro-furnace and ignited at 700-800°C until conversion to the black oxide is complete. Nitrate solutions, on the other hand, cannot be evaporated in the dry box, which has no exhaust facilities. They are evaporated to dryness in platinum crucibles under an infra-red lamp in a well-ventilated hood and then transferred to the dry box in a nest of alternately inverted beakers. There the conversion to oxide is completed in the micro-furnace.

Two milligram quantities of galliumoxide and 73 milligrams of uranium oxide (U_3O_8) are weighed into vials on an analytical balance and introduced into the dry box. Twenty-five milligrams quantities of plutonium oxide are weighed out on a torsion of assay balance in the dry box and there ground with the gallium oxide-uranium oxide mixture. The well-ground mixtures are placed in electrode craters in the dry box and transferred in electrode holder blocks to the arc chamber through the door of the separating partition. Great care should be exercised to minimize spillage during the weighing, grinding, and transfer operations.

Samples are arced in the conventional pyro-electric manner, the operator continuing to wear a dust respirator (Figure 4). Each electrode is returned to its position in the electrode holder block after arcing and, at the conclusion of a series, the block is returned to the left compartment of the dry box. There each electrode pair is placed in a vial for transport to recovery. The operator should present himself for a "nose count" as soon as possible after arcing a series of samples.

Occasional accidents will occur in which an electrode may be dropped and its contents spilled upon the floor of the dry box; small losses may occur

Figure 4
Pyro-electric Spectrochemical Apparatus

APPROVED FOR PUBLIC RELEASE



APPROVED FOR PUBLIC RELEASE

during weighing and grinding. These mishaps are inevitable in routine operation, although every effort should be made to minimize their number. It is therefore necessary to have the interior of the dry box decontaminated at frequent intervals. At such times a decontamination squad, equipped with dust respirators, rubber gloves, and laboratory coveralls should remove a window from the dry box and gather up the spilled material with brushes and moistened cheese cloth. A warning red light on the outside of the room door should be turned on to indicate that entry into the room is prohibited during such times. Following clean-up of the box interior and replacement of the window, the floor and exterior of the dry box should be monitored with a portable alpha-counter ("Pluto"). As a final precaution, the room should be left uninhabited for several hours following decontamination to allow any active dust to settle.

(2) Direct Spark Method

Materials received for analysis by this method consist of metal, tetrafluoride, or nitrate solutions. See Section 8.2, above, for precautions to be observed in dissolving plutonium metal and tetrafluoride.

Beyond the dissolving operations, safety precautions are to be observed at two stages: (a) evaporation of solutions on electrodes and (b) sparking of electrodes.

- (a) Concerning the first -- the evaporations should be carried out under infra-red lamps in a well ventilated hood by an operator wearing rubber gloves, a dust respirator or plastic face shield, and a laboratory garment which covers the arms and trunk completely. The rate of evaporation should be regulated by a Variac in series with the lamps so that spattering never takes place. All equipment used for the evaporation should rest in a stainless steel tray in the hood, so that in event of spillage the contamination area is confined. The hood and equipment should be

monitored regularly to detect the rise of contamination and decontamination carried out when counts of $100/\text{dm}^2/\text{min.}$ are exceeded.

- (b) Precautions to be observed in the sparking of electrodes are two-fold: electrical and chemical. The operator should realize that the danger of receiving a fatal shock is ever-present around the spark source and chamber. The case of the spark source and chamber and the bed of the spectrograph have been grounded, but the operator should inspect the ground connections to see that they are intact before operating. Evidence of frayed cables or loose contacts on the high voltage leads should be repaired immediately or called to the attention of the supervisor for repair. Evidence of anything abnormal in the behavior of the equipment (odor of burning insulations, stray sparks or corona discharges at connection points, and irregular sounding spark discharges) should be called to the attention of the supervisor for repair. The floor upon which the operator stands should be clean and dry. Under no conditions should the operator stand in water left from mopping the floor. As a final precaution the operator should avoid unnecessary body contact with the case of the spark source, chamber, or spectrograph during operation.

Regarding safeguard from the radio-chemical standpoint, the operator should wear rubber gloves, a dust respirator, and a full length laboratory smock while sparking electrodes. Electrodes bearing any quantity of radioactive material whatsoever should be sparked inside the chamber provided (Figure 5). Its door must be tightly closed except when electrodes are being

Figure 5
Sparking Chamber

APPROVED FOR PUBLIC RELEASE

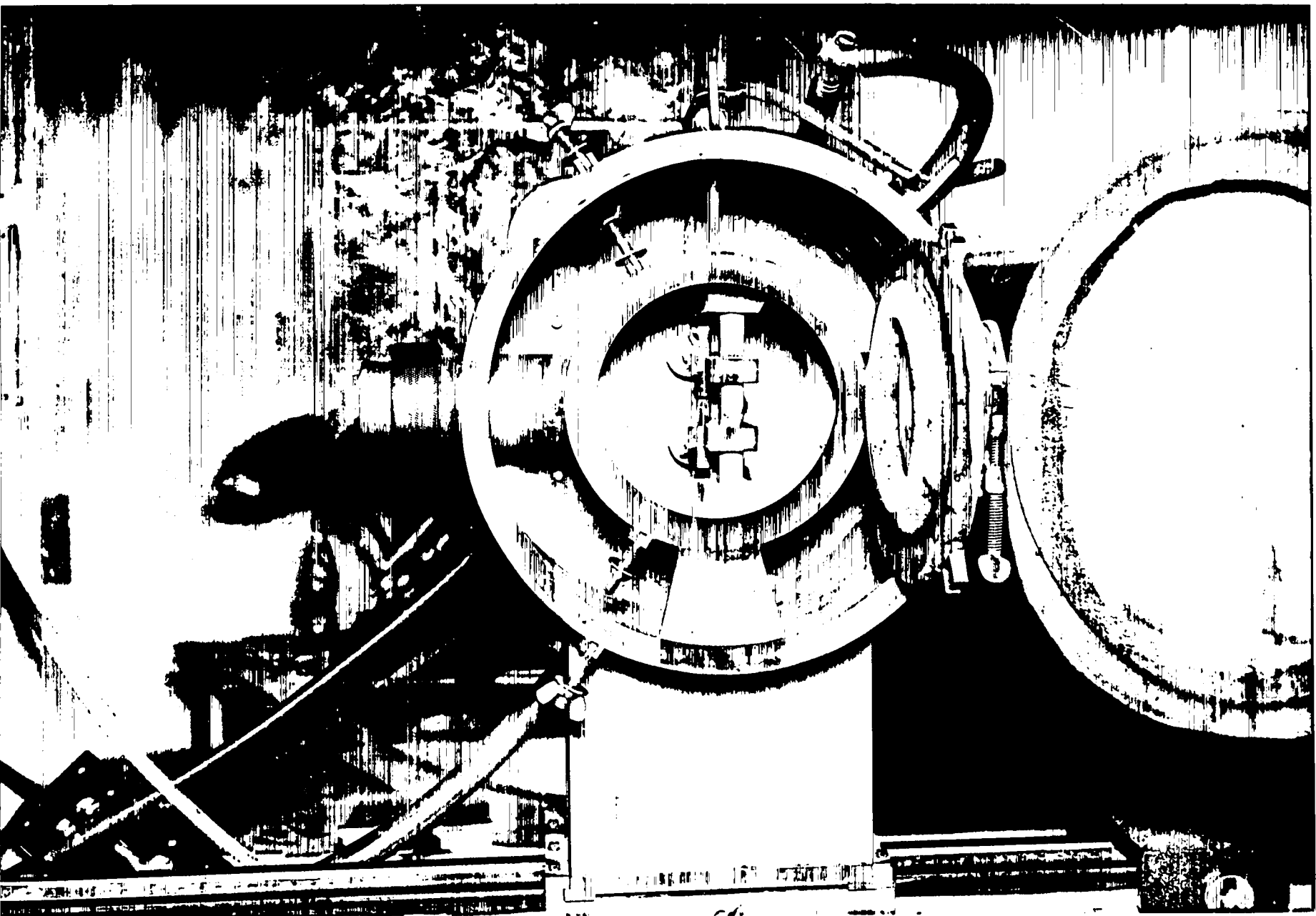

APPROVED FOR PUBLIC RELEASE

inserted or removed. Electrodes must be handled only with pliers or forceps reserved for active materials. Electrodes which have been sparked may still bear some activity, and should not be mixed with uncontaminated electrodes. They should be placed in a beaker, and the contamination removed by dissolving in 1:1 nitric acid, the solution being saved for recovery. Electrodes, decontaminated in this way, may be re-used.

Regular checks of the activity of the floor, tables and optical bench should be made with a portable alpha counter and decontamination carried out when indicated. The spark chamber and all tools used in connection with the sparking of active materials must be regarded as contaminated and should be touched only with gloved hands.

Hands should be checked for contamination following use of the equipment and thoroughly scrubbed with soap and water if any is detected. Nose counts should be taken after active electrodes are sparked.

(3) Cupferron Method

Material received for analysis by this method is in the form of nitrate or chloride solutions. Metal or tetrafluoride samples will have been dissolved elsewhere, and by the procedure already described. The operator must wear rubber gloves and a full-fitting laboratory coat while carrying out the chemical separations in a well-ventilated hood (Figure 6). Care should be taken in the evaporation of solutions that no spray be given off. Frequent monitoring of the glass floor of the hood should be made to detect the activity resulting accidental spillage.

For precautions to be observed in sparking electrodes see (b) under "Direct Spark Method" above.

Figure 6
Well ventilated hood.

APPROVED FOR PUBLIC RELEASE

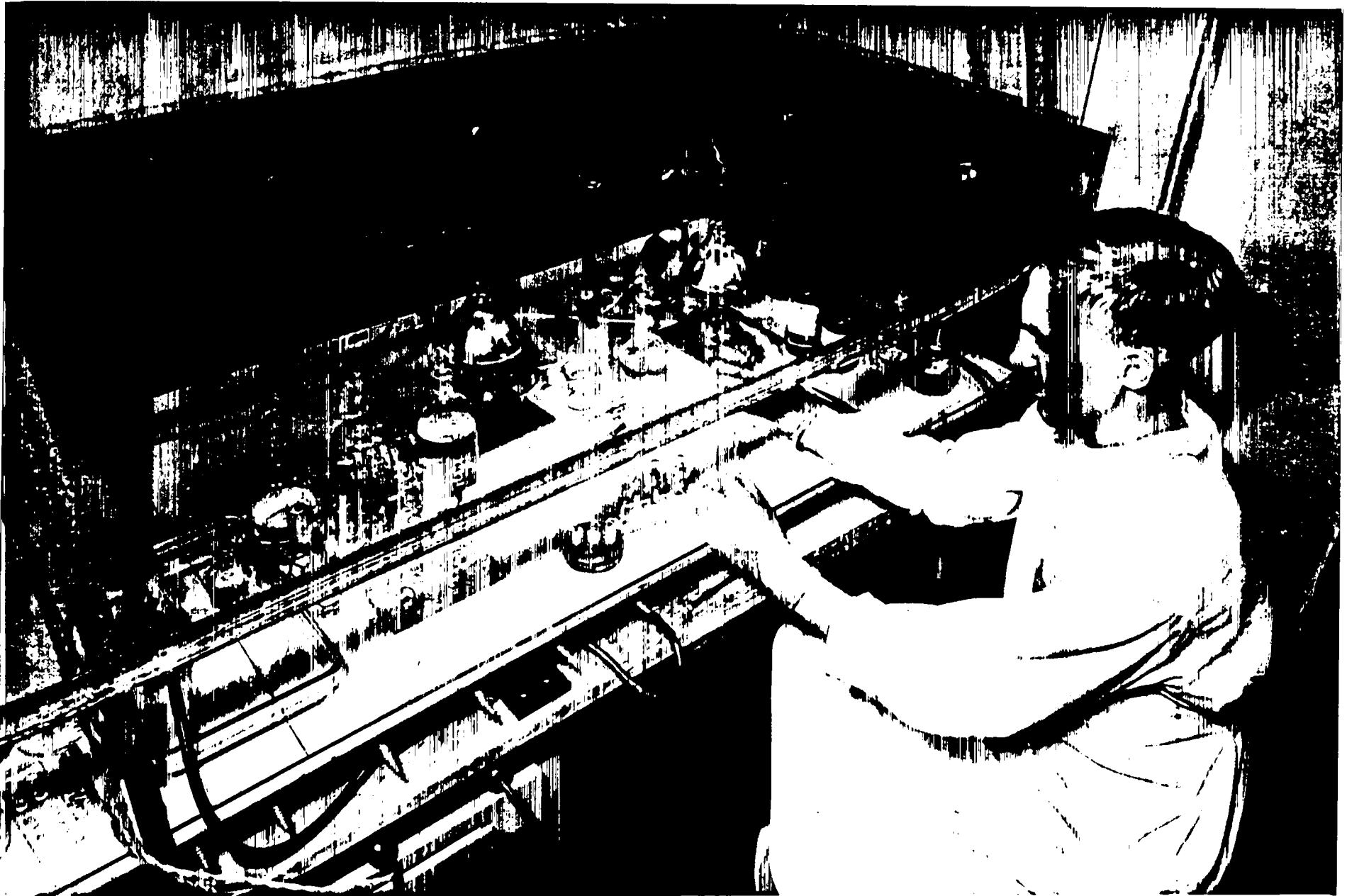

APPROVED FOR PUBLIC RELEASE

All individuals carrying out analytical operations on plutonium materials should present themselves daily for a nose count. Weekly urine specimens must be submitted to detect at the earliest time evidence of pathological damage.

8.3-2 Spectrochemical Determination of Intermediate and Heavy-Element Impurities
In Plutonium Metal and Compounds by the Direct Copper Spark Method

(1) Abstract

A hydrochloric acid solution containing fifty micrograms of plutonium is evaporated on copper electrodes and the spark spectrum photographed in the range, 2500 A° - 5000 A°. The quantity of impurities present is estimated by comparison of the densities of their spectrum lines with the corresponding lines of standard spectra photographed on the same plates.

Limits of Sensitivity (based upon analysis of 50 micrograms of metal)

<u>Element</u>	<u>ppm first order</u>
Be	10
Mg	100
Al	200
Ca	100
Ti	1000
V	-----
Cr	200
Mn	200
Fe	400
Co	-----
Ni	-----
Zn	4000
Zr	1000
Mo	-----
Cd	1000
Sn	2000
La	2000
Ce	1000
Bi	200
Th	4000

(2) Reagents

- (a) Constant-boiling HCl, distilled from and stored in quartz vessels.
- (b) Nitric acid, distilled from and stored in quartz vessels.
- (c) Water, distilled from and stored in quartz vessels.

(3) Apparatus and Materials

- (a) 1 ml. glass-stoppered pyrex volumetric flasks.
- (b) Misco syringe and 50 micro-liter pipet tips.
- (c) 1 ml. platinum crucible
- (d) Electrode evaporator. See Figure 10.
- (e) $\frac{1}{4}$ " dia. x $1\frac{1}{2}$ " long copper electrodes. Ends should be freshly faced on lathe and sides machined lightly to a distance of $\frac{1}{2}$ " back from end.
- (f) Spark discharge chamber. See Figure 7.
- (g) 4" x 10" 103-0 photographic plates.
- (h) Wadsworth fully automatic stigmatic grating spectrograph, 21' grating, 15,000 lines per inch. (Jarrell-Ash Co.)
- (i) Dietert spark unit
- (j) Dietert rocking developing machine
- (k) Bausch and Lomb viewing box.

(4) Procedure

(Heed Health Safety Rules Outlined Above)

(a) If metallic, weigh out a 500 microgram sample and dissolve in the smallest possible quantity of constant-boiling HCl. Dilute to volume with quartz-distilled water in a 1 milliliter glass-stoppered pyrex volumetric flask. Examine the solution critically for undissolved material; if a residue remains, shake the solution until it is uniformly dispersed throughout and rapidly withdraw a 50 micro-liter aliquot. Transfer the aliquot to the top of a copper electrode and evaporate it to dryness in an electrode evaporator. Prepare two such electrodes.

(b) If the sample is an HCl-soluble salt, weigh out a quantity equivalent to 500 micrograms of metal and dissolve. Proceed as above.

Figure 7
Spark Discharge Chamber

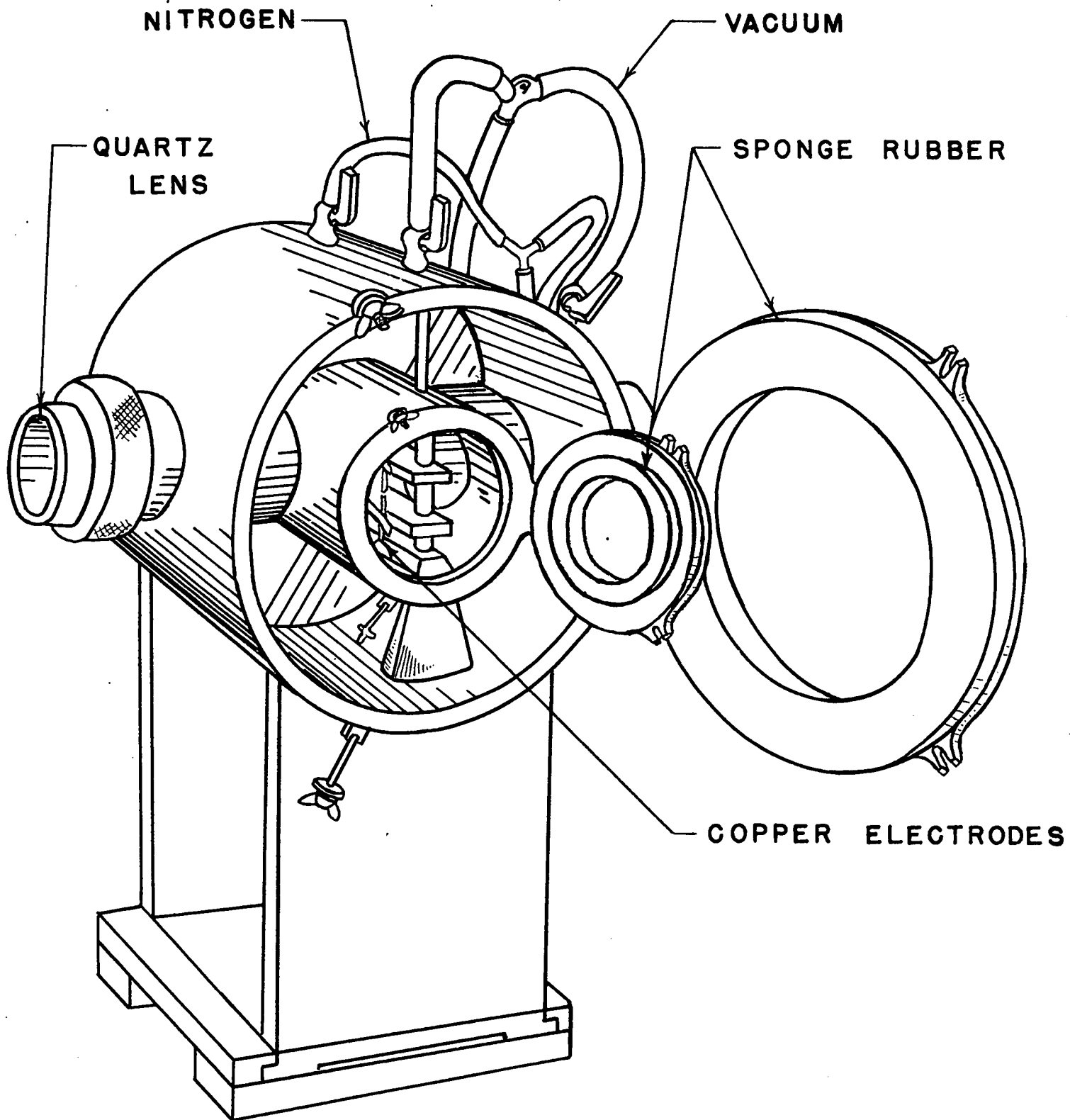

(c) If the sample is insoluble in HCl but soluble on digestion in HNO_3 (e.g. plutonium tetrafluoride), weigh out a quantity equivalent to 500 micro-grams of metal in a 1 milliliter platinum crucible. Add the smallest possible quantity of quartz-distilled HNO_3 that will dissolve the sample on digestion under an infra-red lamp; evaporate the resulting nitrate solution just to dryness. Add 50 micro-liters of constant-boiling HCl and dilute to 1 milliliter with quartz-distilled water in a 1 milliliter glass-stoppered volumetric flask. Proceed as above (a).

(d) Prepare a series of copper electrode pairs bearing the following total weights of the elements of interest: 1.0, 0.5, 0.2, 0.1, 0.05, 0.02, 0.01, 0.005, 0.002, 0.001 micrograms and reagent blank. This is most conveniently done by starting with a stock solution containing 1 milligram per milliliter of the following elements in 1:1 HCl: Be, Mg, Al, Ca, Ti, V, Cr, Mn, Fe, Co, Ni, Zn, Zr, Mo, Cd, Sn, La, Ce, Bi, and Th. Dilute a 5 milliliter portion of this stock solution to 50 milliliter in a glass-stoppered graduated cylinder with quartz-distilled water; this solution contains 100 micrograms per milliliter. Transfer a 5 milliliter aliquot of this solution to another 50 milliliter cylinder marked No. 1 and dilute to volume. Prepare succeeding standard solutions in accordance with the following table:

<u>Cylinder No.</u>	<u>Dilute () ml. of Cyl.</u>	<u>(No.) to 50 ml.</u>	<u>Micrograms/ml.</u>
1	-	-	10
2	25	1	5
3	20	2	2
4	25	3	1
5	25	4	0.5
6	20	5	0.2
7	25	6	0.1
8	20	7	0.05
9	20	8	0.02
10	25	9	0.01

Use 100 micro-liters of each standard solution per electrode pair to prepare electrodes bearing a total of 1.0, 0.5, etc. to 0.001 micrograms of each element. Evaporate the solutions on the copper electrodes in the same manner as for samples, using the infra-red electrode evaporator or the nichrome coil evaporator. Prepare each standard solution fresh each day to avoid losses in strength due to hydrolysis or adsorption.

(e) Set the Dietert spark unit to give the following conditions: power in-put, 2 KVA; inductance, 8; in-put voltage, 230; rotary gap, 10; primary voltage, 95 - 100.

Set the timer relay for an exposure of 60 seconds. Close the slit of the Wadsworth spectrograph to 25 microns. Insert a pair of copper electrodes into the holders in the discharge chamber and align them laterally and vertically at a separation of 2 millimeters by projecting their shadow-image on the alignment screen on the optical axis behind the chamber. Strike a spark between the electrodes, and open the spectrograph shutter. Remove the camera from the back of the instrument and observe the spectrum in the visible region with a hand lens through the camera port. This is a check on the electrode alignment, and should reveal the full slit height lines as uniformly bright along their length. Set the Hartmann diaphragm to give lines 2 millimeters tall and load the camera with 2 103-0 plates. Set the camera to photograph the range 2500 Å - 5000 Å.

(f) Insert the 1.0 microgram standard copper electrodes in the holder in the discharge chamber, close the door of the latter, and pass nitrogen through the chamber for one minute. Stop the flow of nitrogen, open the spectrograph shutter and strike the discharge. Rack the plate up 3 millimeters and repeat the operation for succeeding standards. Spark the sample or samples about mid-way between the first and last standard.

(g) Develop the plates in total darkness for 3 minutes at 18.0°C in

Eastman D-19 using rocking development. Fix in F-5 for 10 minutes after immersion in an acetic acid short stop for about 10 seconds. Wash plates in a vertical stream of water for 10 minutes, rinse in distilled water, and dry out of contact with dust after removal of most of the water with a moist viscose sponge.

(h) Examine the plates on a viewing box or in a modified Judd-Lewis plate comparator, comparing the line densities of the sample spectra with those of the standards photographed on the same plate. Subtract the quantity of each element appearing in the reagent blank from the quantity of that element appearing in the sample.

(5) References

The development of the method described is covered in the following project reports:

CK-670	LAMS-122
CK-877	LAMS-127
CK-928	LAMS-146
CK-993	LAMS-155
CK-1229	LAMS-190
CK-1326	LAMS-211
CC-872	LAMS-217
LAMS-72	LAMS-249
LAMS-86	LAMS-266
LAMS-97	LAMS-386 (Terminal Report
LAMS-109	

8.3-3 Spectrochemical Determination of Impurities in Plutonium Metal and Compounds by the Copper Spark-Cupferron Extraction Method

(1) Abstract

Tri- or tetra-valent plutonium is separated from Li, Be, Na, Mg, Al, K, Ca, Mn, Co, Ni, Zn, Sr, Cd, Sn, Ba, La, Ce, Hg, and Pb by extraction of plutonium cupferride with chloroform. The aqueous phase is evaporated on copper electrodes, and the latter sparked to produce the impurity spectrum. Comparison of the densities of the impurity lines with standard spectra permits estimates of the amounts of impurities present.

(2) Limits of Sensitivity

(Based upon analysis of 5 milligrams of metal)

<u>Element</u>	<u>ppm</u> <u>first order</u>	<u>ppm</u> <u>second order</u>
Li	1.0	---
Be	0.1	0.4
Na	5	---
Mg	2	20.0
Al	2	20.0
K	20	---
Ca	2	20.0
Mn	2	---
Co	10	---
Ni	4	---
Zn	40	---
Sr	1	---
Cd	20	---
Sn	20	---
Ba	1	---
La	2	---
Ce	20	---
Hg	40	---
Pb	20	---

(3) Reagents

- (a) Constant-boiling HCl, distilled from and stored in quartz vessels.
- (b) Diluted quartz-distilled FCl, prepared by diluting 12 milliliters of c.b. HCl to 100 milliliters with quartz-distilled water.

24

- (c) Purified cupferron (Ammonium salt of N-nitroso phenylhydroxylamine). See section 8.10.
- (d) Chloroform (Baker's Analyzed)
- (e) Ether (Mallinckrodt)
- (f) Quartz-distilled water

(4) Apparatus and Materials

- (a) Electrolytic reduction cell. See Figure 8.
- (b) 1 milliliter glass-stoppered pyrex volumetric flasks.
- (c) 10 milliliter glass-stoppered pyrex graduated cylinder.
- (d) 1 milliliter platinum crucible
- (e) Misco syringe and quartz pipet tips (1 milliliter capacity).
- (f) Cylindrical micro-furnace. See Figure 11.
- (g) Infra-red evaporating apparatus. See Figure 9.
- (h) Electrode evaporator. See Figure 10.
- (i) $\frac{1}{4}$ " dia. x $1\frac{1}{2}$ " long copper electrodes. Ends should be freshly faced on lathe and sides machined lightly to a distance of $\frac{1}{2}$ " back from end.
- (j) 4" x 10" 103F and NH_3 -sensitized 1-N photographic plates
- (k) Spark discharge chamber. See Figure 7.
- (l) Wadsworth fully automatic stigmatic grating spectrograph, 21' grating, 15,000 lines per inch (Jarrell-Ash Company).
- (m) Dietert Spark unit
- (n) Dietert rocking developing machine.
- (o) Bausch and Lomb viewing box.

(5) Procedure

(Heed Health Safety Rules Outlined in Sections 8.2 and 8.3-1)

- (a) If metallic, dissolve the sample in the smallest possible quantity of constant boiling HCl and dilute to volume with quartz-distilled water in a 1 milliliter glass-stoppered pyrex volumetric flask. Examine the solution critically for un-dissolved material; if a

Figure 8
Micro-electrolytic Reduction Cell.

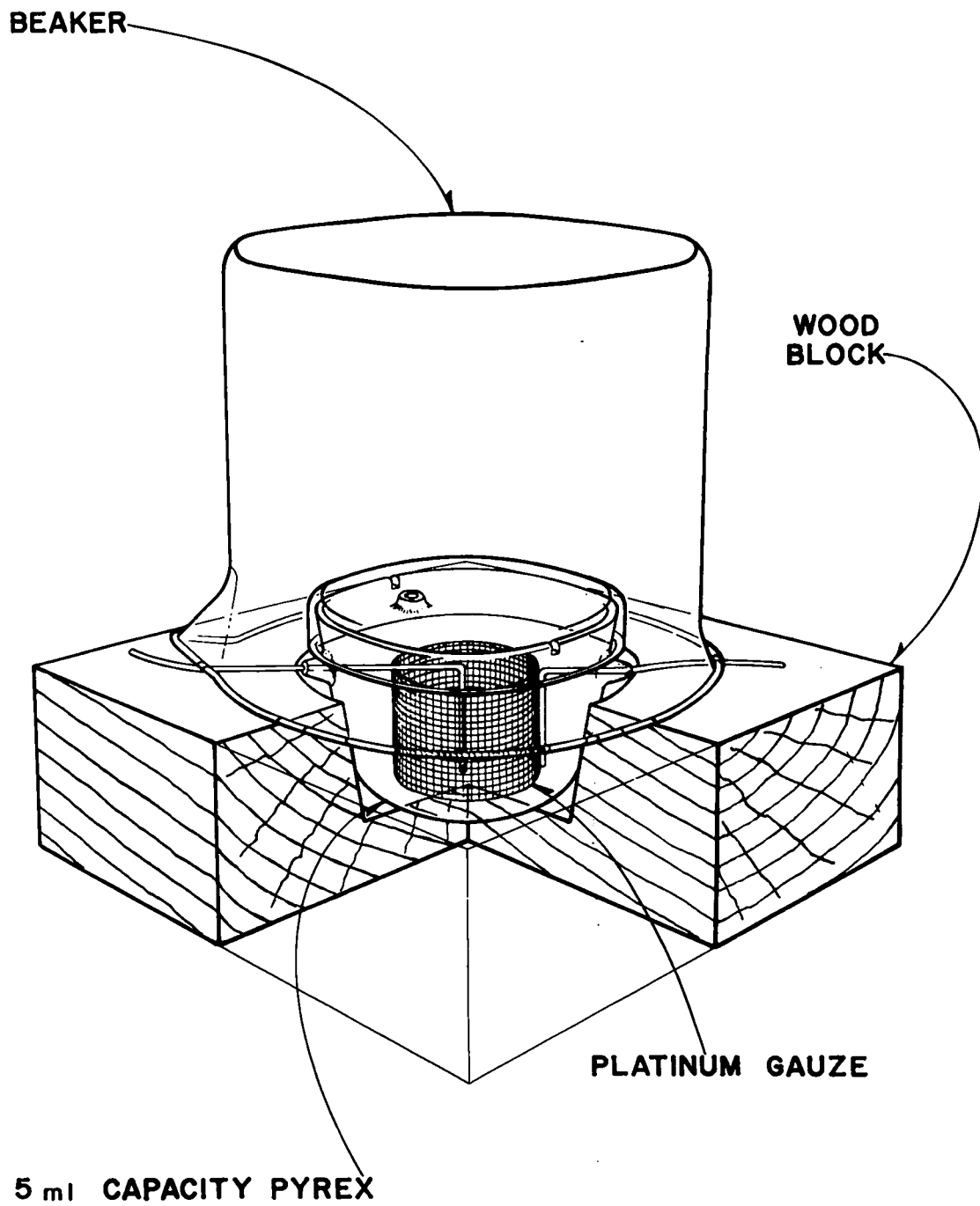

Figure 9
Infra-red Evaporator

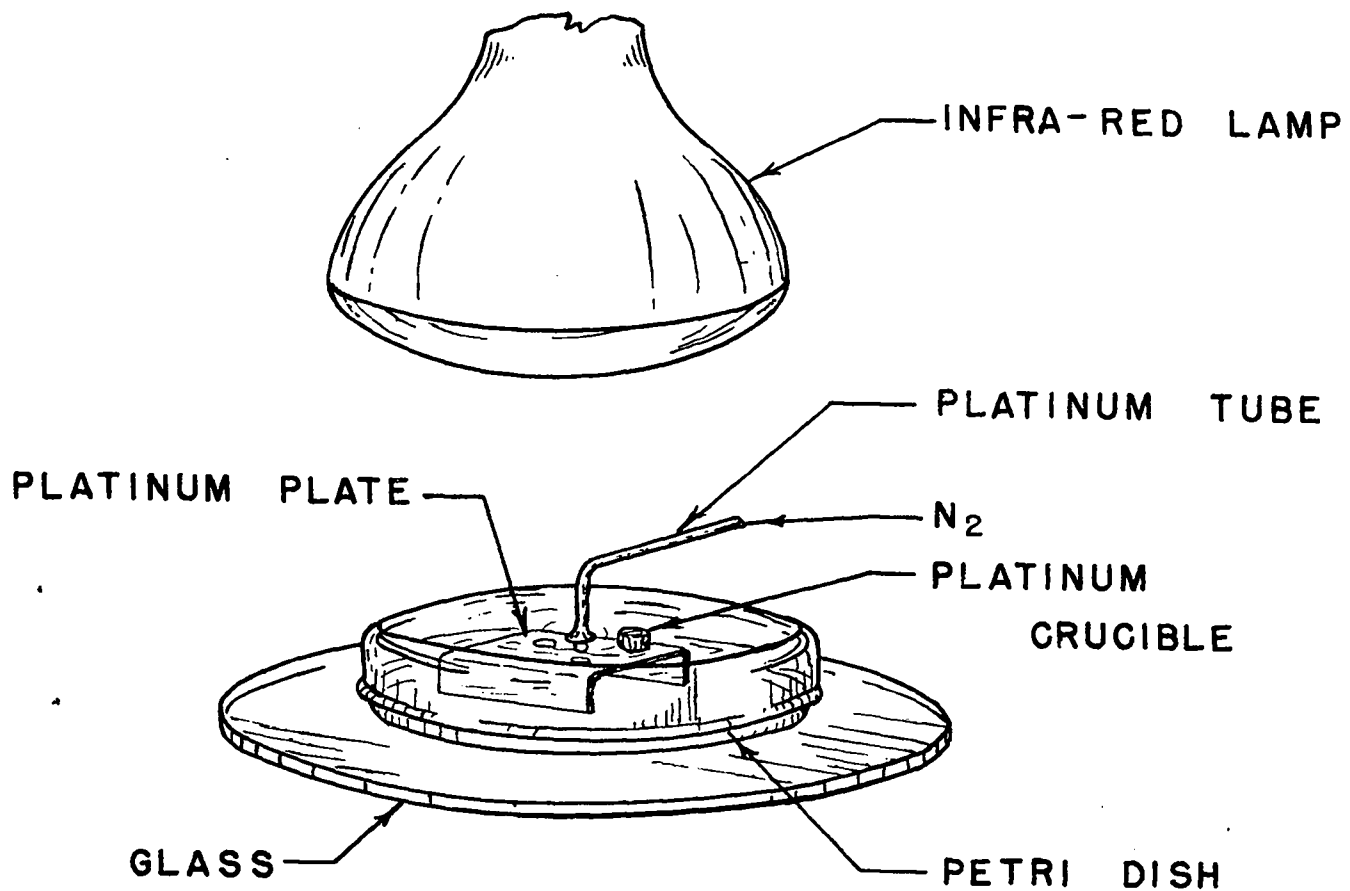

Figure 10
Electrode Evaporator

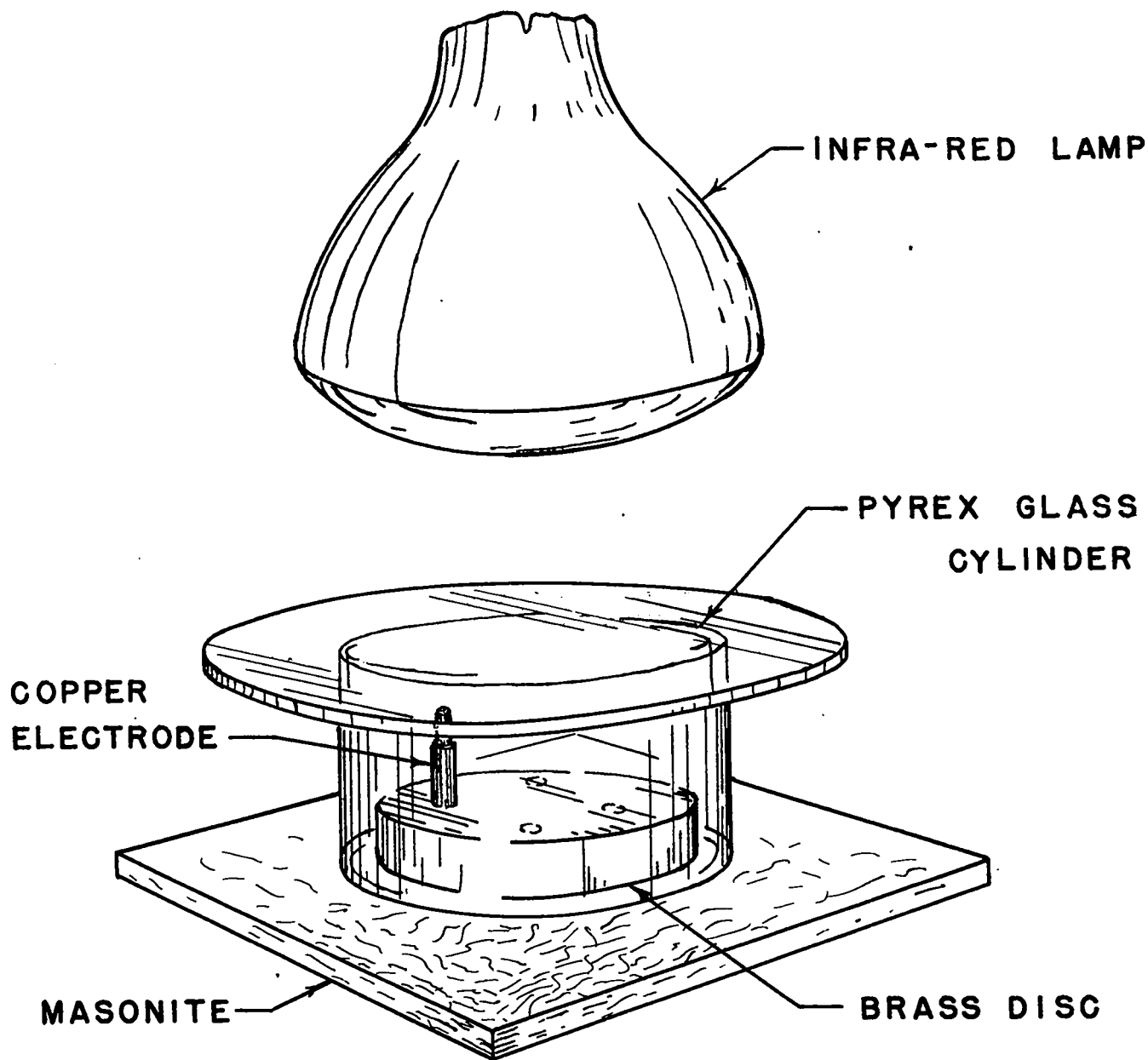
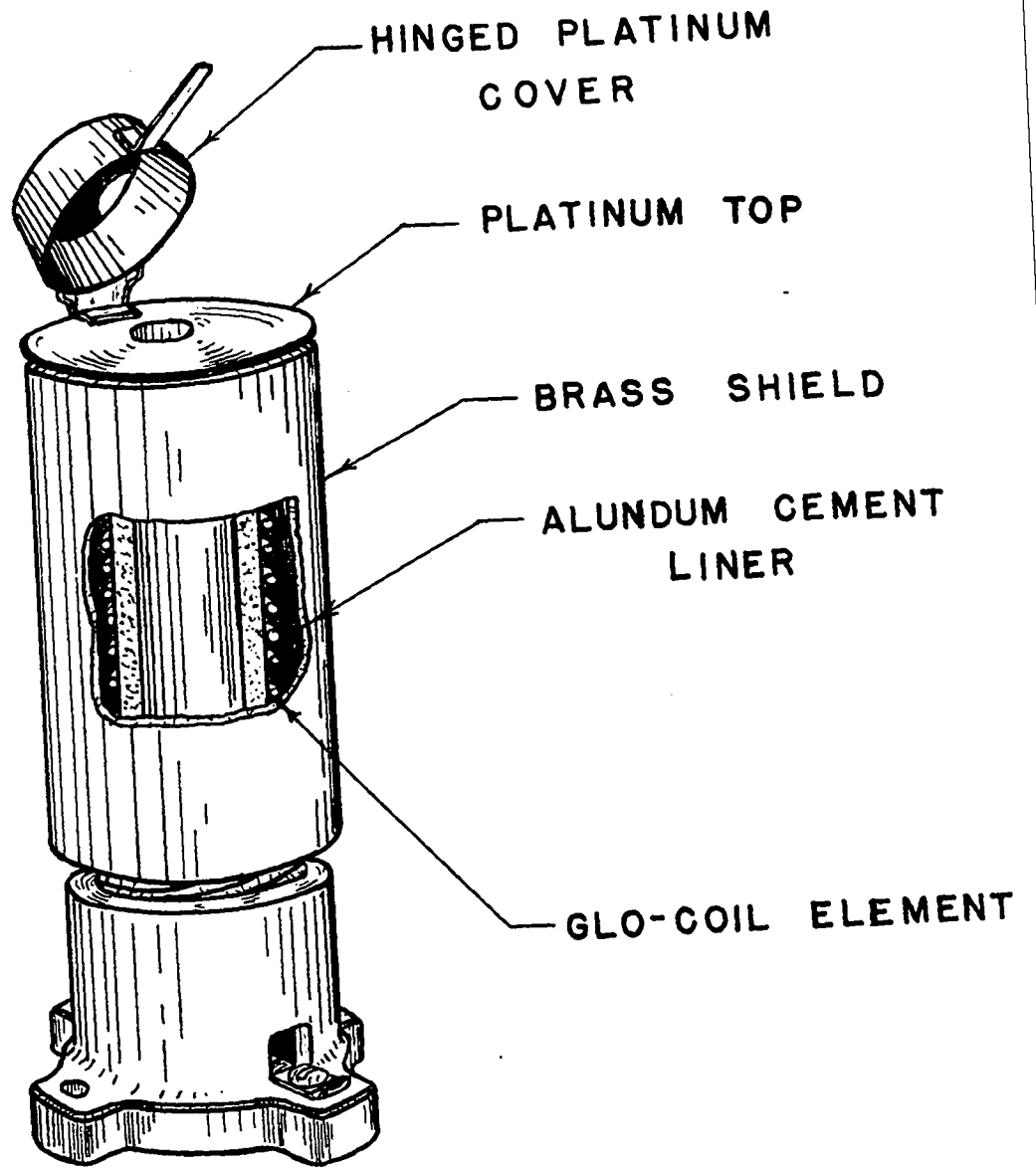

Figure 11
Cylindrical Micro-Furnace



residue is present, centrifuge it to the bottom of the flask. (1)

If the sample is in solution as +6 nitrate, reduce it to the +4 state at 1.8 volts and 15 milliamperes for 1 hour in the electrolytic cell.

- (b) If the sample is a salt, dissolve an amount equivalent to about 50 milligrams of metal in water, HCl, or HNO₃, as necessary, and dilute it to volume in a volumetric flask of adequate capacity. It may be necessary to digest the sample with these solvents or with HF in a platinum crucible under an infra-red lamp. Some oxides may resist all efforts to dissolve them, and their analysis should not be attempted by this method.
- (c) Withdraw an aliquot equivalent to about 5 milligrams of metal add 200 λ 6N HCl, dilute to 1 milliliter in a 1 milliliter glass-stoppered pyrex volumetric flask.
- (d) Prepare an ether solution of the free acid of cupferron as follows: Dissolve 1.0 g. of the ammonium salt in 10 milliliters of water in a 10 milliliter graduated cylinder equipped with a glass stopper. Add about 30 drops of constant-boiling HCl or until the free acid is precipitated to produce a permanent turbidity. Add 1 milliliter of ether and extract the free acid into the ether by shaking the cylinder.

(1) If a residue appears at this point which resists all efforts to bring it into solution with HCl, proceed with the analysis of the soluble portion. Transfer the insoluble residue to a 1 ml. platinum crucible and attempt to dissolve it with 0.1 milliliter of HF (distilled from platinum). If the residue dissolves in HF, analyze it as a separate sample according to the procedure given above. If the residue fails to dissolve in any of the mineral acids, slurry it up with a few drops of water and transfer to a copper electrode for qualitative identification.

- (e) Add 7 drops of the above ether solution per 5 milligrams of Pu to the diluted sample aliquot and shake vigorously to coagulate the plutonium cupferride. Add 0.1 milliliter of chloroform and gently invert the flask several times to dissolve the cupferride. The aqueous phase should be colorless, although it may be somewhat turbid.
- (f) Draw off the aqueous phase as carefully as possible, using a quartz-tipped syringe pipet, and transfer it to a 1 milliliter platinum crucible. Disregard the small volume of aqueous phase (about 5 per cent) which cannot be easily separated from the chloroform layer.
- (g) Evaporate the aqueous phase to dryness in the infra-red drying chamber, passing nitrogen through the petri dish to carry away the vapors. No considerable amount of undecomposed organic matter should remain at this point. Dissolve any residue which may appear by adding 0.1 milliliters of purified 16 N nitric acid and evaporate just to dryness in the infra-red drying chamber.
- (h) Dissolve the residue in 0.1 milliliter of quartz-distilled 1 N HCl. Withdraw the solution, using a 0.05 milliliter micro-pipet and coat it on a pair of copper electrodes.
- (i) Rinse the crucible with .06 milliliters of quartz-distilled 6 N HCl and add the solution to the copper electrodes.
- (j) Dry the solutions on the electrodes in the glass-covered brass electrode holder, using an infra-red lamp as the source of heat.
- (k) Prepare a series of copper electrodes bearing known quantities of Li, Be, Na, Mg, K, Al, and Ca (and such additional elements from the list as may be desired) in the range of interest (e.g. 0.001, 0.005, 0.01, 0.05 micrograms of each element).

- (1) Align the electrodes as carefully as possible in the discharge chamber, gauging the 2 millimeter electrode separation and the lateral and vertical positioning by projecting a shadow-image of the electrodes on a screen behind the chamber on the optical point.
- (m) Spark the electrodes for 50 seconds, using the Dietert spark unit, set for the following conditions: Rotary gap setting at 10; Power, 2KVA; Inductance setting at 8; Input voltage, 230; Output primary voltage, 95-100. Set the slit of the Wadsworth spectrograph for 50 microns. Always check the alignment of the electrodes before starting a run by visual examination of the spectrum of a pair of copper blanks.

Photograph the first order spectrum (2) of the following lines on two 103-0 plates:

Cd: 2288.0 Å
 Hg: 2536.5
 Mn: 2576.1
 Mg: 2795.5
 Sn: 2840.0
 Pb: 2833.1
 Be: 3130.4
 Zn: 3282.3
 Co: 3453.5
 Ni: 3493.0
 Zr: 3438.2
 Ca: 3933.7
 Al: 3961.5
 La: 3949.1
 Ce: 4012.4
 Sr: 4077.7
 Cr: 4254.3
 Ba: 4554.0

Photograph the following lines on a 103-F plate placed in the right side of the camera cassette (as viewed from the back of the instrument):

Na: 5890 Å
 Li: 6707.8

(2) Should only the light elements: Mg, Be, Ca, Al, Li, Na, and K be desired, use only a 1-N plate and a 103-F plate. The second order spectrum of Mg, Be, Ca, and Al will appear on these plates along with the lines of the alkali metals.

Photograph the K: 7664.9 line on an ammonia-sensitized 1-N⁽³⁾ plate placed in the left side of the camera cassette (as viewed from the back of the instrument).

(3) To sensitize the plate immerse it in a 4 per cent ammonia solution (by volume) for one minute at a temperature not exceeding 10°C. Transfer the plate to a tray containing methanol at 10°C for one minute. Dry the plate as rapidly as possible in a stream of cold air. Plates sensitized in this manner are extremely susceptible to fogging, and the operations must be carried out in absolute darkness. The keeping qualities of sensitized plates are poor; they may be kept in a refrigerator, but should be used within 48 hours.

- (n) Develop both 103F and 1-N plates in total darkness for 3 minutes at 18.0° C in Eastman D-19, using rocking development. Fix in F-5 for 10 minutes after immersion in an acetic acid short stop for about 10 seconds. Wash plates in a vertical stream of water for 10 minutes, rinse in distilled water and dry out of contact with dust after removal of most of the water with a moist vicose sponge.
- (o) Examine the spectra on a viewing box, comparing the line densities of the sample spectra with those of the standards photographed on the same plate. Subtract the quantity appearing in the spectrum of the procedure blank from that appearing in the sample spectra for each element of interest.
- (p) References

The development of the method described is covered in the following project reports:

CK-738	LAMS-72	LAMS-176
CK-801	LAMS-86	LAMS-190
CK-877	LAMS-97	LAMS-211
CK-928	LAMS-109	LAMS-217
CK-993	LAMS-122	LAMS-234
CK-1064	LAMS-127	LAMS-249
CK-1229	LAMS-146	LAMS-276
CK-1326	LAMS-155	LA-387 (Terminal Report)

8.3-4 Spectrochemical Determination of Light-Element Impurities in Plutonium Metal and Compounds by the Copper Spark-Gallic Acid-Aniline Method

(1) Abstract

Tri- or tetra-valent plutonium nitrate or chloride is separated from Li, Na, Mg, K, and Ca by formation of an insoluble compound with gallic acid and aniline which is selectively wetted by aniline. The aqueous phase, containing the light-element impurities, is evaporated on copper electrodes, which are then sparked to produce the impurity spectrum. Comparison of the densities of the impurity lines with standard spectra permits estimates of the amounts of impurities present.

(2) Applicability

This method has been applied also to uranium and uranium-plutonium-alloys

(3) Limits of Sensitivity

(Based upon analysis of 5 milligrams of metal)

<u>Element</u>	<u>ppm</u> <u>first order</u>	<u>ppm</u> <u>second order</u>
Li	1.0	
Na	5.	
Mg	1.	3.
Ca	1.	10.
K	20.	

(4) Reagents

- (a) Constant-boiling HCl, distilled from and stored in quartz vessels.
- (b) Diluted quartz-distilled HCl, prepared by diluting 1 milliliter of c.b. HCl to 5 milliliters with quartz-distilled water.
- (c) Purified gallic acid solution (7.5 milligrams per milliliter). See section 8.10.
- (d) Aniline, distilled from quartz and stored in red pyrex vessels.
- (e) Quartz-distilled water.

34

- (f) Quartz-distilled HNO_3 .
 - (g) Platinum-distilled HF .
- (4) Apparatus and Materials
- (a) Electrolytic reduction cell. See Figure 8.
 - (b) 1 milliliter quartz centrifuge cones
 - (c) 10 and 50 micro-liter quartz pipets.
 - (d) 1 milliliter platinum crucible.
 - (e) Infra-red evaporating apparatus. See Figure 9.
 - (f) Electrode evaporator. See Figure 10.
 - (g) Cylindrical micro-furnace. See Figure 11.
 - (h) 4" x 10" 103F and NH_3 -sensitized I-N photographic plates.
 - (i) $\frac{1}{4}$ " dia. x $1\frac{1}{2}$ " long copper electrodes. Ends should be freshly faced on lathe and sides machined lightly to a distance of $\frac{1}{2}$ " back from end.
 - (j) Spark discharge chamber. See Figure 7.
 - (k) Wadsworth fully automatic stigmatic grating spectrograph, 21' grating, 15,000 lines per inch (Jarrell-Ash Co.).
 - (l) Dietert spark unit.
 - (m) Dietert rocking developing machine
 - (n) Rausch and Lomb viewing box.
 - (o) International clinical centrifuge.
- (5) Procedure

(Heed Health Safety Rules Outlined Above)

- (a) If metallic, dissolve the sample (\approx 50 milligrams, if available) in the smallest possible quantity of constant boiling HCl and dilute to volume with quartz-distilled water in a 1 milliliter glass-stoppered

pyrex volumetric flask. Examine the solution critically for undissolved material: if a residue is present, centrifuge it to the bottom of the flask. Withdraw most of the supernatant solution with a pipet and wash the residue into a 1 milliliter platinum crucible. Digest the residue with a small quantity of platinum-distilled HF, and when the solution is clear, fume it down several times with quartz-distilled HCl or HNO_3 to dispel the fluoride. Combine the solution of the residue and the solution first obtained and adjust to a convenient definite volume.

- (b) If the sample is a compound, dissolve an amount equivalent to about 50 milligrams of metal in water, HCl or HNO_3 , as necessary, and dilute it to volume in a volumetric flask of adequate capacity. It may be necessary to digest the sample with these solvents or with HF in a platinum crucible under an infra-red lamp. Some oxides may resist all efforts to dissolve them, and their analysis should not be attempted by this method.
- (c) If the sample is received in solution, have its concentration determined by assay methods and dilute it to give a concentration of about 50 mg. per milliliter. In any case, if the valence state is $+6$, reduce it to the $+4$ state at 1.8 volts (~ 15 milliamperes for one hour in the electro-reduction cell).
- (d) Withdraw an aliquot equivalent to about 10 mg. of metal and transfer it to a 1 milliliter platinum crucible. Evaporate the solution to dryness to expel excess acids. Be careful to avoid overheating in the latter stages of evaporation to prevent formation of an insoluble residue. Dissolve the salt residue (preferably $+4$ nitrate) in about 150 micro-liters of quartz-distilled water and

36

transfer the solution to a 1 milliliter quartz centrifuge cone. Add about 50 microliters of gallic acid solution (7.5 mg. per ml.) and about 15 micro-liters of aniline. A precipitate should form. Stir with a length of platinum wire which has been cleaned by ignition. Centrifuge the precipitate to the bottom of the cone. Test for completeness of precipitation by adding another 50 micro-liters of gallic acid solution. If a precipitate again forms, add another 15 micro-liters of aniline, stir, and centrifuge. Continue testing for completeness of precipitation in this manner, omitting, however, further additions of aniline. If care has not been taken to remove the excess acid it will not be possible to remove the plutonium completely from solution. A final pH of 2 is considered to be satisfactory, and the amount of plutonium remaining in the aqueous phase will then be less than 50 micrograms.

- (e) Carefully withdraw the aqueous layer from the cone by means of a quartz pipet; the volume should be between 300 and 500 micro-liters. Transfer the solution to a 1 milliliter platinum crucible and evaporate it to dryness under an infra-red lamp. Burn off the residue of gallic acid in a cylindrical micro-furnace. Dissolve the residue in 50 micro-liters of HCl (1 part of c.b. acid diluted with 4 parts of water). Rinse the crucible by transferring it back and forth with a quartz pipet.
- (f) Divide the solution into two equal fractions and evaporate each fraction on a pair of copper electrodes in the infra-red electrode evaporator. (This requires four copper electrodes, each bearing about one fourth of the sample impurities; if desired, the solution may be divided between only two electrodes, using clean blank copper electrodes to oppose the coated ones in the spark).

- (g) Prepare a series of copper electrodes bearing known quantities of Li, Na, Mg, K, and Ca in the range of interest (e.g., 0.001, 0.005, 0.01, and 0.05 micrograms of each element).
- (h) Set the Dietert spark unit to give the following conditions: power in-put, 2 KVA; inductance, 8; in-put voltage, 230; rotary gap, 10; primary voltage, 95-100. Set the timer relay for an exposure of 60 seconds. Close the slit of the Wadsworth spectrograph to 50 microns. Insert a pair of copper electrodes into the holders in the discharge chamber, and align them laterally and vertically at a separation of 2 millimeters by projecting their shadow-image on the alignment screen on the optical axis behind the chamber. Strike a spark between the electrodes and open the spectrograph shutter. Remove the camera from the back of the instrument and observe the full-height spectrum in the visible region with a hand lens through the camera port. This is a check on the electrode alignment and should reveal the tall lines as uniformly bright along their length. Set the Hartmann diaphragm to give lines 2 millimeters tall and load the camera. Put a 103-F plate in the right hand side of the camera and an NH₃-sensitized I-N plate in the left hand side. Set the camera to photograph the range, 5500 Å - 8000 Å.
- (i) Insert the standard electrode pairs and sample electrode pairs in the discharge chamber in turn, passing nitrogen through the chamber for one minute. Stop the flow of nitrogen, open the spectrograph shutter and strike the discharge. Rack the plate up 3 millimeters after each 60 second exposure. Spark the sample or samples about mid-way between the first and last standard.
- (j) Develop the plates in total darkness for 3 minutes at 18.0° C.

in Eastman D-19, using rocking development. Fix in F-5 for 10 minutes after immersion in an acetic acid short stop for about 10 seconds. Wash plates in a vertical stream of water for 10 minutes, rinse in distilled water, and dry out of contact with dust after removal of most of the water with a moist viscose sponge.

- (k) Examine the plates on a viewing box or in the modified Judd-Lewis plate comparator. Use the following lines:

Mg: 2795.5 Å	2nd order
Na: 5890.0	
Na: 5896.0	
Li: 6103.6	
Li: 6707.8	
Ca: 3933.7	2nd order
Ca: 3968.5	2nd order
K : 7664.9	
K : 7699.0	

Compare the line densities of the sample spectra with those of the standards photographed on the same plate. Subtract the quantity of each element appearing in the reagent blank from the quantity of that element appearing in the sample.

(6) References

The development of the method described is covered in the following project reports:

CC-937	LAMS-86
CK-1148	LAMS-97
CK-1374	LAMS-109
LAMS-72	LAMS-122

8.3-5 Spectrochemical Estimation of Fluorine in Uranium and Calcium Metals

(1) Abstract

Fluorine is liberated from the sample as HF by H_2SO_4 or $HClO_4$. The HF is distilled and then converted to NaF by absorption in NaOH. The NaF is arced in the presence of excess SrO and the amount of fluorine is estimated by comparing the intensity of the SrF band heads at 5771.9, 5774.8, and 5779.5 Å with the intensity of the same band heads from a suitably prepared standard.

(2) Applicability

The method has been used primarily for uranium metal but is applicable, presumably, to other materials which are soluble in non-volatile acids without loss of F. The limit of sensitivity is 0.5% F.

(3) Method of Sampling

A representative section of the interior of the piece of uranium is cut to size that will fit the electrolytic cell. A section measuring about 4 x 4 x 20 millimeters and weighing about 6 grams is suitable for the cell illustrated (Figure 13). Smaller sections may be used.

(4) Reagents

- (a) 71 per cent HNO_3 .
- (b) 96 per cent H_2SO_4 , F free (See Blank Procedure).
- (c) 30 per cent H_2SO_4 , " " " "
- (d) 70 per cent $HClO_4$, " " " "
- (e) 30 per cent H_2O_2 , Superoxol, Merck, "F free".

40

- (f) 0.1 N NaOH, F free
 - (g) SrO, F free
 - (h) NaF stock solution containing 1 milligram F per milliliter
 - (i) Nitrazine paper, Squibb
- (5) Apparatus and Materials
- (a) Electrolytic cell (Figure 13) with storage battery, voltmeter, ammeter, and variable resistance, or a unit containing a variable D.C. source with necessary controls and meters.
 - (b) Platinum distillation cell and metal heating block. See Figure 12.
 - (c) Hot plate and Variac.
 - (d) 2-liter syphon bottle to maintain reduced pressure on absorption side of distillation cell. It is provided with a stopcock or clamp to adjust flow rate.
 - (e) Safety trap to keep pressure within the required limits. (Figure 12).
 - (f) 10 milliliter platinum evaporating dish
 - (g) Platinum crucibles, 3-5 milliliter capacity
 - (h) 1/8" diameter steel drill and bakelite guide for forming craters on electrodes. See Figure 14.
 - (i) 1/8" diameter spectrographic graphite rod and 1/4" diameter graphite rod.
 - (j) Ten 1/4" i.d. heating coils mounted on an insulating board -- Variac control. See Figure 15.
 - (k) Electrode holder
 - (l) λ pipet control and λ pipets of capacity 10, 20, 50, and 100 λ .
 - (m) 4" x 10" 103a-T or 103a-D Eastman-Kodak spectrographic plates.
 - (n) Eastman D-19 developer, F-5 fixer, acetic acid short stop.

Figure 12

Distillation Apparatus

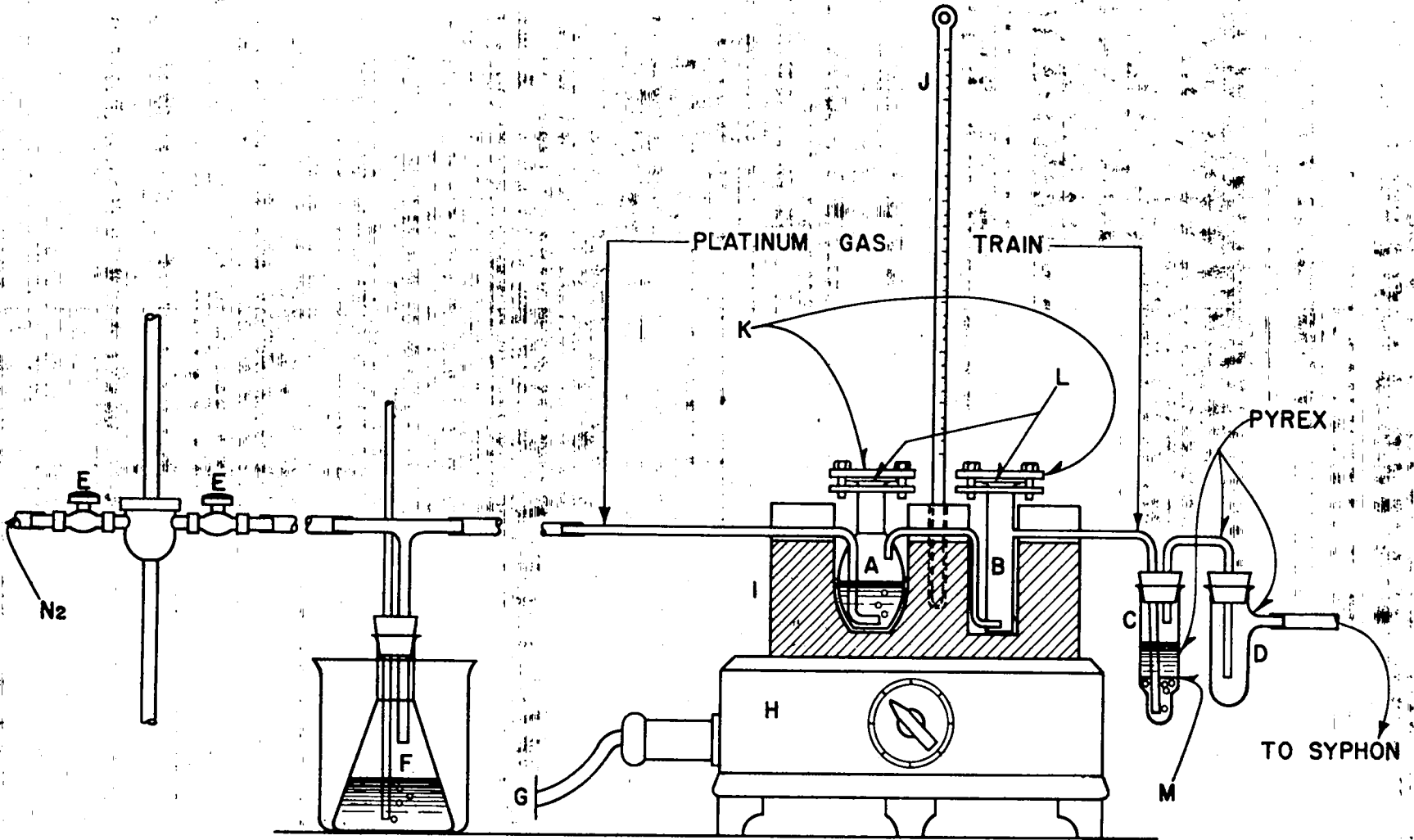

Figure 13
Electrolytic Cell

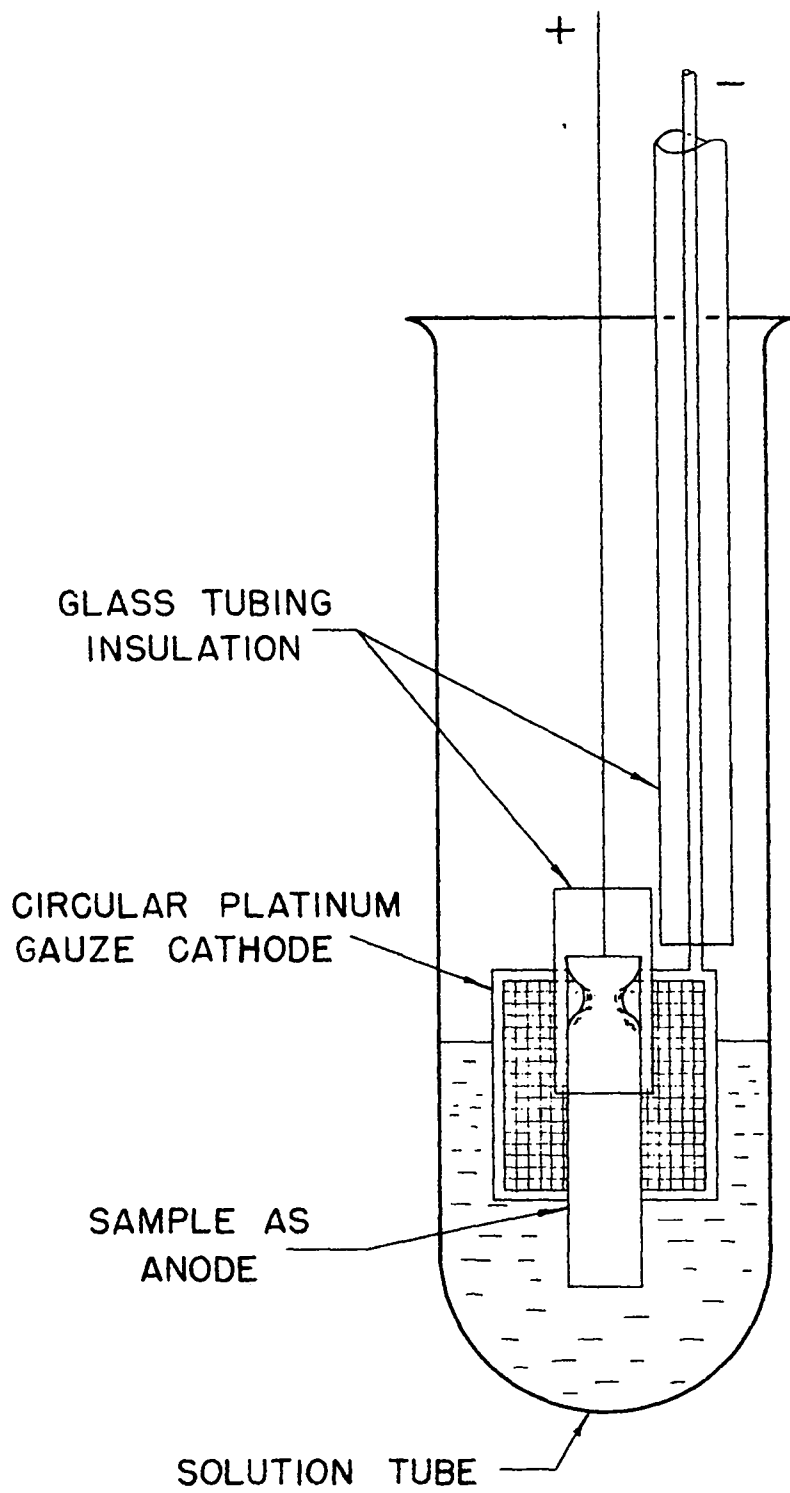

Figure 14

A - Electrode Assembly

B - Crater forming Apparatus.

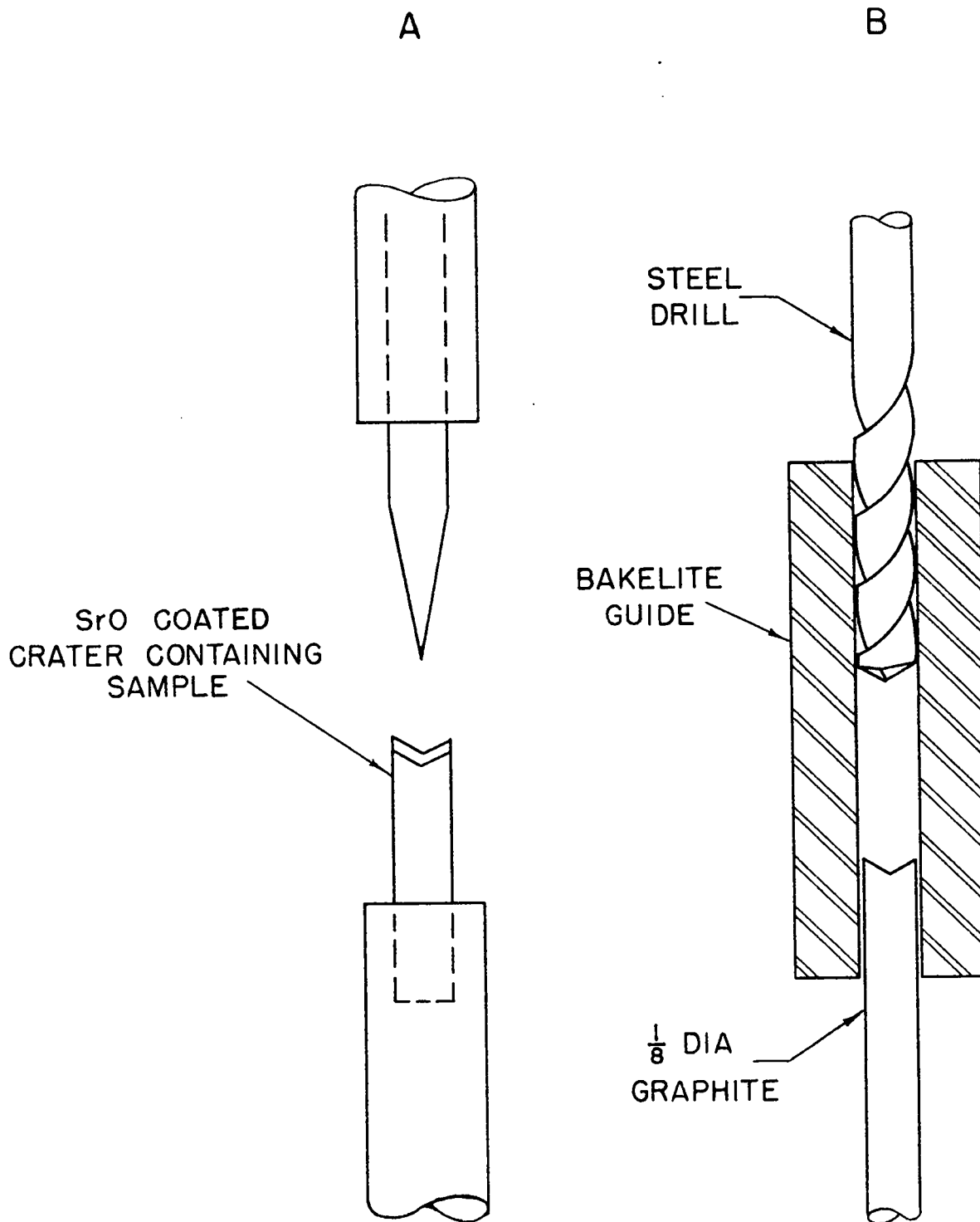
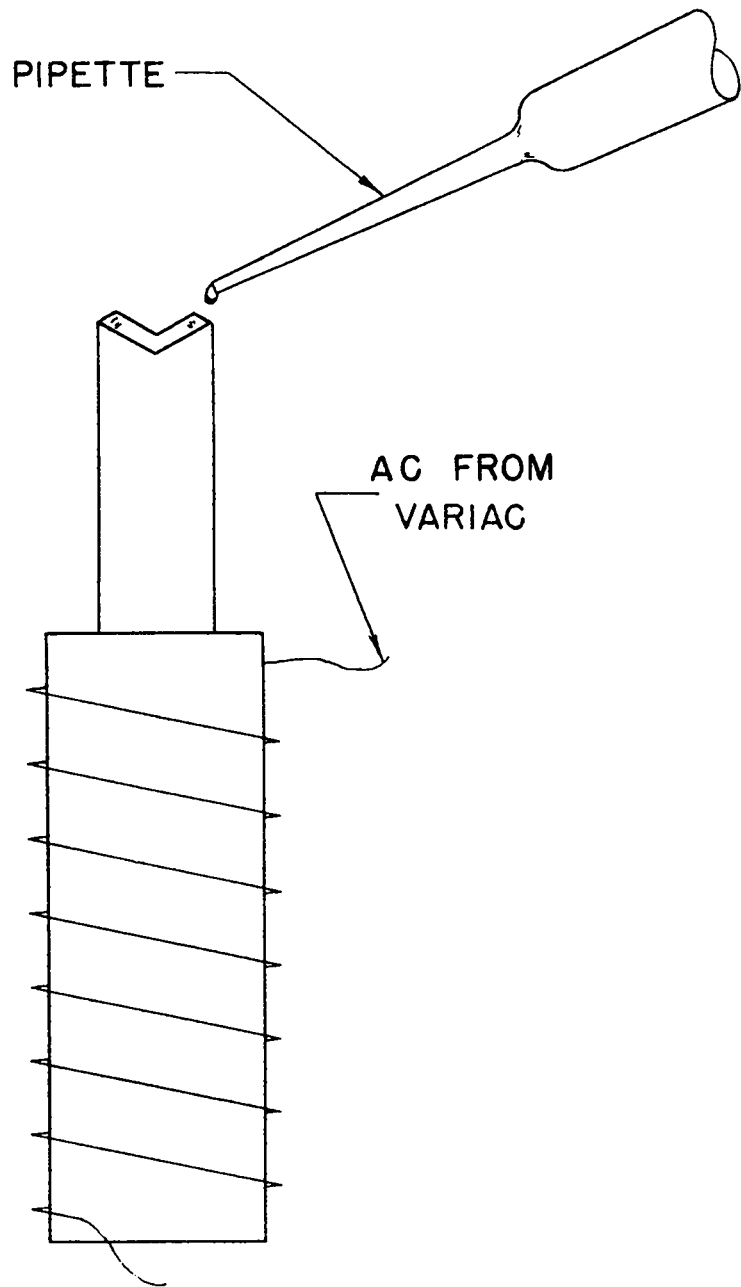

Figure 15
Detail of a Heating Coil



(6) Procedure I (for uranium)

- (a) File small notches near one end of the uranium sample so that it can be fastened firmly with good electrical contact to the center electrode (Figure 13). If the sample has a smooth metallic surface, pickle it in conc. HNO_3 long enough to remove the oxide coating. If it contains cavities or has a rough surface, pickle it somewhat longer until slag is dissolved and the surface has a metallic appearance. Rinse well with distilled water, allow to dry on filter paper, and weigh to the nearest 10 milligrams.
- (b) Attach sample firmly to the center electrode (Figure 13). Connect this electrode to the positive terminal and the platinum gauze electrode to the negative terminal. With the electrolytic cell immersed in a beaker of cold water, electrolyze at 0.2 - 0.6 amperes into 2.5 milliliters of 30 per cent H_2SO_4 until 0.5 grams of uranium has been oxidized from the metal sample. If a duplicate is being run and the approximate F content is known, electrolyze enough to give 1 - 5 Y F. With a current of 0.4 amperes, 0.5 grams will be electrolyzed in about one-half hour. The $\text{U}(\text{SO}_4)_2$ precipitate in this case will fill the cell to about one-third the original depth of 30 per cent H_2SO_4 . Remove the cooling bath and lower the solution tube. Remove the uranium metal from the center electrode, transfer any appreciable adhering precipitate to the solution, rinse the metal (discarding rinsings), dry on filter paper and weigh.
- (c) Add 400 μ of 30 per cent H_2O_2 to the solution in the tube. Immerse the gauze electrode in the solution until all adhering precipitate is dissolved. Drain the solution from the electrode

into the tube. Discard rinsings. Mix the solution and precipitate by occasional swirling until all the precipitate is dissolved.

- (d) Add 50 λ of 0.1 NaOH to the pyrex cup C (Figure 12). Place a small piece (1/8" x 1/4") of nitrazine indicator paper in the cup. Add enough water so that the surface just touches the platinum gauze retainer. Assemble the cup.
- (e) Add the solution prepared in step (c) to chamber A. Add 1.5 milliliters of 96 per cent H_2SO_4 . Assemble the gas line to the syphon and open the stopcock on the latter so that 1 or 2 bubbles per second pass through the base in C. Screw down tightly the caps on chambers A and B (B need not be opened between distillations) and assemble the pressure side of the gas line. Before applying pressure, test the line for leaks by running the syphon at about 6 milliliters per minute (2 or 3 drops per second) and observe if air bubbles pass through the safety trap at a steady rate comparable with the rate of flow through C. If they do not, there is probably a leak at one of the caps of the distillation cell. If no gas bubbles through C, either the lead is stopped or there is a leak in the line to the syphon. With the needle valves closed and with air flowing at the proper rate (1 or 2 bubbles per second) into the safety trap, gradually turn on the nitrogen at the tank to about 1 pound per square inch. Open the small needle valves, E, until only an occasional air bubble passes through the tube into the safety trap. With these conditions a pressure about 1 centimeter of water below atmospheric pressure will be maintained within the distillation cell. Also the nitrogen (with maximum allowable pressure de-

terminated by the height of the tube in the safety trap) will prevent gases or solution of samples from backing up, into the pressure lines.

- (f) Raise the temperature of the heating block (See Precaution 9a) from 100°C to 160° C over a period of 1 hour during which much of the water and some of the HF distills over. The rise in temperature is best controlled by setting the thermo - state on the hot plate to a desired maximum and adjusting the rate of temperature rise by making the proper voltage setting on the Variac. Maintain the heating block at 160° C for 1½ hours and the gas flow at 6 milliliters per minute (Precaution 9b). If the base should be neutralized (blue to yellow) at any time during distillation, add another 50 λ portion (Precaution 9c). Increase nitrogen pressure slightly before opening cup C so that absorbing solution will not be drawn back into chamber B. Also see that any base solution in platinum lead is forced into C after distillation is complete.
- (g) Transfer the basic solution containing the distillate to a small platinum crucible or dish and concentrate it to a volume of 50 λ . If the F content is unpredictable, concentrate one-tenth and nine-tenths of the solution separately and arc these aliquots on separate electrodes.
- (h) Rinse the distillation cell for the next determination by drawing tap water and finally distilled water through it in the reverse direction. Use a trap if this is done either with the mouth or the vacuum line.
- (i) Form craters in the electrodes by inserting 1/8" diameter spectrographic graphite rod into one end of the bakelite

48

- sleeve and a 1/8" steel drill into the other end (See Figure 14). A few hand turns of the drill with light pressure will form a crater. Break off 3/4" cratered lengths.
- (j) Make graphite electrode bases from 1/4" diameter rod. This can be done on a lathe. Use a size drill which will permit a neat fit for the cratered lengths. These bases can be used repeatedly.
- (k) Make upper electrodes as shown in Figure 14.
- (l) Place as many electrodes in the heater (Figure 15), as are required for distillations and standards. Weigh 1 milligram of finely divided SrO into each crater. With some practice, careful visual estimation after light tapping of the side of the electrode is adequately quantitative. With a λ pipet add enough water to moisten the SrO. Turn on the Variac at low voltage and evaporate slowly and carefully so that the SrO is not lost. Continue evaporating small portions of water from the SrO until an even coat of oxide (free from large bubbles and fragile crusts) covers the entire crater.
- (m) Prepare two standard NaF solutions from the stock solution. Dilute respectively 1 milliliter and 2 milliliters of reagent (f) to 10 milliliters. Prepare fresh standard solutions every 3 days until a solution of a particular concentration has stood in its containing vessel for several weeks. Thereafter, fresh standards need not be prepared.
- (n) Make standard electrodes carrying 1 γ , 2 γ , 4 γ , and 8 γ F.

49

- For the 1γ standard, evaporate 10λ of the solution containing 0.1 milligrams per milliliter on a SrO coated crater as prepared in step 1. Proceed similarly with the other standards and distillate concentrates. Evaporation must not be so rapid as to cause loss of SrO and NaF by spattering. Add the solution in small portions to the edge of the oxide coating. It will spread rapidly over the crater and not creep back along the outside of the pipet. If necessary draw out the tip of the pipet or wax it lightly with a high melting wax.
- (o) In total darkness load the right side of the Wadsworth camera with a 4" x 10" 103a-T (or 103a-D) plate, emulsion side down (i.e. facing the grating). With necessary precautions against fogging of the plate, attach the camera to the camera carriage of the Wadsworth, draw down the plate shield and clamp it into position.
- (p) Turn on the Dietert D.C. source. Set the amperage at a minimum (about 3 amperes with this arc) by turning the hand-crank to the counter-clockwise stop. Set the automatic timer at 60 sec. Set the polarity switch at positive for lower electrode. Adjust the slit height to 2 millimeters and the slit width to 30μ (3 on the micrometer's scale). Raise the camera carriage to a reading of 30 millimeters and position the wavelength to $5000 - 6300\text{ \AA}$ on the short wavelength half. Place in front of the slit a filter which transmits wavelengths of 5000 \AA and greater. Set the front edge of the base of the cage at 40.7 centimeters on the scale and clamp the 90 millimeters spherical quartz lens with its base

against that of the cage so that an enlarged (3-fold) image of the arc will be focused on the slit.

- (q) Clamp a cratered electrode (containing SrO only, in the lower holder and a pointed one in the upper holder (Figure 14). Close the cage door. With an electrode separation of about 5 millimeters strike the arc with a graphite rod mounted in an insulating handle. Raise the upper electrode to a separation of 10 millimeters and adjust the electrodes (laterally and vertically) so that the slit is in the upper side of the arc image (Figure 16). Mark the position of the electrode image on the screen behind the cage. Turn off the arc.
- (r) Replace the SrO blank electrode with a standard or sample and adjust the crater to the same position using the shadow cast on the screen by the small lamp in front of the lens. Open the shutter, strike the arc as in (q) and raise the upper electrode to 10 millimeter separation. As the electrodes burn away maintain them at this position. If the SrO should volatilize completely in less than 60 seconds close the shutter and turn off the arc. After each exposure close the shutter and raise the camera carriage 3 millimeters.
- (s) Develop the plate in total darkness for 4 minutes at 18°C in Eastman D-19 using rocking development. Immerse the plate for 10 seconds in an acetic acid short stop. Fix it in F-5 for 10 minutes or until the silver halide is completely dissolved. Wash the plate in running water for 10-20 minutes and rinse it with distilled water. Remove excess water from the plate with a sponge and dry it out of contact with dust.
- (t) Compare (visually on a plate viewer with the aid of a lens) the samples with the standards. The band heads at 5771.9.

Figure 16
Arc Image (Inverted)

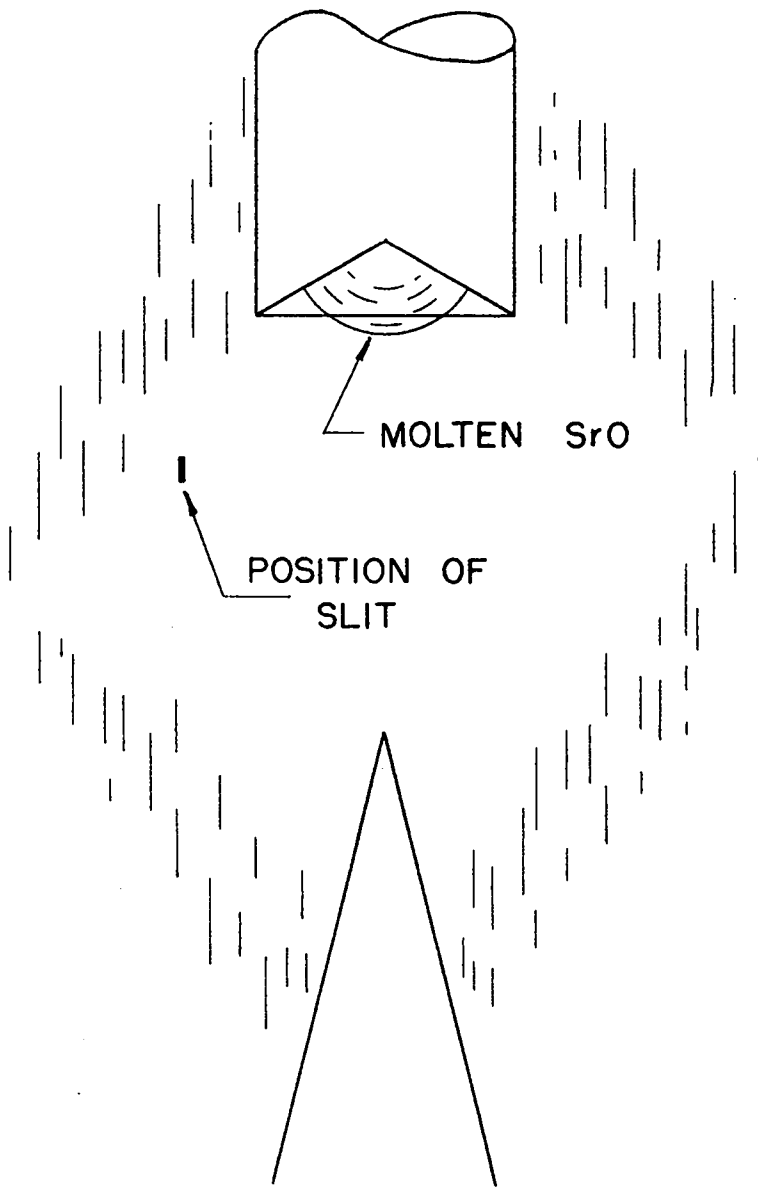

5774.8 and 5779.5 Å are used. With uniform excitation conditions and equal amounts of SrO the backgrounds should be the same for each exposure. Under normal conditions estimation of fluorine by comparison can be made to 40 per cent or better. If the background is not the same for each exposure, make an allowance for the variation.

(7) Procedure II (for calcium)

The conditions stated under Applicability must be met for any particular sample. For Ca metal the following modifications are made:

- (a) Place the Ca metal (about 1 gram) in a 10 milliliter platinum evaporating dish and cover it with a watch glass. Add water dropwise through the lip until the sample is completely oxidized. Neutralize with 70 per cent HClO_4 just to the yellow color of the nitrazine indicator. Ca(OH)_2 dissolves completely. Add 0.1 N NaOH dropwise — one drop beyond the appearance of the blue color of the indicator. Evaporate the solution to about half this volume or until the salt crystallizes out when allowed to cool.
- (b) add 100 μ 0.1 N NaOH to cup C and follow Procedure I, (d).
- (c) Transfer the warm concentrated solution of step (a) to chamber A. Rinse the evaporating dish with 2 milliliters 70 per cent HClO_4 and transfer the rinsings to chamber A. Assemble and test the gas line as in Procedure I, (e).
- (d) Follow Procedure I, (f) with these exceptions. Use a distillation temperature of 170°C instead of 160°C. If the base in cup C is not neutralized during distillation, follow procedure I, (g)-(t)

- (e) If the base is neutralized (Precaution 9a), add 1 milliliter of 0.1 N NaOH to cup C and continue distillation. The volatile acid is most probably HCl.
- (f) To test for Cl^- , acidify a small portion of distillate with HClO_4 and add AgClO_4 . Return the test solution to the distillate and proceed as follows: If Cl^- is present neutralize the entire distillate with HClO_4 and add 0.5 milliliters of 1 N HClO_4 in excess. Transfer to a centrifuge cone of twice the volume. Add 0.1 N AgClO_4 in 100 λ portions, mixing and centrifuging after each addition until further addition of AgClO_4 no longer precipitates AgCl.
- (g) Follow Procedure I, (d),
- (h) Empty and rinse the distillation cell. Decant the clear solution of step (f) and transfer it to Chamber A. Add 2 milliliters 96 per cent H_2SO_4 . Assemble and test gas line as in Procedure I, (e). Follow Procedure I, (f) - (t).
- (8) Blank Procedure

Establish the absence of F (to limit of sensitivity) in all the reagents by performing the entire procedure without a sample. A small ($< 1\%F$) but reproducible blanks may be tolerated in which case this value is subtracted from the plate estimation of F.

(9) Precautions

- (a) Adequate heating of distillation cell is essential. The leads between chambers A, B, and C must be maintained at such a temperature that water will not condense in them; otherwise distillation will not be smooth and recovery may not be complete. If contact between heating block and cell is not

satisfactory, a wax or oil bath may be used.

- (b) Establishment of quantitative recovery of known amounts of F must be done by any one operator. If conditions as given in Procedure I, (f) are not sufficient they will have to be altered accordingly. This applies equally to all modifications.
- (b) Neutralization of the base is caused either by acid spray from chambers A and B or by distillation of volatile acids; it is the latter, if the sample has an unexpectedly high F⁻ content, or has Cl⁻, NO₃⁻ etc. in excess of 0.005 milliequivalents (See Procedure II).

(10) Literature References

Petrey, A. W. , Ind. Eng. Chem., Anal. Ed. 6, 343 (1934).

Ahrens, L. P., S. African J. Sci. 39, 98 (1943).

Project Reports:

LAMS-86
LAMS-97
LAMS-109
LAMS-122

8.3-6 Spectrochemical Determination of Impurities in Uranium Metal and Compounds by the Gallium Oxide-Pyroelectric Method

(1) Abstract

The uranium metal or compound is converted to U₃O₈ by ignition in air. A 100 milligram sample of the resulting oxide containing 2 per cent of gallium oxide is arced from the crater of a graphite electrode in a direct current arc. The complex spectrum of uranium does not appear. The quantity of impurities present is estimated by comparison of the densities of their spectrum lines with the corresponding lines of standard spectra.

(2) Sensitivity, Precision, and Applicability

Following is a list of elements determinable in U₃O₈ according

to the pyroelectric method, together with their sensitivities of detection. Sensitivities are reported in parts per million on the basis of 98 milligrams of U_3O_8 analyzed. In general the precision is good to 20 per cent of the amount reported.

It should be emphasized that the limits of sensitivity listed relate to impurities present in oxide. Impurities in metal or salt samples may be determined only if such impurities are not lost in burning the metal or salt to oxide. Boron and silicon in fluoride and mercury in metal are, for example, not determinable by this procedure.

<u>Element</u> ⁽⁴⁾	<u>Sensitivity (ppm)</u>
Li	0.2
Be	0.05
B	0.05
Na	5

(4) Sc, Ge, Se, Rb, Sr, Y, Te, Cs, Ba, Ru, Rh, W, Re, Os, Ir, Pt, Tl not investigated.

Mg	1
Al	5
Si	2
P	50
K	40
Ca	20
Ti ⁽⁵⁾	--
V	20
Cr	5
Mn	1
Fe ⁽⁵⁾	--
Co	1
Ni	1
Cu	0.5
Zn	20
As	5
Zr ⁽⁵⁾	--
Cb ⁽⁵⁾	--
Mo	1
Pd	1
Ag	0.05
Cd	0.05
In	0.2
Sn	1

Sb	5
Rare Earths (5)	--
Ta (5)	--
Au	0.05
Hg	1
Pb	1
Bi	0.2
Th (5)	--

(5) Unsatisfactory by pyroelectric method

(3) Reagents

- (a) Purified gallium sesquioxide, Ga_2O_3 . See Section 8.10-3.
- (b) Purified uranium oxide, U_3O_8 . (6)

(6)

Place several hundred grams of uranyl nitrate hexahydrate (Mallinckrodt) in a 1 liter separatory funnel and add about 500 milliliters of anhydrous ether (Merck). Separate the ether layer from the water layer and re-extract the nitrate into quartz-distilled water. Add enough nitric acid to prevent formation of the insoluble orange compound on evaporation. Evaporate the solution to crystals of uranyl nitrate hexahydrate. Remove as much water and nitric acid as is possible without formation of the insoluble salt. Repeat the ether extraction and the above steps twice. Finally, ignite the resulting salt to U_3O_8 in a muffle furnace. See also section 8.10-3.

-
- (c) LiF , BeO , B_2O_3 , NaCl , MgO , Al_2O_3 , SiO_2 , $\text{Ca}_3(\text{PO}_4)_2$, KCl , V_2O_5 , Cr_2O_3 , MnO_2 , Fe_2O_3 , Co_2O_3 , Ni_3O_4 , CuO , ZnO , As_2O_3 , MoO_3 , Ag_2O , CdO , In_2O_3 , SnO , Sb_2O_3 , Au_2O_3 , PdCl_2 , HgO , PbO , Bi_2O_3 , c.p. reagent grades.

(4) Apparatus and Materials

- (a) Tungsten carbide mortar and pestle.
- (b) Pin vise and needle
- (c) Platinum crucibles (18 milliliter capacity).
- (d) A.R.L. graphite electrode cutter.
- (e) Special spectroscopic graphite electrodes, available from National Carbon Co.
- (f) Watch-glasses (4 centimeters) with off-center holes. See

Figure 17.

- (g) Mini-mill, available from Fisher Scientific Co.
- (h) 2" x 2" 45° quartz prism in adjustable mounting. See Figure 18.
- (i) 35 millimeter SA1 film.
- (j) 4" x 10" 103-F and NH₃-sensitized I-N photographic plates.
- (k) Bakelite electrode holders. See Figure 19.

(5) Procedure

- (a) Prepare 5 grams of a U₃O₈ standard containing 1000 ppm of each of the metals in the following salts and oxides: LiF, BeO, B₂O₃, NaCl, MgO, Al₂O₃, SiO₂, Ca₃(PO₄)₂·KCl, V₂O₅, Cr₂O₃, MnO₂, Fe₂O₃, Co₂O₃, Ni₃O₄, CuO, As₂O₃, ZnO, MoO₃, Ag₂O, CdO, In₂O₃, SnO, Sb₂O₃, Au₂C₃, PdCl₂, HgO, PbO, and Bi₂C₃. Grind the above compounds thoroughly into the U₃O₈ in a tungsten carbide mortar, and mill the mixture on the Mini-mill. Prepare a standard containing 500 ppm. of each of the same metals by grinding 2.50 grams of the first standard with 2.50 grams of pure U₃O₈. Mill the mixture as before. In similar fashion, prepare succeeding standards so that the following ppm are available: 1000, 500, 200, 100, 50, 20, 10, 5, 2, 1, 0.5, 0.2, 0.1, 0.05 and blank.
- (b) If the sample is metallic, convert it to U₃O₈ by ignition in platinum in air. A Meker burner provides adequate heat for the operation. Salts which may be converted to U₃O₈ by ignition in air should be so converted before proceeding with the analysis.

Figure 17
Watch Glass with Off-center Hole.

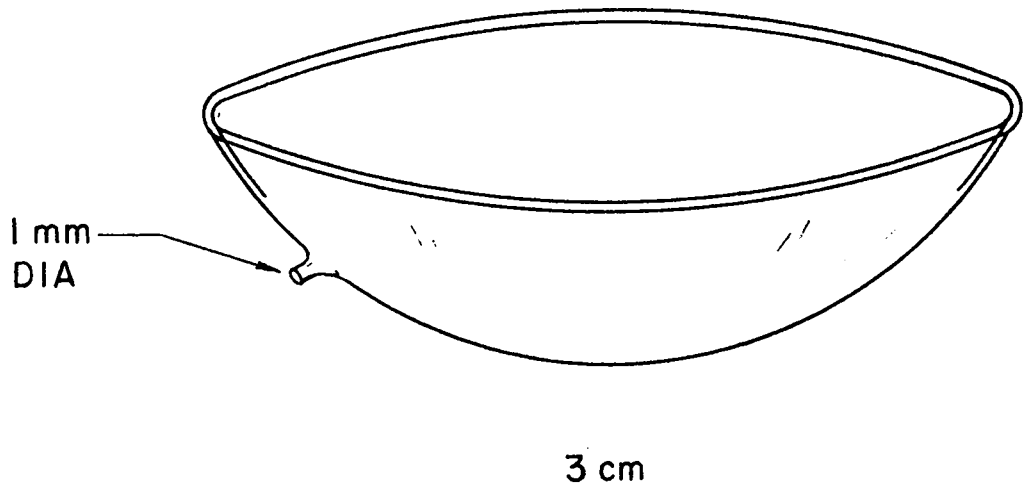

''

Figure 18
Optical Alignment of Spectrographs

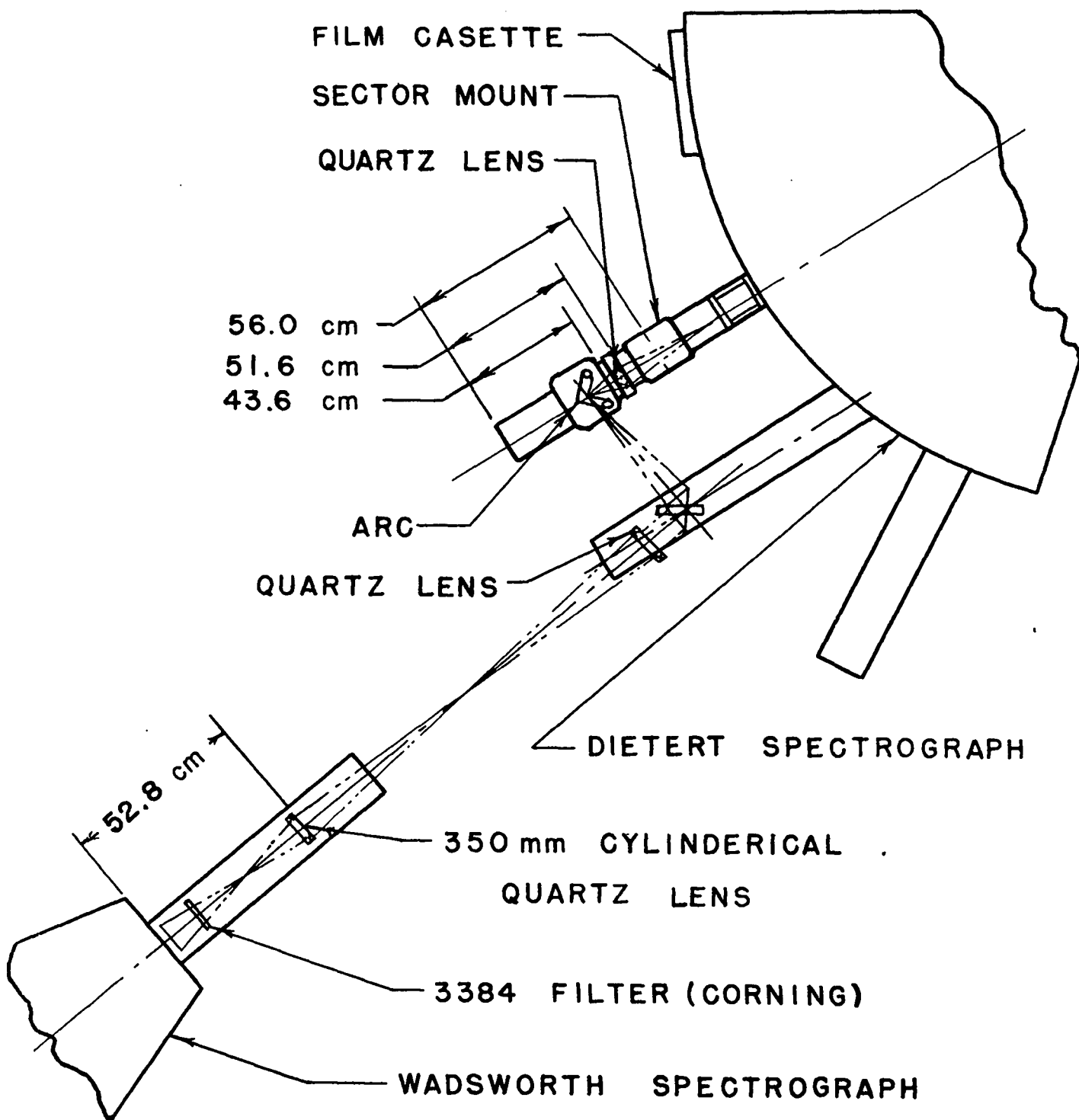

Figure 19
Bakelite Electrode Holder

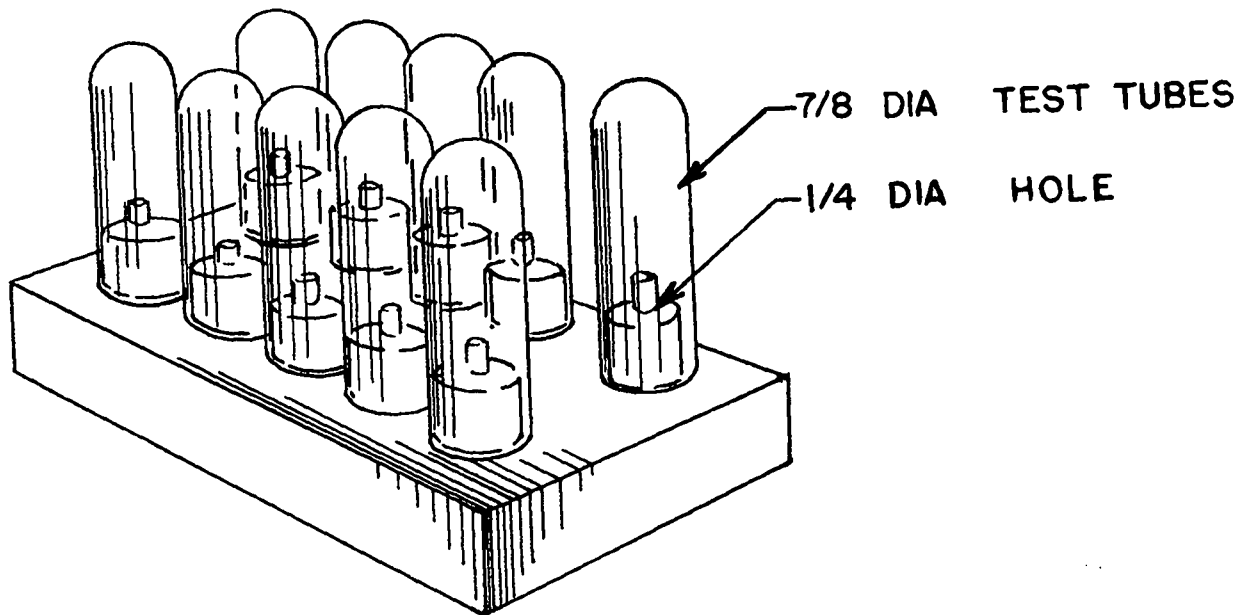
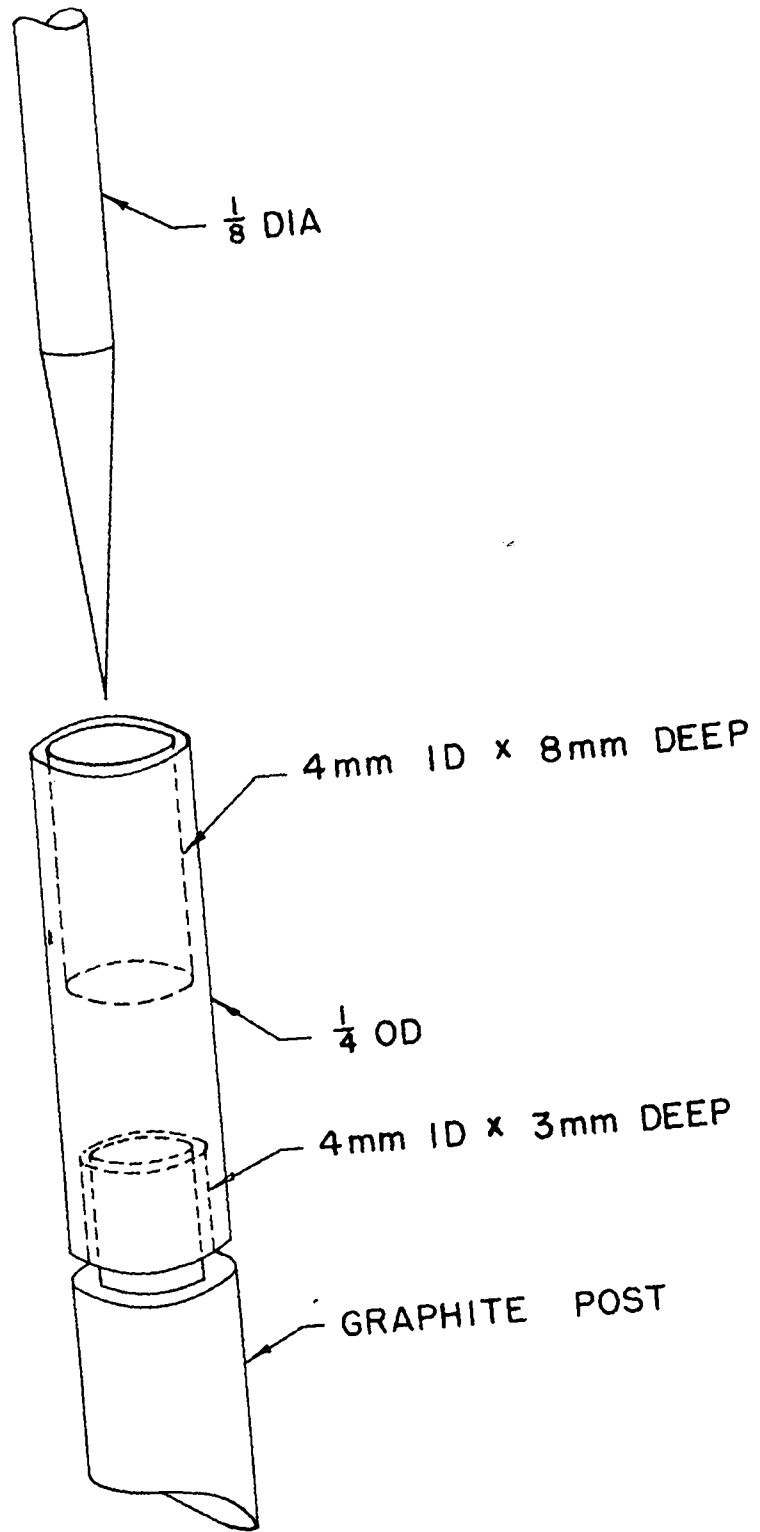

Figure 20
Graphite Electrode Dimensions



- (c) Weigh out 8.0 milligrams of gallium sesquioxide as accurately as possible on a tared watch glass pierced with an off-center hole. On the same watch glass weigh out 392 milligrams of the U_3O_8 blank. Transfer the whole to a tungsten carbide mortar and grind the gallium oxide thoroughly into the uranium oxide.
- (d) Prepare a number of 1/4" and 1/8" graphite electrodes to the dimensions shown in Figure 20. Pre-burn the electrodes at 13.5 amperes d.c. for 30 seconds to remove surface contamination. Weigh out 100 milligrams of the uranium oxide-gallium oxide blank mixture and transfer it to the 8 millimeter deep crater of one of the pre-arced electrodes. Similarly, grind all of the other standards with gallium oxide and load electrodes with 100 milligram charges.
- (e) Tap each electrode on a hard surface to compact the sample at the bottom of the crater. Push a needle, held in a pin vise, through the charge and into the graphite at the bottom of the crater. Tap the electrode again and withdraw the needle with a rotary motion.
- (f) Adjust the Dietert Arc Unit to give a current of 13.5 amperes on closed circuit with graphite electrodes in place. Place a pointed 1/8" diameter electrode in the upper electrode holder and a graphite post in the lower holder. Place the electrode bearing the uranium oxide-gallium oxide blank on the lower post and align the electrodes laterally and vertically at a separation of 4 millimeters by back-projection of their shadow images on the alignment screen. Check the polarity of the arc, making the lower electrode the anode.

- (g) Place the 2" quartz prism on its table on the 2nd optical bench of the Dietert and the 3" quartz lens in its place in front of the prism. Their positions should be determined previously, so that a beam of light is sent into the Wadsworth spectrograph. Close the slit of the Wadsworth spectrograph to a width of 50 microns and adjust its height to 2 millimeters with the Hartmann diaphragm. Place a 103-F plate in the right hand side of the camera cassette and an NH_3 -sensitized I-N plate in the left hand side (as viewed from the rear of the instrument). Set the camera to photograph the range, 5300 Å - 7800 Å. Check the Dietert camera to make certain it contains film.
- (h) Open the slit of the Dietert spectrograph to a width of 20 microns and bring the No. 2 diaphragm in position at the secondary focal point. Open the spectrograph shutters and strike the arc. Continue the exposure during the pre-silent and silent periods, extinguishing the arc when it begins to sputter.
- (i) Pack up the cameras of both spectrographs and repeat the arcing procedure for the remaining standards. By arcing the weaker standards first the danger of contamination of succeeding samples is reduced. Develop both film and plates for 3 minutes at 18.0° C in Eastman D-19, using rocking development. Place film in 0.5 per cent acetic acid short stop for 10 seconds. Fix the film in F-5 for 3 minutes and the plates for 10 minutes. Rinse in distilled water and dry out of contact with dust after removal of most of the excess water with a moist viscose sponge.
- (j) Bind the film between frames cut from 1/16 inch Lucite so

that it may be used as a master plate in the Dietert densitometer. The plates should be left unbound, for use on the viewing box.

- (k) Prepare and arc samples in exactly the same way. All samples should be run in duplicate and a standard sample should be arced on each film and plate to reveal abnormalities which may arise in the procedure.

(6) Evaluation and Expression of Results

To evaluate a film place it in the film jig in the densitometer and insert the master film in the master plate slide. Compare the standard spectrum with the corresponding standard spectrum on the master film. If the line densities agree for all of the elements of interest, proceed to compare the lines of the sample spectra with the corresponding lines on the master plate, noting the concentrations for which the densities are equal. If necessary, interpolate the sample lines' densities into the standard series of spectra. If the standard spectrum fails to agree with the corresponding spectrum on the master plate, look for a density match with one of the other master spectra. Provided the disagreement is not greater than a factor of two and provided the standard spectrum's gallium lines and general background compare with those of the sample spectra, the evaluation may still be made. In this case, employ the factor necessary to make the standard spectrum agree with the corresponding master plate spectrum in reporting results in ppm.

(7) Alternative Procedure

An arrangement by means of which the complete spectrum (2250 - 7100 Å) of a sample may be obtained in a single exposure using only one spectrograph is described in Project Report IA-257.

(8) References

This method was developed by the National Bureau of Standards.

Additional information is contained in the following reports:

A-128	LAMS-122
A-129	LAMS-127
A-194	LAMS-146
A-1076	LAMS-155
A-2907	LAMS-176
CC-240	LAMS-190
CK-801	LAMS-211
CK-928	LAMS-217
CK-993	LAMS-254
LAMS-97	LAMS-249
LAMS-109	LAMS-257

LAMS-266

B.3-7 Spectrochemical Determination of Impurities in Magnesium Oxide and Calcium Oxide

(1) Abstract

5 milligram samples of finely ground MgO or CaO are weighed into 2.5 millimeter deep craters of 1/4 inch diameter graphite electrodes and arced at 13.5 amperes for 2½ minutes. A rotating sector, adjusted to transmit 40 per cent of light is employed to prevent excessive background. Comparison of the densities of the impurity lines with standard spectra permits estimates of the amounts of impurities present.

(2) Sensitivity and Precision

Following is a list of the elements determinable by the method described, together with corresponding sensitivities of detection.

The precision is estimated to be \pm 50 per cent, average deviation from the mean.

<u>Element</u>	<u>Sensitivity (ppm)</u>	
	<u>MgO</u>	<u>CaO</u>
Be	1	1
B	20	10(7)
Mg	—	?

(7)

No grade of CaC sufficiently free of Mg was found.

Al	20	20
Si	50	50
Ca	10	—
V	—	50
Cr	20	—
Mn	5	10
Fe	10	—
Ni	—	50
Co	—	50
Cu	—	10
Mo	100	50
Ag	—	1
Cd	—	50
In	—	50
Sn	20	10
Sb	—	50
Au	—	10
Pb	20	10
Bi	10	10

(3) Procedure

See IA Report 416.

8.3-8 Spectrochemical Determination of the Rare Earth Elements In Uranium Metal and Compounds

(1) Abstract

The rare-earth elements are separated from uranium and its compounds by means of an ether extraction of the uranium, precipitation of the rare earths as fluorides, and purification of the latter by way of the hydroxides. The final determination is carried out spectrographically, using a Jarrell-Ash-Wadsworth Spectrograph and an A.R.L.-Dietert Multi-Source Unit.

(2) Sensitivity and Precision

Following is a list of elements which have been determined by the procedure described, together with their sensitivities of detection. In general the precision is about 20 per cent deviation from the correct values; usually, results are low by about this amount.

<u>Element</u>	<u>Micrograms</u>	<u>ppm (10 g. sample)</u>
Dy	0.05	.005
Gd	0.05	.005
Sm	0.50	.050
Nd	0.20	.020
Pr	0.10	.010
La	0.01	.001
Ce	0.10	.010

(3) Procedure

See British Report BM-325, also LAMS-98 and LA-416.

8.3-9 Spectrochemical Determination of Impurities in Plutonium Metal and Compounds by the Gallium Oxide-Pyroelectric Method

(1) Abstract

The plutonium metal or compound is converted to oxide by ignition in air in a dry box. A 25 milligram sample of the resulting oxide is ground with 2 milligrams of gallium oxide and 73 milligrams of purest uranium oxide (U_3O_8). The mixture is arced in a dry box from the crater of a graphite electrode in a direct current arc. The complex spectra of uranium and plutonium do not appear. The quantities of impurities present are estimated by comparison of the densities of their spectrum lines with the corresponding lines of standard spectra or by photometry, using internal standards.

(2) Sensitivity, Precision and Applicability

Following is a list of elements determinable in plutonium oxide according to the pyroelectric method, together with corresponding sensitivities of detection. Sensitivities are reported in parts

per million on the on the basis of 25 milligrams of oxide analysed. The precision averages about 9 per cent (average deviation from the mean).

It should be emphasized that the limits of sensitivity listed relate to impurities present in oxide. Impurities in metal or compounds may be determined only if such impurities are not lost during the conversion to oxide. Boron and silicon in plutonium tetrafluoride and mercury in metal are, for example, not determinable by this procedure.

In addition, only those compounds which may be converted to essentially pure oxide (PuO_2) may be analysed. Residues high in sodium (e.g., from the ignition of sodium plutonyl acetate) are not amenable to pyroelectric analysis.

<u>Element</u>	<u>Sensitivity (ppm)</u> (visual comparison)
Be	<6
B	<6
Mg	15
Al	300
Si	50
Ca	60
P	500
V	600
Ge	0
Cr	30
Mn	15
Fe	30
Co	30
Ni	60
Cu	<6
Zn	150
As	150
Pd	300
Ag	<6
In	15
Sn	20
Sb	30
Hg	15
Pb	15

(3) Reagents

- (a) Purified gallium sesquioxide, Ga_2O_3 . See Section 8.10-3.
- (b) Purified uranium oxide U_3O_8 . See section 8.10-3.
- (c) BeO , B_2O_3 , MgO , Al_2O_3 , SiO_2 , $\text{Ca}_3(\text{PO}_4)_2$, V_2O_5 , GeO_2 , Cr_2O_3 , MnO_2 , Fe_2O_3 , Co_2O_3 , Ni_3O_4 , CuO , ZnO , As_2O_3 , PdCl_2 , Ag_2O , In_2O_3 , SnO , Sb_2O_3 , HgO , PbO , c.p. reagent grades.

(4) Apparatus and Materials

- (a) Combination dry box for preparing and arcing samples. See Figures 3, 4, and 23.
- (b) Pin vise and steel needle.
- (c) Platinum crucibles (1 milliliter capacity).
- (d) A.R.L. graphite and electrode cutter.
- (e) Special spectroscopic graphite electrodes, available from National Carbon Co.
- (f) Arc stand for dry box. See Figure 21.
- (g) Watch glasses (4 centimeters) with off-center holes. See Figure 17.
- (h) Mini-mill, available from Fisher Scientific Co.
- (i) 103-aF film.
- (j) Bakelite electrode holders. See Figure 19.
- (k) Tight-fitting dust respirator.
- (l) 1st-surface aluminized plane mirror in mounting for optical bench. See Figure 22.

(5) Procedure

- (a) Prepare 5 grams of a U_3O_8 standard containing 1000 ppm of each of the metals in the following salts and oxides: BeO , B_2O_3 , MgO , Al_2O_3 , SiO_2 , $\text{Ca}_3(\text{PO}_4)_2$, V_2O_5 , GeO_2 , Cr_2O_3 , MnO_2 ,

Figure 21
Arc Stand for Dry Box

APPROVED FOR PUBLIC RELEASE

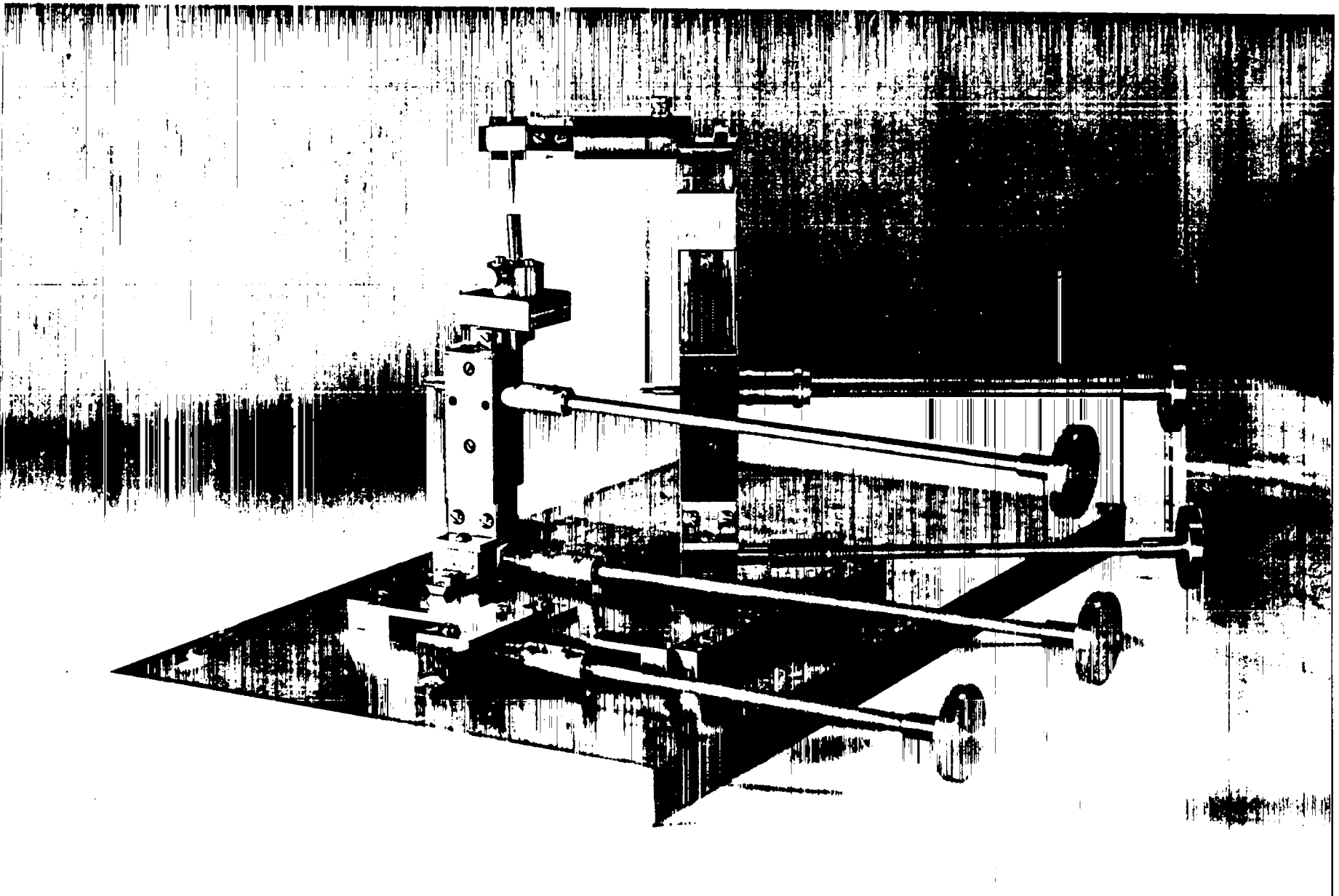

APPROVED FOR PUBLIC RELEASE

Figure 22
Aluminized Plane Mirror

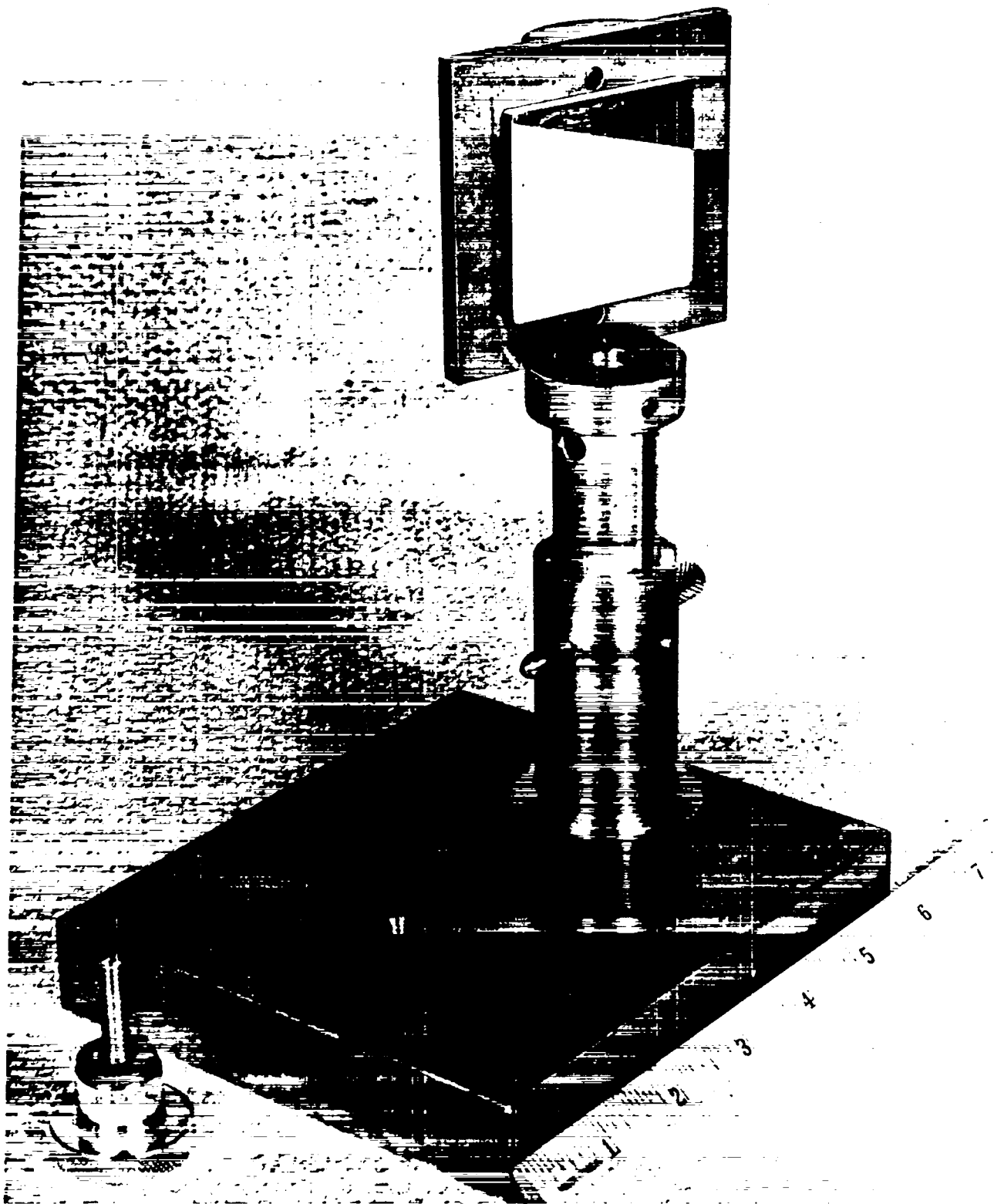

ORDER No. **34-97**
Please order reprints
by the
above number.

Figure 23
Arrangement for Arcing Plutonium Oxide

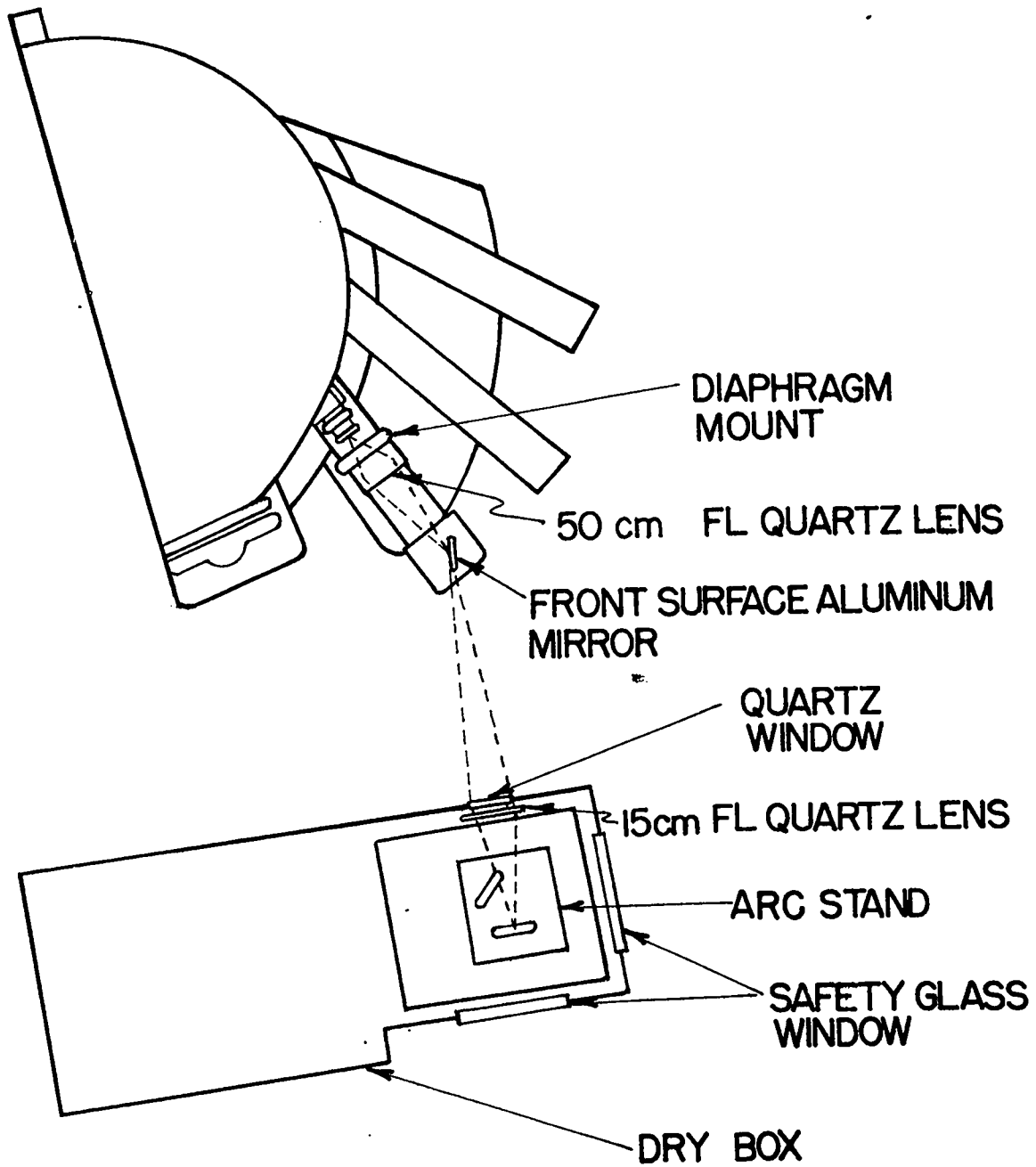

73

Fe_2O_3 , Co_2C_3 , Ni_3O_4 , CuO , ZnO , As_2O_3 , PdCl_2 , Ag_2O , In_2O_3 , SnO , Sb_2O_3 , HgO , and PbO . Grind the above compounds thoroughly into enough U_3O_8 to bring the total weight to 5 grams. Use a tungsten carbide mortar and pestle for the grinding, and mill the mixture on the Mini-mill. Prepare a standard containing 500 ppm of each of the same metals by grinding 2.50 grams of the first standard with 2.50 grams of pure U_3O_8 . Mill the mixture as before. In similar fashion, prepare succeeding standards so that the following are available (ppm): 1000, 500, 200, 100, 50, 20, 10, 5, 2, 1, and blank. The foregoing operations may all be carried out without fear of danger to the analyst. Succeeding operations must be carried out in the dry box by an operator wearing a full laboratory smock, rubber gloves, and a well-fitting dust respirator. Read "Special Health Safety Precautions to be Observed in Spectrochemical Analysis of Plutonium Metal and its Compounds" (section 8.3-1) under "Pyroelectric Method" before continuing.

(b) Grind together 2 milligrams of gallium sesquioxide⁽⁸⁾ and 25

(8)

If beryllium is not to be determined, and if spectra are to be evaluated by the internal standard procedure (part (j)-2. below), the gallium oxide should be first ground with Bi_2O_3 , BeO , Au_2O_3 , and MoO_3 in amounts to give a mixture containing 8 micrograms of Bi, 6.8 micrograms of Be, 0.8 micrograms of Au, and 40 micrograms of Mo in each 2 milligrams of gallium oxide.

milligrams of pure plutonium dioxide with 73 milligrams of each of the standards prepared above. In this manner the following standards are available (ppm referred to the plutonium contained in the mixture): 3000, 1500, 600, 300, 150, 60, 30, 15, 6, 3, and blank.

- (c) If the sample is in the form of plutonium metal or alloy, transfer it to a 1 milliliter platinum crucible in the dry box and ignite it in a micro-furnace at 700-800°C until conversion to the oxide is complete. If the sample is a solution (e.g. dissolved nitrate) evaporate it to dryness under an infra-red lamp in a well-ventilated hood. Wear a plastic visor during this operation and take every precaution to minimize spray during the evaporation. Transfer the platinum crucible containing the evaporation residue to the dry box in a nest of alternately inverted beakers. Ignite the residue to oxide in a micro-furnace in the dry box.
- (d) Weigh out 6.0 milligrams of Ga_2O_3 as accurately as possible on a tared watch glass pierced with an off-center hole. On the same watch-glass weigh out 219 milligrams of pure U_3O_8 and 75 milligrams of the PuO_2 sample in the dry box. Grind the mixture thoroughly in a tungsten carbide mortar and divide it into three 100 milligram portions. Transfer the mixtures to 8 millimeter deep craters of preburned graphite electrodes. (See Figure 2D for dimensions of electrodes).
- (e) Tap each electrode smartly on a hard surface to compact the sample at the bottom of the crater. Push a needle, held in a pin vise, through the charge and into the graphite at the bottom of the crater. Tap the electrode again and withdraw the needle with a rotary motion.
- (f) Adjust the D.C. rectifier unit to give a current of 13.5 amperes on closed circuit with graphite electrodes in place. Put a pointed 1/8 inch diameter electrode in the upper electrode holder and a graphite post in the lower holder. Place the electrode bearing the standard blank on the lower electrode

post and align the electrodes laterally and vertically at a separation of 4 millimeters by back-projection of their shadow-images on the alignment screen. Check the polarity of the arc, making the lower electrode the anode.

- (g) Place the 1st surface aluminized mirror and its table on the optical bench of the spectrograph, making sure that its angle is such as to direct the light falling upon it centrally into the slit of the spectrograph. Insert a quartz lens (f.l. 50 centimeters) on the optical bench between the mirror and the slit at a position predetermined to focus an image of the arc upon the grating. See Figure 23. Check to insure that the slit of the spectrograph is 20 microns wide, and check the diaphragm to make certain that the No. 5 aperture is in place. Test the tension of the film in the camera to insure that it is neither slack nor under stress, and rack the camera to the No. 10 position.
- (h) (From this point on the assistance of a second operator is required. One operator must stand behind the dry box with his gloved hands inserted through the gauntlets for the purpose of removing old electrodes and inserting new ones in position. He must also strike the arc by bridging the electrode gap with a piece of clean graphite rod. The second operator must stand before the dry box and manipulate the electrode controls which issue from the front of the dry box. He must also operate the switches for extinguishing the arc, remove or insert the alignment lamp and shutter as required, and attend to the racking of the camera.)

Ignite the arc and expose from this point until the arc hisses and sputters, after having passed through a silent period. Arc succeeding standards in identical manner, proceeding from the weaker standards to the stronger ones to minimize the danger of contamination from dust produced in the arcing. (A film so run is called a "standard film".) Ordinarily, the operator should plan to run several samples in triplicate and to run one or two standards on the same film for normalizing variations from the standard film.

- (i) Develop the 103-~~AF~~ film in total darkness for 3 minutes at 18.0° C in Eastman D-19, using rocking development. Fix the film for 3 minutes in Eastman F-5 after immersion for about 10 seconds in an acetic acid short stop. Wash the film for 5 minutes, rinse in distilled water, and dry in a current of warm air after removal of most of the excess water with a moist viscose sponge.
- (j) Bind the "standard film" between frames cut from 1/16 inch Lucite so that it may be used as a master plate in the Dietert densitometer. Evaluate the spectra on a film according to either of the following procedures:

1. Evaluation by Visual Comparison with the Standard Film

Insert the sample film in the film jig of the densitometer and the master film in the master plate guides of the instrument. Compare the standard spectrum of the sample film with the corresponding standard spectrum of the master film. If the line densities agree for all of the elements of interest,

proceed to compare the lines of the sample spectra with the corresponding lines on the master film, noting the concentrations for which the densities are equal. If necessary, interpolate the sample lines' densities into the standard series of spectra. If the standard spectrum fails to agree with the corresponding spectrum on the master film, look for a density match with one of the other standard spectra. Provided the disagreement is no greater than a factor of two, and provided the standard spectrum's gallium lines and general background compare with those of the sample spectra the evaluation may still be made. In this case, employ the factor necessary to make the standard spectrum agree with the corresponding master film spectrum in reporting the concentration of each element in ppm.

2. Evaluation by Photometry, Using an Internal Standard

Select, in general, the most sensitive lines of the elements of interest on the master film. Photometer them, together with their adjoining backgrounds, in each of the standard spectra. Select internal standard lines (Bi, Mo, Au, or Be) which lie reasonably close to the analysis lines chosen. Also try to choose for comparison the particular internal standard element which volatilizes at about the same temperature as the element being determined. Photometer the internal standard lines and their neighboring backgrounds. Convert the line and background transmission values into relative line intensity values by reference to a film calibration curve. Subtract the background intensities

from the corresponding line-plus-background intensities. Divide each background-corrected analysis line intensity value by its background-corrected internal standard line intensity value to obtain the so-called "intensity ratio". Plot logarithms of the intensity ratio against logarithms of concentration. Straight line graphs with unit slope should result.

To evaluate sample spectra, obtain the log intensity ratios of interest as described above. Refer these log ratios to the appropriate working curve and read off the concentration of the impurity from the graph. It is well to check the constancy of the working curve from time to time (on each film, if possible) by analyzing a standard sample.

An alternative procedure, used in analyzing samples in which gallium is to be determined, substitute silver chloride for gallium oxide. Standard and sample oxide mixtures are made up to contain 4 per cent silver chloride in place of 2 per cent gallium oxide. The limit of sensitivity for gallium by this procedure is about 6 ppm. Sensitivities for other impurities are essentially the same as those given above.

(6) References

LAMS-261

LAMS-288

LAMS-276

LAMS-302

See also references under Section 8.3-6 above.

8.3-10 Spectrochemical Determination of Impurities in Graphite by the Gallium Oxide--Pyroelectric Method

(1) Abstract

A 50 milligram sample of graphite containing 4 per cent of gallium oxide is arced from the crater of a graphite electrode in a direct current arc. The quantity of impurities present is estimated by comparison of the unknown spectrum with standard spectra.

(2) Sensitivity and Precision

Sensitivities given below are in parts per million on the basis of 48 milligrams of graphite analyzed. The precision is of the order of ± 20 per cent of the amount reported.

<u>Element</u>	<u>Sensitivity (First order)</u>
Ag	<1
As	50
Au	1
B	1
Be	<1
Bi	<1
Ca	10
Cd	<1
Co	<1
Cr	<1
Fe	5
Hg	10
In	<1
Li	5
Mg	5
Mn	<1
Mo	<1
Na	50(not D lines)
Ni	<1
P	~300
Pb	<1
Pd	<1
Sb	5
Si	5
Sn	1
Tl	1
V	5
Zn	20

(3) Procedure

See LA Report 416.

8.3-11 Spectrochemical Determination of Gallium in Plutonium Metal and Compounds by the Isopropyl Ether Extraction Method

(1) Abstract

Gallium is extracted as a chlorogallio acid complex from hydrochloric acid solutions by means of isopropyl ether. The complex is re-extracted into a small quantity of pure water, which is evaporated on copper electrodes together with an internal standard solution. The residue is excited in a condensed spark discharge and the quantity of gallium evaluated by photometry of the resulting photographed spectrum.

(2) Reagents

- (a) Concentrated hydrochloric acid.
- (b) Re-distilled isopropyl ether.
- (c) Distilled water

(3) Apparatus and Materials

- (a) Glass-stoppered pyrex graduated cylinder, 10 milliliters.
- (b) Glass-stoppered volumetric flask, 10 milliliters.
- (c) Copper electrodes, $\frac{1}{2}$ inch diameter by $1\frac{1}{2}$ inch long.
- (d) Electrode evaporator. (See Figure 10).
- (e) Micro-syringe and pipet tips (50 microliter capacity).
- (f) Type 103-0 Eastman photographic plates, 4 inch by 10 inch.
- (g) Spark discharge chamber. (See Figure 7).
- (h) Wadsworth fully automatic stigmatic grating spectrograph, 21 foot grating, 15,000 lines per inch (Jarrell-Ash Co.).
- (i) Dietert spark unit.

(j) Dietert rocking developing machine.

(k) Dietert Comparator-Densitometer.

(4) Procedure

Heed Health Safety Rules Outlined In Sections 8.2 and 8.3-1

(a) Dissolve a sample of gallium-plutonium alloy, weighing about 50 milligrams, in hydrochloric acid in a 10 milliliter glass-stoppered volumetric flask. Adjust the acidity to 7.25 N and make the solution up to 5 milliliters volume with acid of this concentration. (Note that allowance should be made for the consumption of hydrochloric acid in the dissolving operation. See "Microgravimetric Determination of Gallium in Plutonium-Gallium Alloys".

(b) Add 5 milliliters of isopropyl ether to the solution and shake vigorously for 20 minutes. Allow the phases to separate and transfer a 1 milliliter aliquot of the ether phase to a 10 milliliter glass-stoppered volumetric flask. Add 5 milliliters of distilled water to the volumetric flask and shake vigorously for 20 minutes to re-extract the gallium into the water. Make the water phase volume up to 10 milliliters.

(c) Withdraw, by means of a micro-pipet, a 50 micro-liter aliquot of the water phase and divide it about equally between the tips of two copper electrodes. Evaporate the solutions just to dryness on the copper electrodes by means of an electrode evaporator.

(d) Divide a 50 micro-liter portion of an internal standard solution (containing 80 micrograms of molybdenum per milliliter) between the same electrodes. Evaporate these solutions

to dryness as described above.

- (e) In similar fashion, prepare copper electrodes bearing 1.0 and 0.28 micrograms of gallium and 4 micrograms of molybdenum (duplicate pairs) by evaporation of appropriate volumes of a standard gallium chloride solution.
- (f) Insert the electrodes, by pairs, in the holders of the spark discharge chamber, gauging their 2 millimeters separation and lateral and vertical alignment by back-projection of their shadow image on a graduated screen behind the chamber.
- (g) Place a 4" x 10", 103-0 plate in the left side of the camera cassette (as viewed from the back of the spectrograph). Set the spectrograph to photograph the region, 2300 - 4700 Å. Excite the electrodes for 50 seconds in a condensed spark discharge (25,000 volts, 0.32 m H, 0.021 μ F) and photograph their spectra through a slit whose width is 25 microns.
- (h) Prepare a "standard plate" bearing the spectra of gallium in the following quantities: 1.0, 0.5, 0.2, 0.1, 0.05, 0.02, 0.01, and 0.00 micrograms. Each spectrum should contain the lines of molybdenum at 4.0 micrograms. Employ the techniques described above for electrode preparation and excitation. (The "standard" plates need be prepared only once or twice, since data obtained from them are used to construct working curves.)
- (i) Develop plates for 3 minutes at 18.0° C in Eastman D-19. Following brief immersion of the plates in an acetic acid short stop, fix them for 10 minutes in acid hypo. Wash the

plates in a stream of water for 10 minutes, rinse in distilled water, and finally dry them in a stream of warm air.

- (j) Photometer the Ga: 4033 Å and Mo: 4232 Å lines in all sample and standard spectra. Convert the line and background transmissions into relative intensities by reference to an H & D curve (one plate from each box should be calibrated). Subtract the background relative intensities from the line plus background intensities to obtain the net line intensities. Compute the log ratios of the analysis and internal standard line intensities (Ga/Mo). Plot the log intensity ratios for the standard plates against the log of the gallium quantity. (This should yield a straight line of unit slope.) Refer the log intensity ratios for samples to this working curve to obtain the quantity of gallium obtained in the extractions. Use the intensity ratios of the standards which were photographed on the same plates as the samples to check the validity of the working curve, correcting the latter as may be necessary for any given plate. Finally, calculate the quantity of gallium present in the original samples.

(5) References

LAMS-261
LAMS-266

LAMS-276
LAMS-288

8.4 COLORIMETRIC PROCEDURES8.4-1 Colorimetric Determination of Phosphorus in Uranium and Plutonium Metals

(1) Abstract

The phosphorus is converted to ortho-phosphate by dissolving the sample in an oxidizing acid. The phosphate is then treated with ammonium molybdate and the resulting phosphomolybdic acid complex is extracted into n-butyl alcohol. The alcoholic phase is shaken with stannous chloride solution to give molybdenum blue which is measured spectrophotometrically. Silicate interference is eliminated by extracting the phosphomolybdic acid complex from 1 N H_2SO_4 solution.

(2) Applicability

The method is applicable to both uranium and plutonium metals and to their compounds.

(3) Size of Sample, Limit of Sensitivity and Range

Sample size, 10 - 100 mg. Limit of sensitivity, about 0.2% P, (20 ppm on 10 milligram sample). Range, 0.2 - 12% P.

(4) Reagents

- (a) Conc. HCl (P and As free).
- (b) Conc. HNO_3 (P and As free).
- (c) 10 N H_2SO_4 (approx.) prepared by diluting As free H_2SO_4 .
- (d) 1 N H_2SO_4 prepared by diluting the 10 N H_2SO_4 .
- (e) Stock solution of $SnCl_2$, made by dissolving 10 g of c.p. salt in 25 milliliters of conc. HCl. This solution should be stored in a brown bottle and kept in the dark; it should be made up fresh every 10 days.

- (f) Dilute SnCl_2 prepared by diluting 1 milliliter of the stock solution to 200 milliliters with 1 N H_2SO_4 . This solution should be made up fresh daily.
- (g) Ammonium molybdate solution (5 per cent prepared from Baker's special reagent for micro analysis, P content not over 0.0002 per cent FO_4). This solution should be stored in a paraffin-coated, glass-stoppered bottle to prevent picking up of silica.
- (h) n-Butyl alcohol, redistilled.
- (i) 95 per cent ethyl alcohol, undenatured.
- (j) Stock standard phosphate solution, 100 γ P per milliliter prepared by dissolving 0.4389 g KH_2PO_4 in 1 l. of distilled H_2O .
- (5) Apparatus
- (a) 8 milliliter quartz crucibles.
- (b) Special separatory funnels 30-60 milliliters. Figure 24 .
- (c) 5 milliliter mixing cylinders.
- (d) Spectrophotometer (Beckman).

(6) Procedure

If Plutonium Metal and Its Compounds Are To Be Analyzed,
Heed Health Safety Rules Outlined in Section 8.2.

- (a) To the sample of metal (10 - 100 milligrams) in a 8 milliliter quartz crucible add 0.5 milliliter of concentrated HNO_3 and cover to prevent loss of spray. In case of plutonium metal concentrated HCl is added dropwise after the addition of HNO_3 until solution of the metal begins. When

the reaction subsides more HCl may be added. (9)

(9)

Plutonium metal is difficultly soluble in aqua regia and tends to become passive. The addition of HCl will cause the reaction to begin again. After solution, however, a small amount of black oxide residue remains. In phosphorous analysis this residue is ignored because it is doubtful if it contains an appreciable amount of phosphorous after the H_2SO_4 treatment which follows. If desired, the black residue may be dissolved by heating to fuming with H_2SO_4 .

- (b) After the metal has dissolved take the solution to dryness under an infra-red lamp.
- (c) Take up the residue (with heating) in 0.5 millimeters of 10 N H_2SO_4 .
- (d) Transfer the solution to the specially designed separatory funnel using three 1 milliliter portions of distilled water.
- (e) Add 1.5 milliliters of 5 per cent ammonium molybdate and mix. Let stand for 5 - 10 minutes.
- (f) Add 5 milliliters of n-butyl alcohol and agitate for 2 minutes by passing a current of nitrogen through the side arm of the separatory funnel. The nitrogen should be passed through a scrubbing bottle containing a small amount of 1 N H_2SO_4 and a layer of n-butyl alcohol. The gas issuing from the funnel is passed through a cotton plug or another wash bottle to trap any spray (Figure 24.)
- (g) Let stand 5 minutes to permit the two phases to separate; draw off the aqueous phase and save the metal recovery.
- (h) Wash the n-butyl alcohol layer twice with 4 milliliter

Figure 24
Apparatus for Phosphate Extraction

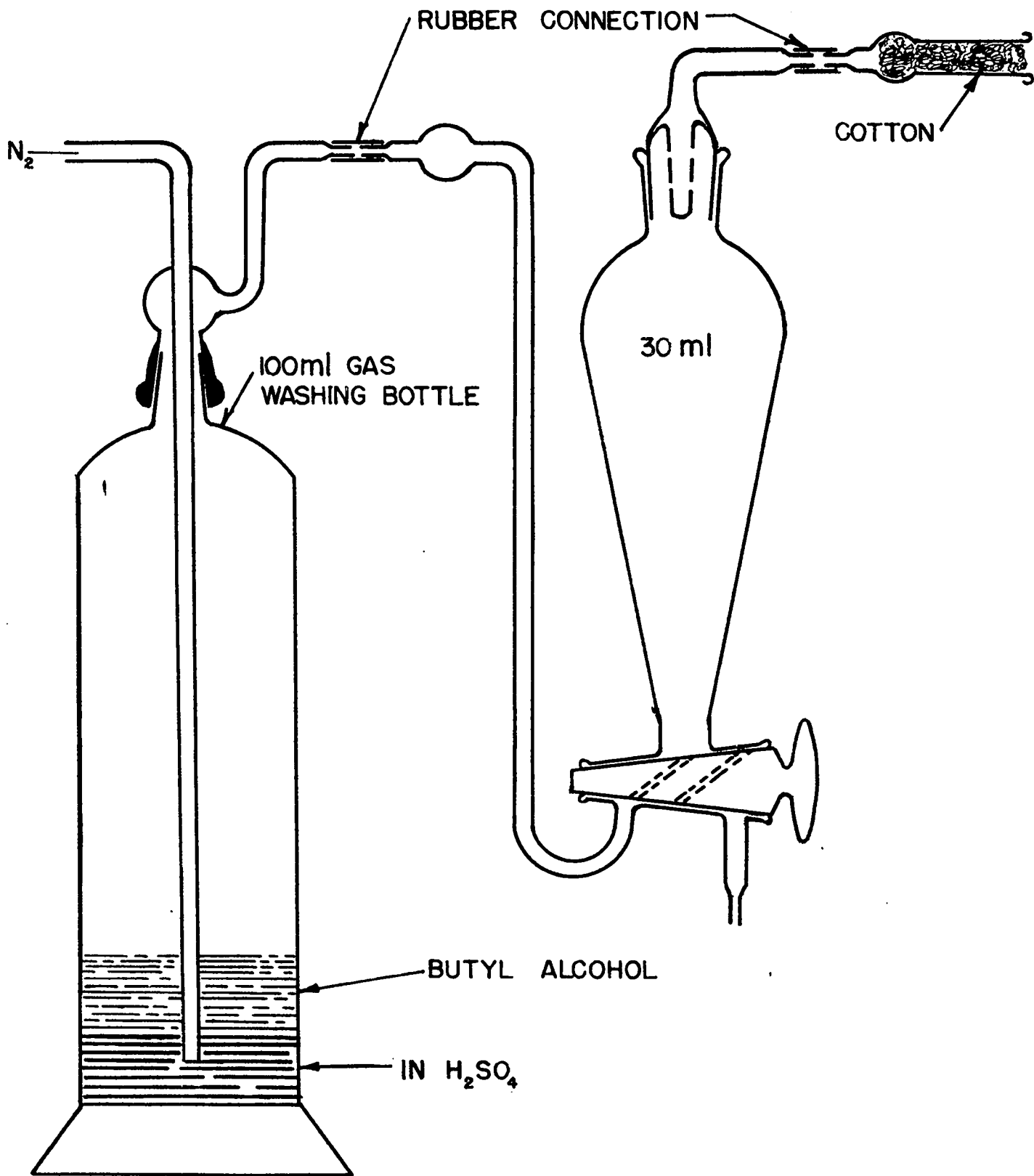

portions of 1 N H_2SO_4 . The washing is carried out by passing nitrogen through the separatory funnel for about 30 seconds.

- (i) Draw off the wash liquid each time and add to the original aqueous phase for recovery of metal.
 - (j) Add 5 milliliters of dilute SnCl_2 solution and agitate by passing nitrogen through the solution for about 1 minute.
 - (k) Draw off and discard the aqueous phase. Transfer the n-butyl alcohol containing the molybdenum to a 5 milliliter glass-stoppered mixing cylinder, washing the funnel with about 1 milliliter 95 per cent ethyl alcohol.
 - (l) Dilute the alcoholic solution to exactly 5 milliliters with 95 per cent ethyl alcohol.
 - (m) Using 0.5 milliliters 10 N H_2SO_4 prepare a reagent blank by exactly the same procedure used in the analysis of a sample (steps (d) through (l) above).
 - (n) Compare the sample with the reagent blank using the Beckman spectrophotometer and wavelength setting of 730 μ .
 - (o) Read the amount of phosphorus contained in the sample from a standard transmittance curve prepared by measuring the transmittance of known amounts of P as KH_2PO_4 or calculate it from the extinction equation given under "Calculations and expression of results".
- (7) Precautions.
- (a) Frequent checks should be made on the reagents to insure a good blank. A good blank of all reagents should give an optical density no greater than 0.20 when compared with pure n-butyl alcohol.
 - (b) It is essential that HNO_3 be added first in the dissolving

- of the metal to prevent possible loss of P as PH_3 ,
- (c) Because of the great tendency for ammonium molybdate solutions to pick up silica, it is essential that this solution be kept in a paraffin coated bottle. This is the most probable source of a high blank.
 - (d) To prevent silica interference it is important that the solution to be extracted be made at least 1 N with H_2SO_4 before adding the ammonium molybdate. Because of the suppressed ionization of silicic acid in 1 N H_2SO_4 the n-butyl alcohol soluble silicomolybdic acid complex is not formed; once formed, however, it is extractable even from 1 N H_2SO_4 ,
 - (e) If the SnCl_2 solution is old a turbidity can be centrifuged down before transferring to the spectrophotometer cuvetts.
 - (f) Arsenic interference is not completely eliminated by extracting from 1 N H_2SO_4 .
- (8) Calculations and Expression of Results

The phosphorus content of the sample may be calculated from the extinction equation

$$c = \frac{E}{0.112}$$

where c represents the micrograms of P per 5 milliliter of n-butyl alcohol and E is the extinction (optical density) observed when the length of the light path is 1 centimeter.

Results are expressed in ppm.

$$\text{ppm P} = \frac{\gamma \text{ P in sample}}{\text{wt. sample in grams}}$$

(9) References

Berenblum and Chain, Biochem. J., 32, 295 (1938)

Project report CK-1229

Project report CK-1326

8.4-2 Colorimetric Determination of Microgram Quantities of Acid-Soluble Sulfide Sulfur

(1) Abstract

Sulfide sulfur in the sample is converted to H_2S by treatment with HCl and is distilled into a solution of $ZnAc_2$. The distillate is treated with p-amino-dimethylaniline and $FeCl_3$ which converts the H_2S to methylene blue. The latter is then determined spectrophotometrically.

(2) Applicability

The method has been applied to uranium and to plutonium metals and is presumably applicable to any materials which dissolve in non-oxidizing acids with the release of their sulfide sulfur as H_2S .

(3) Size of Sample and Limit of Sensitivity

The size of sample is determined by the sensitivity required. Since the limit of detection of the method is approximately 1μ , the limits of sensitivity are:

<u>Sample Size</u>	<u>Limit of Sensitivity</u>
10 mg.	100 ppm
100 mg.	10 ppm
1 gram	1 ppm

(4) Reagents

(a) Separation of H_2S

1. 2 N HCl for dissolving sample.
2. 2 per cent $ZnAc_2$ solution for trapping H_2S .

(b) Color Development

1. Standard Na_2S solution for determining specific extinction -- Dissolve 0.746 grams $Na_2S \cdot 9H_2O$ in H_2O and dilute to 100 milliliters. 1 milliliter \approx 1 milligram. S^{2-} . (If care is taken to select large, well-formed crystals of $Na_2S \cdot 9H_2O$ which are not discolored and are not wet, this solution may be taken as a primary standard and need not be assayed. (10)

(10)

A few assays have indicated that such a solution is not more than 1 per cent below the calculated value.

2. Caro-Fischer reagent -- Dissolve 25 milligrams p-aminodimethylaniline (Eastman practical grade) in 7 milliliters concentrated HCl. Add 2.0 milliliters 0.1 M $FeCl_3$ solution and dilute to 20 milliliters. This solution must be prepared fresh daily and is hence best made up in small quantities.

(5) Apparatus

(a) Separation of H_2S

Same as for volumetric method. See Section 8.6-1.

(b) Determination

1. 25 milliliter volumetric flasks.
2. 2 and 4 milliliter pipets

3. Assorted micropipets -- 5, 10, 20, 25 λ .
4. Constant temperature water bath.
5. Spectrophotometer (e.g. Coleman Model No. 11).

(6) Procedure

If Plutonium and Its Compounds Are To Be Analyzed Heed
Health Safety Rules Outlined In Section 8.2

(a) Separation of H_2S

Same as for volumetric S method. See Section 8.6-1.

Use 4 milliliter 2 per cent $ZnAc_2$ solution to trap the H_2S .

(b) Determination of H_2S

1. Transfer the $ZnAc_2$ solution to a 25 milliliter volumetric flask and dilute to about 20 milliliters with distilled water. Place the flask in the constant temperature bath at $25^\circ C (\pm 0.5^\circ C)$ and allow it to reach thermal equilibrium.
2. Add 2.0 milliliters freshly prepared Caro-Fischer solution and mix well. Return the flask to the bath for about 5 minutes.
3. Dilute to volume with distilled water and allow to remain in the constant temperature bath for 20 -- 30 minutes more.
4. Determine the extinction spectrophotometrically at 660 $m\mu$ using as the reference a similarly prepared solution containing 4 milliliter 2 per cent $ZnAc_2$ and 2.0 milliliter Caro-Fischer solution diluted to 25 milliliters. The reference should be prepared fresh daily, preferably at the same time as the samples.

(7) Blank procedure

It is unnecessary to run blanks on the distillation. The reference solution is equivalent to a blank on other reagents.

(8) Precautions

(a) Separation

Same as for volumetric procedure, Section 8.6-1.

(b) Determination

Since the Lauth reaction (conversion of H_2S to methylene blue) is not quantitative, all conditions must be carefully controlled so that the yield may be reproducible:

1. Temperature control is very important and the reaction must always be carried out at the same temperature at which the specific extinction was determined. Not more than 0.5°C variation should be permitted.
2. The Caro-Fischer solution must be freshly prepared.
3. The extinction of the solution slowly increases on standing, especially if large amounts of S^{2-} are present. The increase after 20 minutes, however, is very slight, usually less than 1 per cent from 20 minutes to 2 hours.
4. A more dilute Na_2S standard solution should not be used since it would not be stable. The 1 milligram per milliliter solution should show no significant changes over a period of several weeks if it is kept well stoppered.
5. A single determination of the specific extinction should be sufficient so long as all conditions are kept unchanged. It is desirable occasionally,

however, to check the value by running a standard.

(9) Calculation and Expression of Results

From the series of standards prepared from the standard Na_2S solution (omitting the distillation) calculate the "extinction factor", f , ⁽¹¹⁾ which is defined as the quantity of S^{--} in micrograms required to produce unit change in extinction for standardized procedure. f can best be evaluated by the least squares equation:

$$f = \frac{\sum x^2 - \frac{(\sum x)^2}{n}}{\sum xy - \frac{\sum x \sum y}{n}}$$

where

x = micrograms of S^{--} in the standardized volume of 25 milliliters

$y = E =$ extinction

$n =$ number of observations

The summation is taken over the entire series of standards run. 5, 10, 15, 20, and 25 γ S is a convenient series, since it is easily obtainable with the standard Na_2S solution and commercial micro-pipets. The precision of the colorimetric determination may be evaluated from the five standards by calculating an f for each concentration and comparing it with the least-squares f . This is best expressed as the standard deviation, σ .

⁽¹¹⁾ See "Spectrophotometric Units", Section III A, LA-416.

$$\sigma = \sqrt{\frac{\sum (\Delta f)^2}{n-1}}$$

where Δf is the difference between an individual f and the least-squares f , $n =$ the number of standards.

$\frac{\sigma}{f} \times 100 =$ the standard deviation expressed as per cent error. In addition "spiked" samples should be distilled to check on the recovery obtained.

The Amount of $S^{\bar{}}$ present in the sample is simply

$$S^{\bar{}} = E \cdot f$$

when the above method of calculation is used.

(10) References

L.H. Almy, J. Am. Chem. Soc. 47, 1381 (1925).

A. Suslova, Lab. Prakt. (U.S.S.R.) 16, No. 6, 19-20 (1941)

(in Chemical Abstracts 36, 5110).

O. Spengler, K. Zablinsky and A. Wolf, Z. Wirtschaftsgruppe

Zuckerind. 90, 106 (1940) (in Chemical Abstracts

35, 4988).

R. Pomeroy, J. Am. Water Works Assoc. 33, 943 (1941)

R. Pomeroy, Water Works and Sewerage, 83, 279 (1936)

I. St. Lorant, Z. Physiol. Chem. 185, 245 (1929)

W. Mecklenberg and F. Rosenkranzer, Z. Anorg. Chem. 86, 143 (1914)

Project Reports

CC-2078

CK-928

CK-993

CK-1229

CK-1714

8.4-3 Colorimetric Determination of Iron in Plutonium Materials

(1) Abstract

The iron is reduced to the ferrous state with hydroxylamine and determined spectrophotometrically in the presence of trivalent plutonium as the ferrous-orthophenanthroline complex.

(2) Applicability

The method permits the determination of iron down to 100 ppm in relatively pure plutonium metal, plutonium-gallium alloys and plutonium nitrate process solutions.

(3) Method of Sampling

Samples received as solutions are aliquoted by weight or by volume. When samples are in the form of small metal buttons, the entire button is dissolved in constant-boiling HCl and a suitable aliquot of the solution is taken.

(4) Range and Limit of Sensitivity

Although the optimum amount of iron per determination lies between 10 and 40 micrograms, amounts from 1 to 100 micrograms can be determined with some sacrifice in accuracy. The aliquot size should be governed by these limits.

(5) Reagents

- (a) Constant-boiling HCl, Fe free.
- (b) HCl, 1 N.
- (c) Acetic acid-sodium acetate buffer solution. This is prepared by dissolving 84 grams of reagent grade sodium acetate trihydrate in distilled water, adding 20 milli-

liters of glacial acetic acid and diluting to one liter.

- (d) 20 percent hydroxylamine hydrochloride solution. This is prepared by dissolving Eastman's white label reagent in distilled water.
- (e) 0.5 per cent o-phenanthroline. The reagent is prepared by dissolving recrystallized O-phenanthroline in distilled water. A small amount of 95 per cent ethyl alcohol may be used to facilitate solution. This reagent should be colorless.
- (f) Dilute ammonium hydroxide, Fe free. (100 milliliters of concentrated reagent diluted to 1 liter.)

(6) Apparatus

- (a) Volumetric pipets, 10 - 200 λ capacity, and 1 milliliter capacity.
- (b) Weight pipets, 200 λ capacity. See Figure 33.
- (c) Syringe pipet controls.
- (d) Volumetric flasks, 10 milliliters.
- (e) Spectrophotometer. (Beckman)
- (f) Cuvets, 1 centimeter light path.

(7) Procedure

Head Health Safety Rules Outlined in Section 8.2

- (a) Transfer the aliquot to the bottom of a dry 10 milliliter volumetric flask, being careful to get none of the solution in the neck of the flask. For samples containing less than 300 ppm of iron, take two aliquots for plutonium blanks and two aliquots for determinations. For samples containing more than 300 ppm of iron one plutonium blank is sufficient.

One plutonium blank is sufficient in any case if a fixed absolute accuracy throughout the range is all that is required.

- (b) Add 200 λ of hydroxylamine hydrochloride solution and allow to stand one hour or longer.
- (c) Add 1 milliliter of acetic acid-sodium acetate buffer and mix thoroughly.
- (d) Add 1 milliliter of dilute ammonium hydroxide and again mix thoroughly.
- (e) Add 200 λ of 0.5 per cent o-phenanthroline to the samples in which iron is to be determined (not to the plutonium blanks), mix thoroughly, and allow to stand for 30 minutes. Dilute with distilled water to 10.0 milliliters and mix thoroughly.
- (f) Let the solution stand for 30 minutes and then transfer about 3 milliliters of the solution to a clean, dry Beckman cuvet.
- (g) If equal volume aliquots were taken, use the plutonium blank as a reference. If unequal weight aliquots were taken, use distilled water as a reference (see Precaution C). Read the extinction at 515 millimicrons. For unequal weight aliquots correct the observed extinction of the sample for the extinction caused by plutonium. Calculate this from the plutonium blank.
- (h) Determine the extinction factor by carrying known amounts of iron through the procedure. Distilled water is used as

a reference in reading the extinction (see Precaution c). The concentration of HNO_3 should be approximately the same in the extinction factor determination as in the sample determinations (see Precaution d). The extinction factor is expressed as micrograms of iron per extinction unit. This factor was determined by one operator as 49.9 γ iron per extinction unit in the absence of HNO_3 ; 51.0 γ iron per extinction unit in the presence of 0.005 M HNO_3 . The extinction factor for Pu at 515 millimicrons was found to be approximately 150 milligrams Pu per extinction unit.

(8) Precautions

- (a) Dilution of the sample while still in the +4 valence may cause hydrolysis. The resulting oxide will go into solution slowly when hydroxylamine hydrochloride is added.
- (b) SO_4^{2-} appreciably decreases the rate of reduction of plutonium to +3 valence. It is presumed to have little effect on the quantitative reduction of the iron. Samples containing sulfate are usually allowed to reduce for 12 to 24 hours.
- (c) It is convenient to use distilled water or the plutonium blank as a reference. The use of either is valid only if the iron content of the reagents is negligible and if the extinction of the O-phenanthroline reagent itself is negligible. If the extinction of a reagent blank exceeds 0.010 it should be subtracted from the observed extinction or the

reagent blank should be used as the reference. Each operator should run a reagent blank on any particular set of reagents used.

- (d) HNO_3 present in amounts to give a final concentration of 0.005 M in the 10 milliliter volume appears to decrease the extinction by about 2 per cent. In 0.5 M HNO_3 , the decrease is of the order of 90 per cent. If the HNO_3 concentration should exceed 0.01 M (in the final 10 milliliter volume) it is removed between steps b and c by adding a small excess of H_2SO_4 to the aliquot and taking it to dryness in a platinum crucible under an infra-red lamp (see Figure 34).

(9) Calculations

Express the result as micrograms of iron per gram of plutonium. Micrograms of iron = extinction x extinction factor.

(10) References

LAMS-122

LAMS-127

8.4-4 Colorimetric Determination of Sub-Microgram quantities of Boron in Calcium Metal

(1) Abstract

Calcium metal is oxidized with water and the hydroxide is dissolved in a slight excess of nitric acid. The boron, in the presence of sodium nitrate, is distilled as methyl borate from a specially designed quartz still. The distillate is trapped in calcium hydroxide solution and the boron is estimated by the colorimetric curcumin procedure.

(2) Applicability

The method has been applied to relatively pure calcium metal and calcium oxide. It should be equally useful for other metals and similar compounds. Since both calcium borate and calcium boride are soluble in nitric acid, it is assumed the method can be used to determine boron if present, in either of these forms.

(3) Range and Limits of Sensitivity

The procedure here described permits the determination of boron in the range 0.05 to 0.5 micrograms which corresponds to a concentration of 0.5 to 5 ppm in a 100 milligram sample, with an accuracy of about 12 per cent.

(4) Sampling

Small chips are removed from the calcium metal piece and ground in a Wiley mill to fineness -20 mesh to +80 mesh. A 100 milligram sample is taken for analysis.

(5) Reagents

Store All Reagents (Except Where Noted) in Quartz Containers

- (a) Distilled water, from a double Barnstead still. If free boric acid is present in the water supply, it will be necessary to distill from NaOH through a quartz still.
- (b) Nitric acid, concentrated, c.p. The boron content should be less than 0.1 microgram per milliliter. Distillation from quartz may be necessary.
- (c) Calcium hydroxide, 0.1 N suspension, prepared from boron-free calcium metal and distilled water.

(12)

Boron-free calcium metal was obtained from the Electrometallurgical Corporation, Niagara Falls. It was specially prepared by electrolyzing calcium from a boron-free molten calcium chloride salt. The metal in vacuo in an iron retort.

- (d) Sodium nitrate, reagent grade crystals.
- (e) Methyl alcohol, absolute. Distill from sodium hydroxide in a quartz still equipped with an efficient spray trap. The alcohol should contain not more than 0.0005 micrograms of boron per milliliter.
- (f) Hydrochloric acid 6N. Dilute c.p. concentrated acid with an equal volume of distilled water.
- (g) Curcumin, 0.1 per cent in ethyl alcohol, using c.p. material like Eastman's best grade.
- (h) Ethyl alcohol, 95 per cent. Distill from NaOH through a quartz still.
- (i) Oxalic acid, 15 per cent solution in distilled water. Use c.p. crystals.
- (j) Standard boric acid solution, 1 milliliter containing 1 microgram of boron. To make stock solution, dissolve 35.7 milligrams c.p. H_3BO_3 crystals and dilute to 250 milliliters with distilled water. 10 milliliters of this stock solution diluted to 250 milliliters contains 1 microgram of boron per milliliter.
- (k) Sodium hydroxide, 3 N. Sodium from a solution of c.p. sodium chloride in distilled water is electrolyzed into a mercury cathode forming sodium amalgam. The sodium amalgam is drawn off into a quartz beaker, distilled water added and allowed to stand overnight. 10 ampere hour of current will yield sufficient sodium for approximately 100 milli-

liters 3 N solution. The NaOH solution is decanted into a weighed platinum bottle. The normality is determined by titrating portions with a standard acid. The weight of the remaining NaOH solution is determined by weighing the bottle and contents, then subtracting the weight of the bottle. The volume of the NaOH solution is determined by this weight and from standard density tables. Dilution to a concentration of 3 N is made by adding the calculated volume of distilled water. For a check, a final titration is made with standard acid. The NaOH solution is stored in the platinum bottle. This method of preparation produces sodium hydroxide with extremely low boron content.

(6) Apparatus

- (a) Four quartz stills (Figure 25).
- (b) Spectrophotometer, (Beckman), using absorption cells of 1.00 centimeter light path.
- (c) Steam bath, with openings for four or more vessels, equipped with quartz manifold and distributing apparatus for evaporating in an atmosphere free from carbon dioxide (Figure 26).
- (d) Drying oven, 10 x 12 x 12 inches, electrically heated and thermostatically controlled. Insert a glass tube through a vent in the top, terminating the tube near the floor of the oven. The air stream is filtered through cotton and dispersed by blowing through the tube into a 10 centimeter evaporating dish placed on the floor of the oven.

Figure 25

Quartz Still for Boron Determination

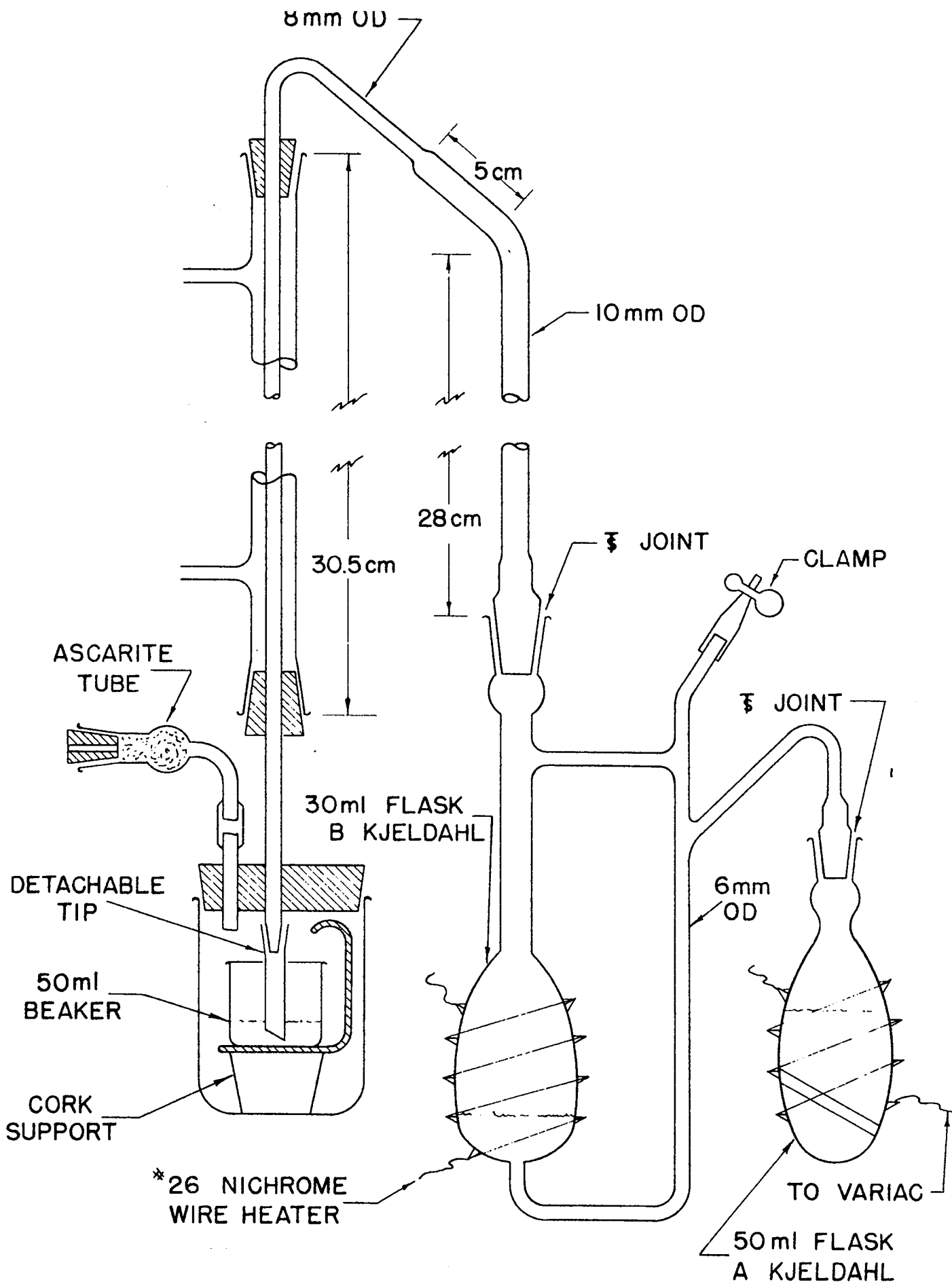
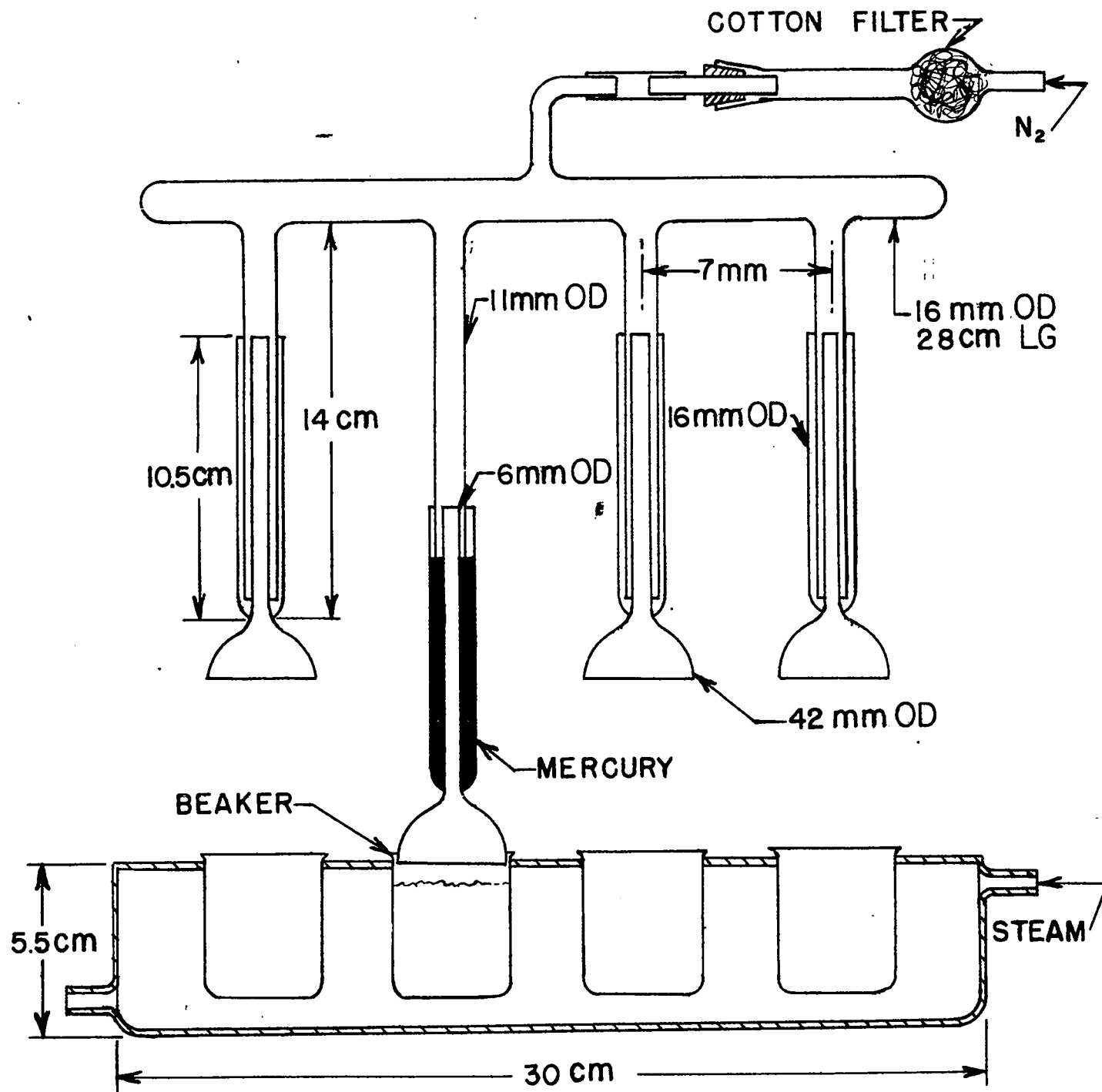

Figure 26

Steam Bath with Quartz Manifold



- (e) Two flasks, volumetric, 250 milliliters, quartz, g.s.
- (f) Four flasks, volumetric, 10 milliliter, pyrex, g.s.
- (g) Four flasks, Erlenmeyer, 250 milliliters, quartz.
- (h) Two pipets, 5 milliliters, graduated in 0.1 milliliter.
- (i) Five pipets, 1 milliliter, graduated in 0.01 milliliter
- (j) Filter dome equipped with medium porosity sintered glass filter.
- (k) Soft glass dropping bottle, 60 milliliters.
- (l) Four platinum evaporating dishes, 40 milliliters (Quartz beakers may be substituted).
- (m) Four beakers, quartz, 50 milliliters.

(7) Procedure

(a) Preparation of standard curve.

(It is recommended that quadruplicate determinations be made for each point on the standard curve.) Add 2.5 milliliters 0.1 N $\text{Ca}(\text{OH})_2$ suspension to each of several 40 milliliters platinum dishes. ⁽¹³⁾ Add 0, 0.1, 0.2, 0.3, 0.4, etc.,

(13)

50 milliliter quartz beakers may be substituted although platinum dishes are easier to handle, especially in dissolving the precipitate with HCl.

up to 0.8 microgram of boron (0.8 milliliter standard boric acid solution) to successive dishes. Place on the steam bath, lower the quartz funnel in place (Figure 26,) adjust the flow of nitrogen so that it ripples the surface of the liquid, and evaporate to dryness. Watch carefully and remove immediately after dryness is reached and allow to cool. To each dish add 0.25 milliliters 6 N HCl and carefully dissolve all precipitate. Next add 0.5 milliliters 0.1 per cent alcoholic curcumin and then 0.5 milliliter 15 per cent oxalic

acid. Swirl to mix thoroughly. Place in the drying oven with forced ventilation, at a temperature of 55°C $\pm 3^{\circ}$ and observe the time of drying. Leave in oven 30 minutes in excess of drying time. Remove and allow to cool. Extract the contents of each dish with 1 milliliter 95 per cent ethyl alcohol. Filter through a medium sintered glass filter catching the clear filtrate in a 3 milliliter volumetric flask. Repeat with successive small portions of alcohol until all color is quantitatively removed. Dilute with additional alcohol to a final volume of 3 milliliters, shake, transfer to a cuvet and stopper. Read the extinction E at 540 millimicrons in the spectrophotometer using 95 per cent ethyl alcohol as reference. Plot extinction against micrograms of boron present. Repeat in quadruplicate for each level of boron. Figure 27 shows a typical standard curve.

(b) Analysis of sample.

Pipet 2.5 milliliters of a 0.1 N $\text{Ca}(\text{OH})_2$ suspension into a clean 50 milliliter quartz beaker. Set the quartz condenser tip in place. Place the beaker in the CO_2 trap and adjust so the condenser tip is beneath the surface of the base.

Weigh 0.1 gram of calcium metal into flask B, keeping the flask in a horizontal position. Add 0.5 milliliter distilled water, keeping the flask under the tap until action ceases. Add 200 milligrams NaNO_3 crystals and then carefully acidify the solution by adding 0.4 milliliter concentrated HNO_3 , keeping the flask cool under the tap. Swirl gently

Figure 27

Standard Curve for Boron Analysis

Reference Solution: Ethanol (in regard to vertical scale)

$$\text{Extinction factor} = \frac{\frac{\% \text{ Boron}}{3 \text{ ml}}}{E - E_{\text{Blank}}} = 0.436$$

Standard deviation (σ) = 3%

$$\lambda = 540 \text{ m}\mu$$

Light path = 1.00 cm

Beckman quartz spectrophotometer

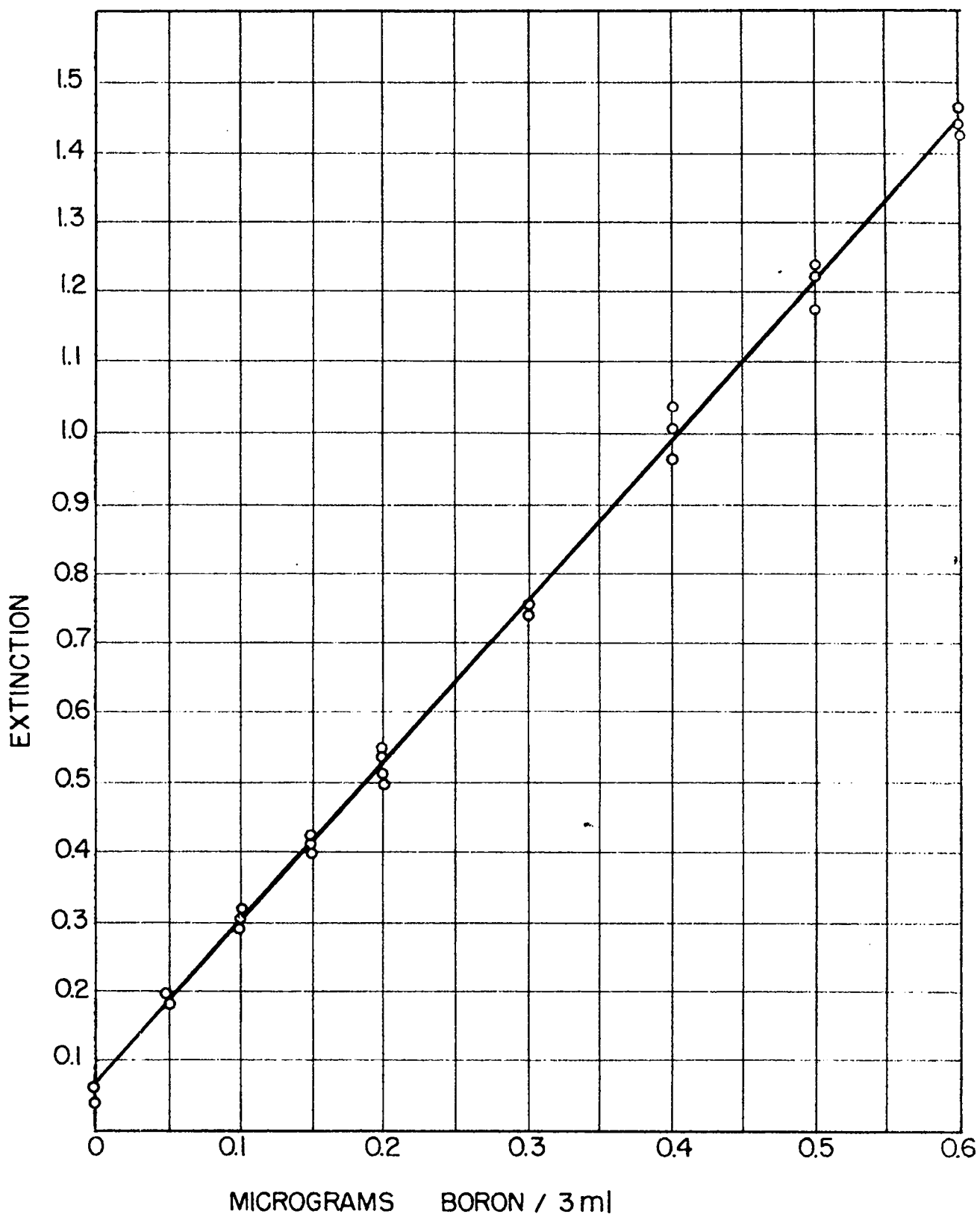

to dissolve all calcium hydroxide. (Keep the flask horizontal during the above operations.) This amount of HNO_3 is sufficient for an excess of 0.1 milliliters.⁽¹⁴⁾ Next add 8 milliliters purified methyl alcohol and immediately connect flask B to the condenser.

(14)

This condition of acidity is important because too much HNO_3 seems to interfere in the subsequent distillation of methyl borate.

Pour 50 milliliters of purified methyl alcohol into flask A and connect to still. Place pinch clamp in position. Heat flask A, gently at first, to prevent bumping. Increase heat gradually until alcohol vapors continuously pass through flask B. Then turn on Flask B heater and adjust the Variac to maintain the initial volume in the flask during the entire distillation. Distill approximately 45 milliliters methyl alcohol into the receiver, and then lower the receiver until the condenser tip is above the surface of the distillate. Continue distilling until one or two milliliters of methyl alcohol have washed the condenser tip. Remove the pinch clamp and turn off both heaters.

Place the receiver on the steam bath and lower the quartz funnel into place. Regulate the flow of nitrogen so that it ripples the surface of the liquid in the beaker, and evaporate to dryness. Remove immediately upon reaching dryness, allow to cool and proceed with the color development as described in (a) above.

110

It will be noted that evaporation on the steam bath has left a thin film of precipitate on the walls of the beakers. It is essential that all this precipitate be dissolved by the 0.25 milliliter 6 N HCl. This is best accomplished by tilting the beakers and rotating slowly. Care and patience will be essential in developing this technique. It is equally important that the same procedure be followed after the addition of the oxalic acid.

(8) Procedure for Total Reagent Blank

Pipet 1.5 milliliters 3 N electrolytic NaOH into flask B. Add 200 milligrams NaNO_3 crystals, 0.4 milliliter concentrated HNO_3 and 8 milliliters purified methyl alcohol. Proceed with distillation and color development as described above. (Since the electrolytic NaOH is boron free, this procedure results in a true reagent blank.) (15) Determine the reagent blank at frequent intervals to guard against contamination.

(9) Procedure for Individual Reagent Blanks

If the total reagent blank is greater than 0.10 extinction units when using the Beckman spectrophotometer and regular cuvetts, further purification is necessary. To determine that part of the total blank contributed by the various reagents proceed as follows:

(15)

If boron-free calcium metal is at hand, an alternate procedure is as follows: Weigh 0.1000 gram calcium metal into the distillation flask. Dissolve and proceed as described under "Analysis of Sample".

Ca(OH)₂, HCl, Curcumin, Oxalic acid: Measure 2.5 milliliters of the 0.1 N Ca(OH)₂ suspension into each of 4 platinum evaporating dishes. Evaporate to dryness on the steam bath in an atmosphere of nitrogen. Allow to cool and proceed with the color development as described under "Preparation of Standard Curve". In other words, carry out the standard curve procedure omitting the addition of boron.

Methyl Alcohol: Measure 2.5 milliliters of the 0.1 N Ca(OH)₂ suspension into each of four platinum evaporating dishes. Add 55 milliliters methyl alcohol from a pipet to each dish and proceed as above. The value for the extinction obtained here minus the value for the optical density obtained above gives the data for the calculation of the boron content of the methyl alcohol.

Nitric Acid: Pipet 0.10 milliliters concentrated nitric acid into each distillation flask, add 8-10 milliliters purified methanol and immediately connect to the condenser. Add approximately 50 milliliters purified methanol to Flask A (figure 25) and distill, evaporate and develop color as described under "Analysis of Sample". The extinction obtained in this procedure minus the total extinction obtained under "Methyl Alcohol" gives the data for calculating the boron content of the nitric acid.

Sodium Hydroxide: If it is suspected that the sodium hydroxide is not free from boron, proceed as follows: Carry out the procedure for the "Total Reagent Blank", omitting the sodium nitrate. The value for the extinction obtained here minus the total extinction obtained under nitric acid gives the data for calculating the boron content of the sodium hydroxide. Correction for 0.4 milliliter nitric acid must be applied since this is a larger volume of acid

than was used under "Nitric Acid".

Sodium Nitrate: The "total reagent blank" minus the blank obtained under "nitric acid" gives the data for the calculation of the boron content of the sodium nitrate. Experience has shown the boron content of reagent quality sodium nitrate to be negligible.

(10) Precautions

- (a) Observe every possible precaution to prevent reagent contamination.
- (b) Store all reagents, except where noted, in quartz containers. Corning 728 glass is satisfactory for methyl and ethyl alcohols. The electrolytic NaOH must be kept in a platinum bottle.
- (c) When a new quartz still is to be put in operation, distill through it a considerable quantity of methyl alcohol to remove boron from the surface of the quartz. Experience has shown that a new quartz surface is contaminated with boron which is difficult to remove. It actually requires weeks to decontaminate a new still. Exercise great care in the use of decontaminated stills.
- (d) Keep all pipets, glassware and still scrupulously clean. Always rinse with distilled water.
- (e) Do not use pyrex pipets. Quartz pipets are to be preferred although Kimball glass seems to be satisfactory.
- (f) Maintain drying oven temperatures at $55^{\circ}\text{C} \pm 3^{\circ}$.
- (g) Keep flask B cool during addition of reagents to prevent loss of boron.
- (h) Keep the volume of solution in flask B at the initial volume during the entire distillation.

- (i) Exclude CO_2 from receiver during distillation. This is the purpose of the enclosure placed around the receiving vessel (Figure 25).
 - (j) To prevent bumping, do not heat flask A too rapidly
 - (k) Avoid spattering during evaporation on the steam bath.
 - (l) Exclude other work, especially glass blowing, from the laboratory as much as possible.
- (11) Calculations and Expression of Results

Express results in parts per million unless otherwise requested.

Calculations by a method of least squares gives a slope of 2.29 for the standard curve (Figure 27). This number indicates the increase in extinction caused by one microgram of boron under the conditions of the experiment.⁽¹⁷⁾ For ease in calculating results, the reciprocal of the slope which is given the name "extinction factor", is used. In this case the "extinction factor" is $\frac{1}{2.29}$ or 0.436. The significance, then, of the "extinction factor" is that it represents the amount of boron (in micrograms of B per 3 milliliters) required to produce a change of one unit in the extinction.

(17)

This value for the slope of the standard curve holds for the type of spectrophotometer and cuvetts used. In addition, the conditions existing for the color reaction with curcumin also influence the slope. The value given above should not be taken as real unless actually determined by experiment.

To calculate the amount of boron in micrograms, multiply the increase in extinction by the extinction factor.

E (increase) = E sample - E reagent blank

Amt. boron (in micrograms) = $(E$ sample - E reagent blank) x
Extinction factor.

Expressed as parts per million:

$$B \text{ (ppm)} = \frac{(E \text{ sample} - E \text{ reagent blank}) \times \text{Extinction factor}}{\text{Wt. sample in grams}}$$

(12) Reference

Naftel, James A., Ind. Eng. Chem., Anal. Ed., 11, 407 (1939)

Project Report LA-303 (Terminal Report)

8.4-5 Colorimetric Determination of Sub-Microgram Quantities of Boron in Uranium Tetrafluoride

(1) Abstract

Uranium tetrafluoride is dissolved in 3 N sodium hydroxide and 30 per cent hydrogen peroxide. The fluoride ion is either precipitated as CaF_2 or complexed as FeF_6^{4-} . The boron is distilled as methyl borate. The quartz stills described in section 8.4-4. are used for distillation. The methyl borate distillate is trapped in calcium hydroxide solution and the boron estimated by the colorimetric curcumin procedure.

(2) Applicability

This method applies to relatively pure uranium tetrafluoride.

(3) Range and Limits of Sensitivity

In 100 milligram samples, 0.05 to 0.5 micrograms of boron have been determined with an accuracy \pm 10 per cent in the final volume of 3 milliliters to which the solution is diluted for spectrophotometric determination. This corresponds to a concentration range from 0.5 to 5 parts per million.

(4) Sampling

The sample must be finely ground in a boron-free mortar.

Coarse particles will not dissolve in the quantities of reagents employed.

(5) Reagents

The reagents required are listed in Section 8.4.4. In addition to these the following are needed:

- (a) Hydrogen peroxide, 30 per cent. Merck's reagent grade.
- (b) Ferric chloride, Baker's c.p. 10 grams $\text{FeCl}_3 \cdot 6\text{H}_2\text{O}$ are dissolved in 50 milliliters distilled water in a quartz volumetric flask. 25 milliliters concentrated HCl are added and the volume made up to 100 milliliters.
- (c) Calcium nitrate solution. To 10 grams boron-free calcium metal in a quartz flask, add distilled water dropwise until all the metal has been oxidized. Then add the calculated amount of concentrated nitric acid necessary to convert the calcium hydroxide to calcium nitrate. Dilute to 100 milliliters with distilled water.

(6) Apparatus

The apparatus required is described in Section 8.4-4.

(7) Procedure

- (a) Preparation of standard curve.

Prepare a standard curve in the same manner as described in Section 8.4.4.

- (b) Analysis of the sample

Pipet 2.5 milliliters of 0.1 N $\text{Ca}(\text{OH})_2$ suspension into a clean 50 milliliter quartz beaker. Set the quartz condenser tip in place. Place the beaker in the CO_2 trap and adjust so the condenser tip is beneath the surface of the calcium hydroxide but not touching the bottom of

the beaker (Figure 25).

Weigh 0.100 gram of finely ground sample and transfer to the distillation flask. Add 1 milliliter 3 N NaOH and 0.5 milliliter 30 per cent H_2O_2 . Shake to mix thoroughly, warm slightly and allow to dissolve. This usually requires five to ten minutes. After solution is complete, heat to boiling for thirty seconds to decompose most of the excess H_2O_2 and to remove some of the water from the solution. Cool the flask under the tap. From this point two methods for preventing the distillation of fluoride ion are available: Method I. To the cold solution add 0.5 milliliter $Ca(NO_3)_2$ solution, 0.20 milliliter concentrated HNO_3 , then shake to mix. Add 8 - 10 milliliters purified methyl alcohol and quickly connect the flask to the condenser. Pour 50 milliliters purified methyl alcohol into flask A (Figure 25) and distill approximately 45 milliliters methyl alcohol into the receiving beaker while keeping the volume of solution constant in the distilling flask. This is easily accomplished by proper adjustment of the Variacs.

Method II. To the cooled solution add 1 milliliter $FeCl_3-HCl$ solution. Shake to mix thoroughly. (If the $FeCl_3-HCl$ solution is prepared as directed under "Reagents", one milliliter will contain sufficient hydrochloric acid to give the proper acidity). Add 8 - 10 milliliters purified methanol and quickly connect the distillation flask to the condenser. Pour 50 milliliters purified methyl alcohol into flask A,

as in Method I and distill approximately 45 milliliters into the receiving beaker, while keeping the level of the liquid constant in the distilling flask.

From this point the procedure is the same for either method. Before the end of the distillation, lower the receiver until the condenser tip is above the surface of the liquid in the beaker. Continue distilling until one or two milliliters of methyl alcohol have washed the condenser tip. Remove the pinch clamp and turn off both Variacs.

Immediately place the beaker on the steam bath, lower the quartz funnel into place (Figure 26) and turn on a sufficient flow of nitrogen to ripple the surface of the liquid and evaporate it to dryness. Remove from the steam bath immediately upon reaching dryness, allow to cool and proceed with the color development as follows:

Add 0.25 milliliters 6 N HCl to the beaker. Tilt and rotate the beaker until the acid has dissolved all the residue on the walls. This step is important and requires patience and practice to develop sufficient technique to prevent any loss of contents. Then add 0.50 milliliters of 0.1 per cent alcoholic curcumin and then 0.50 milliliter 15 per cent oxalic acid. Again tilt and rotate the beaker to bring the reagents into contact with the wall surface of the beaker. Immediately place the beaker in the drying oven at a temperature of $55^{\circ} \text{C} \pm 3^{\circ}$. Note when dryness is reached and continue to heat at the same temperature for an additional 30 minute period. Remove from the oven and allow to cool. Extract the color from the contents of the beaker with 1

milliliter of 95 per cent ethyl alcohol. Filter through a medium porosity sintered-glass filter into a 3 milliliter volumetric flask. Continue extracting and filtering with small volumes of alcohol until the color has been quantitatively extracted and transferred to the volumetric flask. Dilute to a final volume of 3 milliliters with additional alcohol.

Pour into standard Beckman cuvet having a 1.00 centimeter light path, stopper and determine the extinction at a wavelength of 540 millimicrons using 95 per cent ethanol as a reference solution.

(8) Procedure for the Total Reagent Blank

Since calculation of the amount of boron present involves a knowledge of the boron content of the reagents used, it is necessary that a "total reagent blank" be determined. This is done as follows: For Method I and Method II carry out the procedure for analysis of the sample omitting the weighed sample. The extinction under these conditions should not be over 0.070. If an abnormally high reagent blank is found it is necessary to find the source of contamination and reduce it by purification of the reagent or reagents involved.

(9) Precautions

The precautions given in Section 8.4-4 apply here.

(10) Reference

LA-303 (Terminal Report)

8.4-6 Colorimetric Determination of Sub-Microgram Quantities of Boron in Plutonium Metal

(1) Abstract

Plutonium metal is dissolved in 6 N HCl. The boron is distilled as methyl borate from a specially designed quartz

still. The distillate is trapped in a calcium hydroxide suspension. The boron is estimated by the colorimetric curcumin procedure.

(2) Applicability

The method has been applied to relatively pure plutonium metal and to gallium alloys of the metal containing up to 3.5 atomic per cent gallium.

(3) Range and Limits of Sensitivity

The procedure described here permits the determination of boron in the range 0.05 to 0.5 micrograms, which corresponds to a concentration of 0.5 to 5 ppm in a 100 milligram sample, with an accuracy of ± 10 per cent. 0.03 micrograms of boron can be estimated with an accuracy of ± 20 per cent in the final volume of 3 milliliters to which the solution is diluted for spectrophotometric determination.

(4) Sampling

The metal is cut into pieces ranging from 50 to 100 milligrams in weight. If surface contamination is suspected it is recommended that the sample be cleaned by electrolytic polishing method described in Section 8.2. The metal is then placed in concentrated nitric acid for a few seconds, washed in distilled water and then in acetone and allowed to dry.

(5) Reagents

See Section 8.4-4.

(6) Apparatus

See Section 8.4-4.

(7) Procedure

Heed Health Safety Rules Outlined In Section 8.2

(a) Preparation of a standard curve.

Prepare a standard curve in the same manner as described in Section 8.4-4.

(b) Analysis of the sample.

Pipet 2.5 milliliters of 0.1 N $\text{Ca}(\text{OH})_2$ suspension into a clean 50 milliliter quartz beaker. Set the quartz condenser tip in place. Place the beaker in the CO_2 trap and adjust so the condenser tip is beneath the surface of the $\text{Ca}(\text{OH})_2$ suspension but not touching the bottom of the beaker. (See Figure 25).

Pipet 0.25 milliliter 6 N HCl into the distillation flask. Drop the weighed sample (a piece of metal weighing between 50 and 100 milligrams) into the flask and allow it to dissolve; this requires only a few minutes. Then add 8 - 10 milliliters purified methanol and immediately connect the flask to the condenser. Distill approximately 45 milliliters purified methanol through the distillation flask into the $\text{Ca}(\text{OH})_2$ suspension, at the same time keeping the volume in the distillation flask essentially constant. This is done by proper control of the Variacs. Lower the receiving beaker so the quartz tip of the condenser is above the surface of the distillate and continue distilling for 20 or 30 seconds to wash the tip. Immediately place the beaker on the steam bath

121

and lower the inverted funnel. (See Figure 26). Start the nitrogen flow and carry out the evaporation in an atmosphere free from carbon dioxide. Remove the beaker immediately upon reaching dryness and allow to cool.

Add 0.25 milliliter 6 N HCl to the beaker, incline and rotate to bring the acid into contact with all the precipitate. This operation is important and requires patience and skill to prevent loss. Next add 0.50 milliliters 0.1 per cent curcumin in 95 per cent alcohol, swirl gently, then add 0.50 milliliters 15 per cent oxalic acid. Again incline and rotate the beaker to bring the reagents into contact with all the wall surfaces of the beaker.

Place the beaker in the drying oven at $55^{\circ}\text{C} \pm 3^{\circ}\text{C}$ and heat 30 minutes beyond the drying time. At the end of this period remove from the oven and allow to come to room temperature. Extract the color from the contents of the beaker with 1 milliliter 95 per cent ethyl alcohol. Filter through a medium porosity sintered-glass filter and catch the clear filtrate in a 3 milliliter volumetric flask. Repeat with successive small portions of alcohol until the color is quantitatively removed. Dilute with additional alcohol to a final volume of 3 milliliters, shake and transfer to a Beckman absorption cell with 1.00 centimeters light path and determine the extinction at 540 millimicrons on the Beckman spectrophotometer.

(8) Procedure for Total Reagent Blank

Repeat the entire procedure omitting the sample but using the same quantities of reagents as in an actual analysis.

The total reagent blank should be between 0.050 and 0.070 extinction units. If the blank is much greater than this value, it is necessary to find the source of the contamination.

(9) Reference

LA-340 (Terminal Report)

8.4-7 Rapid Colorimetric Estimation of Gold in Cyanide Plating Baths

(1) Abstract

By treatment of the solution to be tested with aqua regia, the cyanide is removed and the gold is oxidized. The color intensity of the yellow chloroauric ion serves as a measure of the gold concentration in the solution. Measurements are made against a known standard using a colorimeter. The method is subject to interference by iron or any other impurity which gives color to the solution under the conditions of the test.

(2) Applicability

This procedure has been applied only to solutions containing 15 - 25 grams of gold per liter. Stronger or weaker solutions may be analyzed provided the sample taken gives about 15 - 25 milligrams of gold in the final volume of 25 milliliters, this being the optimum concentration for comparison in the colorimeter.

(3) Accuracy

The accuracy of the procedure was established by comparing results with those obtained by gravimetric gold assay of the same solutions.

The percentage error can easily be held to less than 5 per cent if the concentration of the unknown solution be nearly equal to or greater than that of the standard, and the concentration is in the range 15 - 25 milligrams of gold per 25 milliliters of final volume.

(4) Procedure

See LA Report 416A.

8.5 FLUORIMETRIC PROCEDURE

8.5-1 Fluorimetric Estimation of Microgram Amounts of Uranium

(1) Abstract

The strong greenish fluorescence of uranyl ion in ultraviolet light is used as a measure of its concentration in solution. Cooling to the temperature of dry ice-methanol mixture enhances the fluorescence. The uranium is contained in either concentrated phosphoric or sulfuric acid since they form a clear glass at this temperature. The amount of uranium present is estimated by visual comparison of the intensity of the fluorescence of the sample with that of known standards.

(2) Applicability

The method has been used routinely for the determination of microgram amounts of uranium in plutonium nitrate solutions, and with the modifications to be described, in gunk solutions, ores, and some miscellaneous materials.

(3) Size of Sample and Limit of Sensitivity

Sufficient sample is taken to give not less than 1 microgram of uranium, 10 micrograms being the optimum amount. The limit of sensitivity is about 1 microgram of uranium per milli-

liter of solution.

(4) Reagents

- (a) Phosphoric acid, 85 per cent, c.p. Organic matter is removed by boiling the acid with 30 per cent hydrogen peroxide until it exhibits no fluorescence under test conditions.
- (b) Sulfuric acid, concentrated, c.p. Organic matter is removed as for phosphoric acid.
- (c) Hydrogen peroxide, 30 per cent, c.p.
- (d) Perchloric acid, 70 per cent, c.p.
- (e) Uranyl sulfate, c.p. (For preparation of standards).
- (f) Methanol, absolute, U. S. P.

(5) Apparatus (See Figures 28 and 29).

- (a) Volumetric flasks, pyrex, glass stoppered, 1 milliliter.
- (b) Drying oven
- (c) Hot plate
- (d) Aluminum heating block
- (e) Pocket spectroscope
- (f) Small Dewar flask
- (g) Ultraviolet source. Westinghouse Type A-H6 Lamp (Hg vapor) used with quartz water jacket.
- (h) Mirrored concave reflector, 6 inches diameter
- (i) Metal case housing for lamp
- (j) Solenoid controlled water cooling system
- (k) Quartz lens. plano-convex, 70 millimeters diameter, about 10 inches focal length
- (l) Lens support
- (m) Copper sulfate solution filter -- 3 inches thick

Figure 28

Arrangement for Fluorimetric Estimation of Uranium

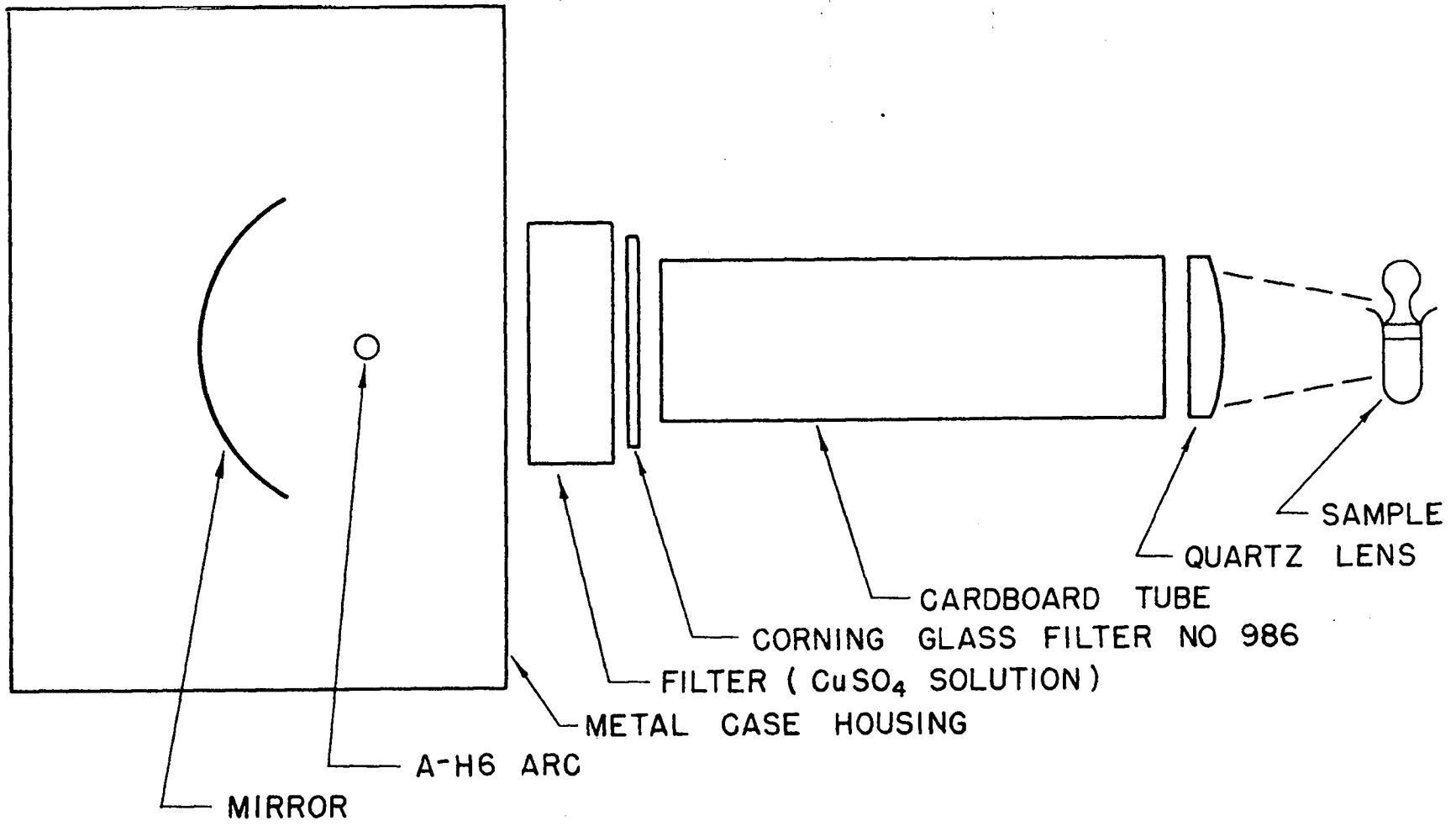
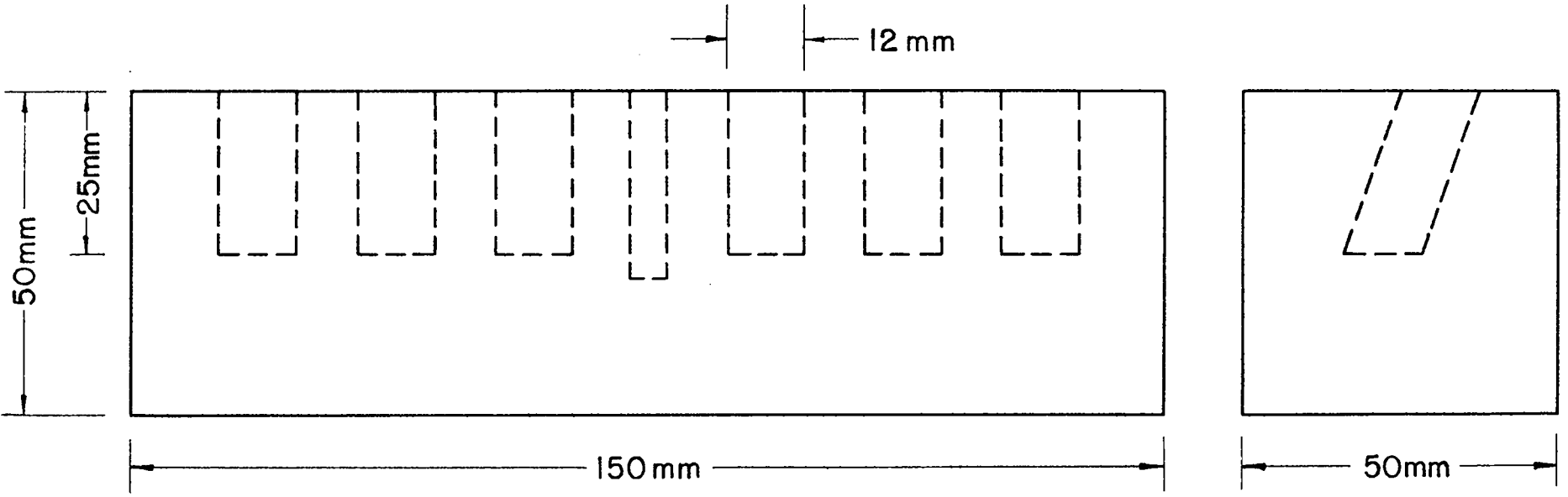

Figure 29
Aluminum Heating Block



- (n) Corning glass filter #986
 - (o) Cardboard tube, 3 inches diameter x 12 inches, to prevent light scattering.
- (6) Preparation of standards
- (a) Prepare a stock uranyl solution by dissolving 0.0864 grams of $\text{UO}_2\text{SO}_4 \cdot 2\frac{1}{2}\text{H}_2\text{O}$ in water and diluting to 1000 milliliters. This solution contains 50 micrograms of uranium per milliliter.
 - (b) Into clean 1 milliliter volumetric flasks transfer by means of micro-pipets aliquots of the stock solution to give two sets each of the following amounts of uranium: 1, 3, 5, 7, 5, 10, 15, and 20 micrograms.
 - (c) Add to each of the above flasks 0.5 milliliters of phosphoric acid ("organic free") and 2 drops of hydrogen peroxide (30 per cent). Place the flasks in the aluminum heating block and heat at about 150° C until evolution of oxygen is complete. Cool and repeat treatment with two more drops of H_2O_2 . Cool and fill to the mark with "organic free" phosphoric acid. Heat about an hour at about 185° C to remove excess water, cool and stopper flasks.
 - (d) Turn on the ultraviolet light and turn off all room light. It is essential that the room be dark. Cool the flask to be examined for 3 - 4 minutes in the dry ice-methanol bath. When sufficiently cooled the solution will solidify to give a clear hard glass with a rather pointed cone shaped meniscus.
 - (e) Look through the pocket spectroscope at an ordinary fluorescent light with the spectroscope held so that the red end of the spectrum is on the left. Adjust the slit width so that the sharp

yellowish green band appears to be about 1 millimeter wide.

- (e) Remove the flask from the bath and hold at the focal point of the ultra-violet light. Examine the fluorescent light emitted by the uranium by looking through the spectroscope held within 1 centimeter of the flask. (18)

(18)

The spectrum of the uranyl ion shows a set of five or six narrow bands, beginning at about 4900 Å and extending toward the red. The second band at about 5100 Å is the most intense, the succeeding bands decreasing steadily in intensity (See IA-15). Visual examination with the pocket spectroscope usually reveals no more than four bands. Those on the right (the violet end of the spectrum) are of a wave length that do not affect the eye as much as those on the left. With less than 2 micrograms of uranium only the two bands on the left may be visible. Therefore, both the number and intensity of the bands are an aid in determining the amount of uranium present.

If organic matter has not been completely removed by the peroxide treatments there will be a uniform green fluorescence over the entire field. This may be strong enough to obscure the uranium bands or merely enough to cause uncertainty of the intensity of the bands due to the green background. In any case it must be completely eliminated for an accurate evaluation of the intensity of the uranium bands. A drop of 70 per cent perchloric acid may be added to help oxidize the organic material.

Nitrate ion is said to quench the fluorescence of the uranyl ion but is effectively removed by the above treatment. The effect of a large number of other ions on the fluorescence of uranyl ion in aqueous solutions has been reported by Einecke and Harms and Sill and Peterson (loc. cit.).

-
- (f) Prepare and study the various standards as above. Preparation of duplicate sets of standards is a good practice when learning the technique since it will help eliminate errors due to faulty preparation. Considerable practice is required and the personal factor is large. Two experienced analysts, however, will usually not be in disagreement by more than 1 microgram over the range 1 to 15 micrograms.

(7) Procedure for Plutonium Nitrate Solutions

Heed Health Safety Rules Outlined in Section 8.2

- (a) Into a clean 1 milliliter volumetric flask pipet sufficient sample to contain about 10 micrograms of uranium.
- (b) Evaporate the solution to dryness at 105° C in an oven.
- (c) Allow the flask to cool and add 2 drops of "organic free" phosphoric acid and 0.5 milliliter of 30 per cent hydrogen peroxide. Heat in the oven at 105° C until the peroxide is removed.
- (d) Repeat the addition and evaporation of peroxide.
- (e) Fill to the mark with "organic free" phosphoric acid and compare the intensity of the fluorescence produced in ultraviolet light with the standards as described above.

(8) Procedure for Ether-Stripped Gunk Solutions

These solutions result from the continuous ether extraction process employed by the uranium (235) recovery group for the recovery of uranium from a wide variety of materials. They usually contain large amounts of magnesium salts and smaller amounts of other miscellaneous salts.

Because of the insolubility of the salts in concentrated acid the uranium must be separated from them before the test is made. This procedure for the separation is fully described in Chapter 2, Section 2.4-6 of this volume. The final comparison with the standards is made as described above.

(9) Procedure for Ores, etc.

- (a) Bring the material into solution by an appropriate method -- acid attack or fusion as may be required. Run the analysis in triplicate, spiking one of the samples with a few micro-

grams of uranium to determine the per cent recovery in the procedure.

- (b) With high silica ores it is best to remove the silica by dehydration and filtration in the usual way since large amounts of insoluble material would be troublesome in the extraction procedure to follow.
 - (c) After removal of the silica, evaporate the solution to remove excess acids and make the solution 3 M in nitric acid. Extract the uranium by shaking the solution in a separatory funnel with an equal volume of ether for 15 minutes. Repeat the extraction two more times, discard the aqueous phase, and evaporate the ether phases to dryness on the steam bath.
 - (d) Take up the residue in a little dilute phosphoric acid and transfer to a 1 milliliter volumetric flask. Remove the water by evaporation in an oven at 105°C, cool, add 0.5 milliliters of 30 per cent hydrogen peroxide and repeat the evaporation. Repeat the peroxide treatment and finally heat with a drop of perchloric acid to remove the last traces of organic matter. Fill to the mark with "organic free" phosphoric acid and determine the uranium as described above.
- (10) Precautions
- (a) The volumetric flasks used must be free of any uranium contamination and should be tested under ultra-violet light before use.
 - (b) The solution must be free of organic matter and nitrates.
 - (c) The solution must be cold when examined as the intensity of the fluorescence decreases rapidly as the solution is allowed to warm.

- (d) Excess water must be removed by heating as described above. Otherwise the solution will crystallize and some of the emitted light will be absorbed and scattered by the crystals.
- (e) The room must be dark, and a few minutes should be allowed for accommodation of the eyes to the darkness before examination of the sample.
- (f) With use, the ultra-violet lamp will weaken and samples will appear to contain less uranium than when examined when the lamp is new. This results in a loss in sensitivity. Furthermore, it makes unwise the practice of memory comparison omitting the use of the standards. With experience, this can be done without appreciable loss in accuracy; but the standards should be examined frequently to assure that the lamp has not weakened considerably.

(11) References

Sill, C.W., and Peterson, H.E., Bureau of Mines Information Circular 7337, August 1945

Eineke, E., and Harms, J., Z Anal. Chem., 99, 123-128, (1934)

Project Report LA-15

8.6 VOLUMETRIC PROCEDURES

8.6-1 Volumetric Determination of Microgram Quantities of Acid-Soluble Sulfide Sulfur

(1) Abstract

The sulfur is distilled as hydrogen sulfide from acid solution and absorbed in an excess of calcium hypochlorite. The sulfide is oxidized to sulfate and the excess calcium hypochlorite is determined iodometrically. Stoichiometric relationships, however, are not borne out experimentally. Quantitative results are obtained by determining the titer

values of the reagents against known quantities of sulfide.

(2) Applicability

The method has been applied to uranium and plutonium metals and is presumably applicable to all materials which are soluble in 2 N HCl and give up their sulfide sulfur as H_2S under such circumstances. The principal application is to metals.

(3) Size of Sample and Limit of Sensitivity

The sample size is determined by the sensitivity required.

The absolute limit of sensitivity is about 1% of S.

(4) Reagents

- (a) $Ca(OCl)_2$: Dissolve 6 - 10 grams calcium hypochlorite, U.S.P., depending on the chlorine content in 250 milliliters distilled water, shake well and filter. Dilute the filtrate to one liter and store in an amber bottle in a dark place. Under these conditions the solution is stable. This solution is approximately 0.1 N. For use on the microgram scale dilute to 0.01 N each day before use and redetermine the titer.
- (b) KI, 0.1 N
- (c) $Na_2S_2O_3$, 0.1 N. Dilute to 0.01 N for use.
- (d) Starch indicator solution saturated with HgI_2 .
- (e) Zinc acetate, 2 per cent.
- (f) Concentrated H_2SO_4 .
- (g) Concentrated HCl.
- (h) Standard Na_2S solution 1 milliliter \approx 1 milligram. Standardize against standard I_2 -KI and $Na_2S_2O_3$.
- (i) Tank nitrogen gas.

(5) Apparatus

- (a) Pyrex still. See Figure 30.
- (b) 1 milliliter buret graduated in hundredths.

Figure 30
Pyrex Apparatus for Sulfur determination.

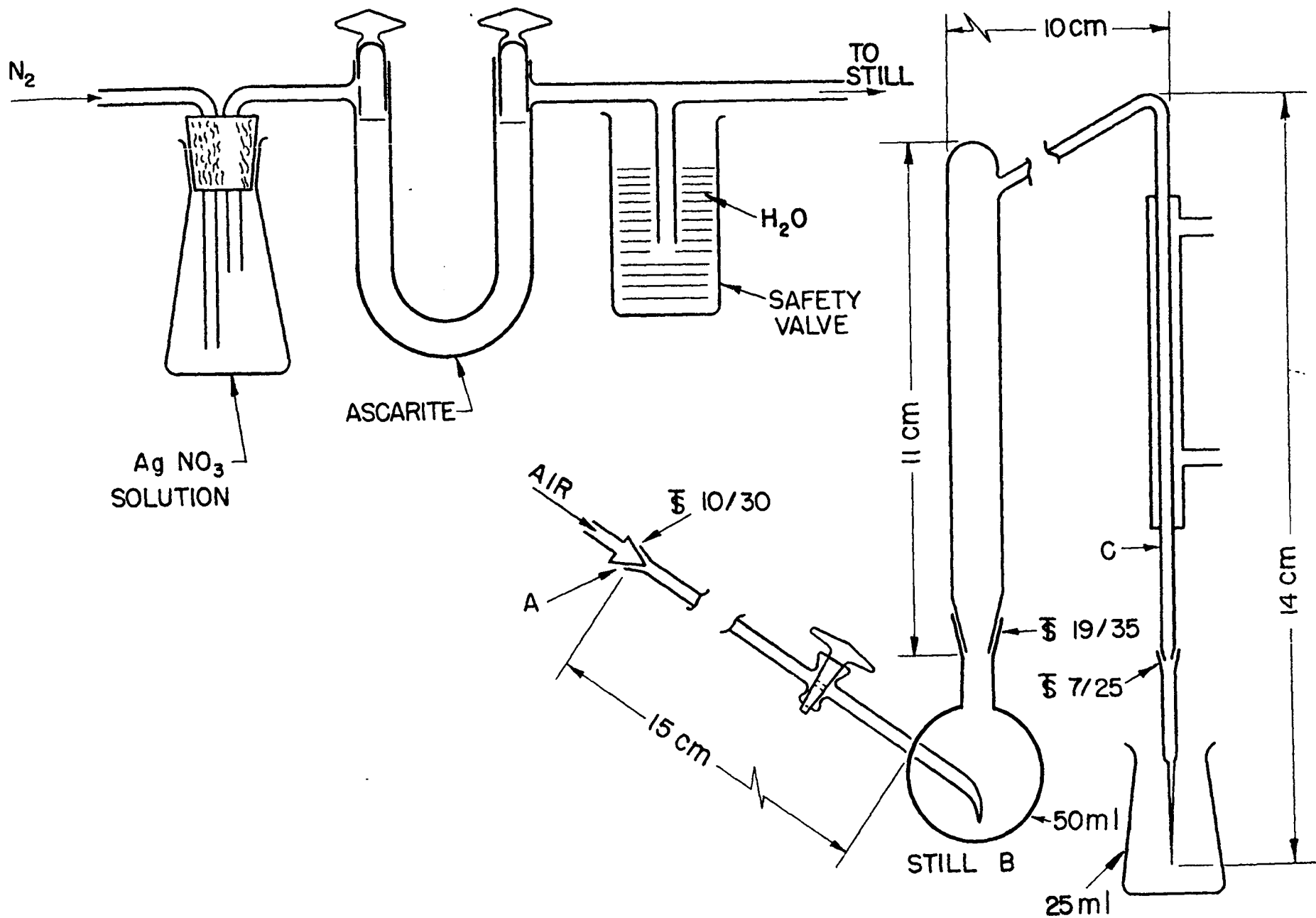

134

- (c) 25 milliliter Erlenmeyer flasks
- (d) Pipets, 5 milliliters, 2 milliliters, 1 milliliter, 100 λ ,
50 λ , 10 λ .
- (6) Procedure

If Plutonium Metal and Its Compounds Are To Be Analyzed,

Obey Health Safety Rules Outlined In Section 8.2

- (a) Determination of titer: To 2 milliliters of 0.01 N hypochlorite solution in a 25 milliliter Erlenmeyer flask, add 100 γ of sulfide sulfur (100 λ of the standard Na_2S solution). Add 2 milliliters of 0.1 N KI and 2 drops concentrated H_2SO_4 . Let the reaction proceed for 3 - 4 minutes to allow the iodine reaction to go to completion. Titrate the liberated iodine with the 0.01 N thiosulfate adding 2 drops of the starch indicator just before the endpoint. Denote this volume of thiosulfate as a. Similarly determine the volume of thiosulfate necessary to titrate the iodine liberated by 2 milliliters of 0.01 N hypochlorite without any added sulfide. Denote this volume of thiosulfate as A.

Then $K = \frac{100 \gamma}{A - a}$ where K is the relative titer value (in $\gamma\text{S/ml}$) for the thiosulfate solution as used in conjunction with hypochlorite.

- (b) Recoveries from the still: (1) Pipet measured amounts of S^{2-} into 2 milliliters of 2 per cent zinc acetate contained in the still pot B (Figure 30) and assemble the still. (2) Pipet 1 milliliter of 0.01 N hypochlorite into the 25 milliliters receiving flask and add a little distilled water so that the tip of the condenser is below the surface of the solution. (3) add sufficient concentrated HCl through A to make the

solution in B approximately 2 N and wash the acid down with a little water. (4) Connect to a source of compressed nitrogen and adjust to a rate of flow rapid enough to prevent sucking back when the still cools. (5) Heat the solution in B to incipient boiling. (6) Allow the gas stream to sweep over the liberated H_2S for 5 minutes. (7) Disconnect the trap C and wash inside and out into the receiving flask with a small quantity of water. (8) Add 2 milliliters of 0.1 N KI and 2 drops of concentrated H_2SO_4 . (9) After 3 - 4 minutes titrate with 0.01 N thiosulfate adding 2 drops of the starch indicator just before the end point.

- (c) Unknowns: Proceed as in b omitting the sulfide and substituting 2 milliliters of water for the zinc acetate. Introduce the weighed sample into the flask, assemble the still and continue as above. Be sure that the sample is in solution before starting the 5 minute sweep interval. Gentle heating below the boiling point is permissible to insure complete solution. Keep the nitrogen stream flowing throughout the entire operation.

(7) Blank Procedure

Determine the blank by running through the distillation procedure without added sulfide. The blank is positive and constant and is apparently caused by the destruction of a small quantity of hypochlorite during the distillation. No blank correction is necessary if the sulfide is added directly to the hypochlorite.

(8) Precautions

- (a) Do not allow the nitrogen stream to pass through too rapidly.

- (b) Keep distillation time short to cut down the blank; 5 minutes is usually sufficient.
- (c) Do not heat to boiling.
- (d) Allow sufficient time for oxidation of iodide by hypochlorite before tetrating.
- (e) Use suitable buret. One of 1 milliliter capacity graduated in hundredths, so that 0.001 milliliter can be estimated, is adequate.

(9) Theoretical

The basic reactions involved are:



The reactions used in standardizing the Na_2S solution are:

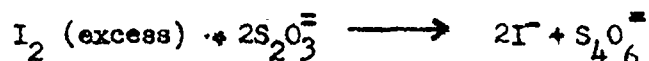
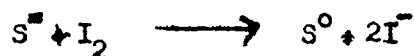

(10) Calculations

Calculate micrograms of sulfide sulfur directly from the volume of thiosulfate used. If X milliliter are used

$$(A - X)K = \mu S^{2-}$$

Express results in ppm.

$$\text{ppm} = \frac{\mu S^{2-}}{\text{sample weight in grams}}$$

(11) References

Kolthoff, I.M., and Sandell, E.B., "Textbook of Quantitative Inorganic Analysis", pp. 587-588, 639-640, New York, The MacMillan Co., 1943

Kolthoff, I.M., and Stenger, V.A., Ind. Eng. Chem., Anal. Ed., 7, 79, 1935

8.6-2 Volumetric Determination of Sulfate Sulfur In Plutonium Materials

(1) Abstract

The sulfate is reduced to sulfide by means of a reducing mixture composed of hydriodic acid, hypophosphorous acid and hydrochloric acid. The hydrogen sulfide is trapped in ammoniacal cadmium chloride solution and the sulfide sulfur is then determined iodometrically.

(2) Applicability

The method has been applied to plutonium nitrate solutions and is presumably applicable to other plutonium solutions and to all plutonium materials that can be put into solution without loss of sulfur.

(3) Range

Sufficient plutonium solution is taken to give approximately 1 milligram of sulfide sulfur or 3 milligrams of sulfate. Satisfactory results can be obtained in the range 0.3 milligram to 5 milligrams of sulfur.

(4) Reagents

- (a) Reducing mixture. Mix 160 milliliters HI (47 per cent), 160 milliliters concentrated HCl and 40 milliliters $H(H_2PO_2)$ (30-32 per cent). Add a few glass beads and boil for 5

minutes. Cool and store in a brown, glass-stoppered bottle.

- (b) HCl, concentrated.
- (c) HClO₄, 70 per cent.
- (d) I₂-KI solution, 0.1 N
- (e) Na₂S₂O₃, 0.01 N.
- (f) Standard Na₂S solution, 1 milliliter = 1 milligram S.
- (g) Starch indicator
- (h) Ammoniacal CdCl₂. Dissolve 10 grams CdCl₂·2H₂O in distilled water, add 500 milliliters NH₄OH and dilute to 5 liters.
- (i) Tank nitrogen gas.

(5) Apparatus

- (a) Distillation equipment. See Figure 31.
- (b) Iodine flasks, 250 milliliters.
- (c) Buret, 5 milliliters, graduated in hundredths.
- (d) Pipets, 1 milliliter, accurately calibrated.
- (e) Pipets, 50 λ, 100 λ .
- (f) Graduated cylinders, 5, 25, 50, 250 milliliters.
- (g) Evaporating equipment. See Figure 32.

(6) Standardization of Reagents

- (a) Standardize the 0.1 N I₂-KI solution against arsenious oxide in the usual way.
- (b) Standardize the 0.01 N sodium thiosulfate by carrying 1 milliliter of the standard sulfide solution through procedure a as described below. The resulting titer is then a relative value with respect to the iodine solution and the known amount of sulfide. The blank correction is also eliminated by this procedure.

Assuming 1.000 milliliter of 0.1000 N (0.1000 meq.) of

Figure 31
Distillation Apparatus

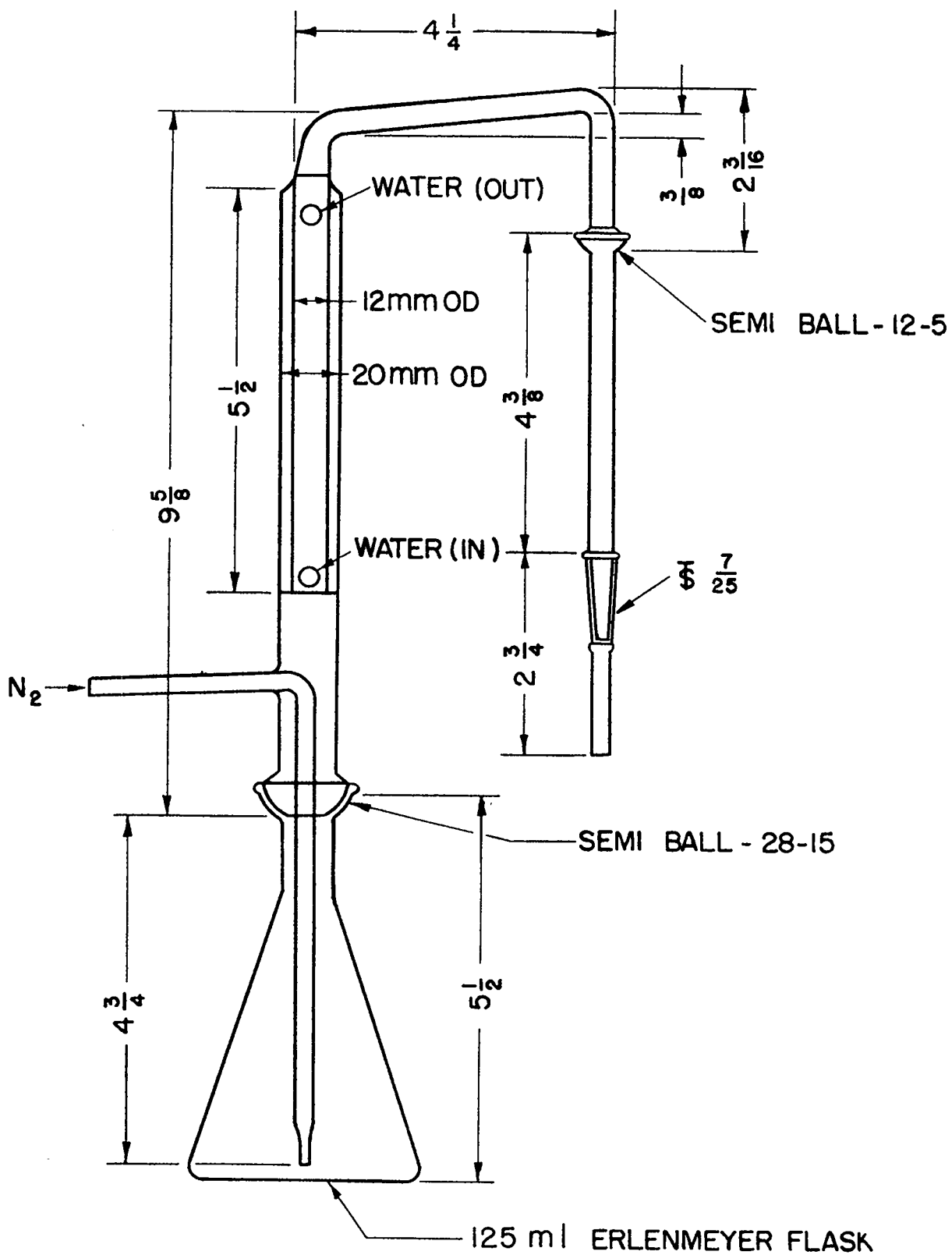
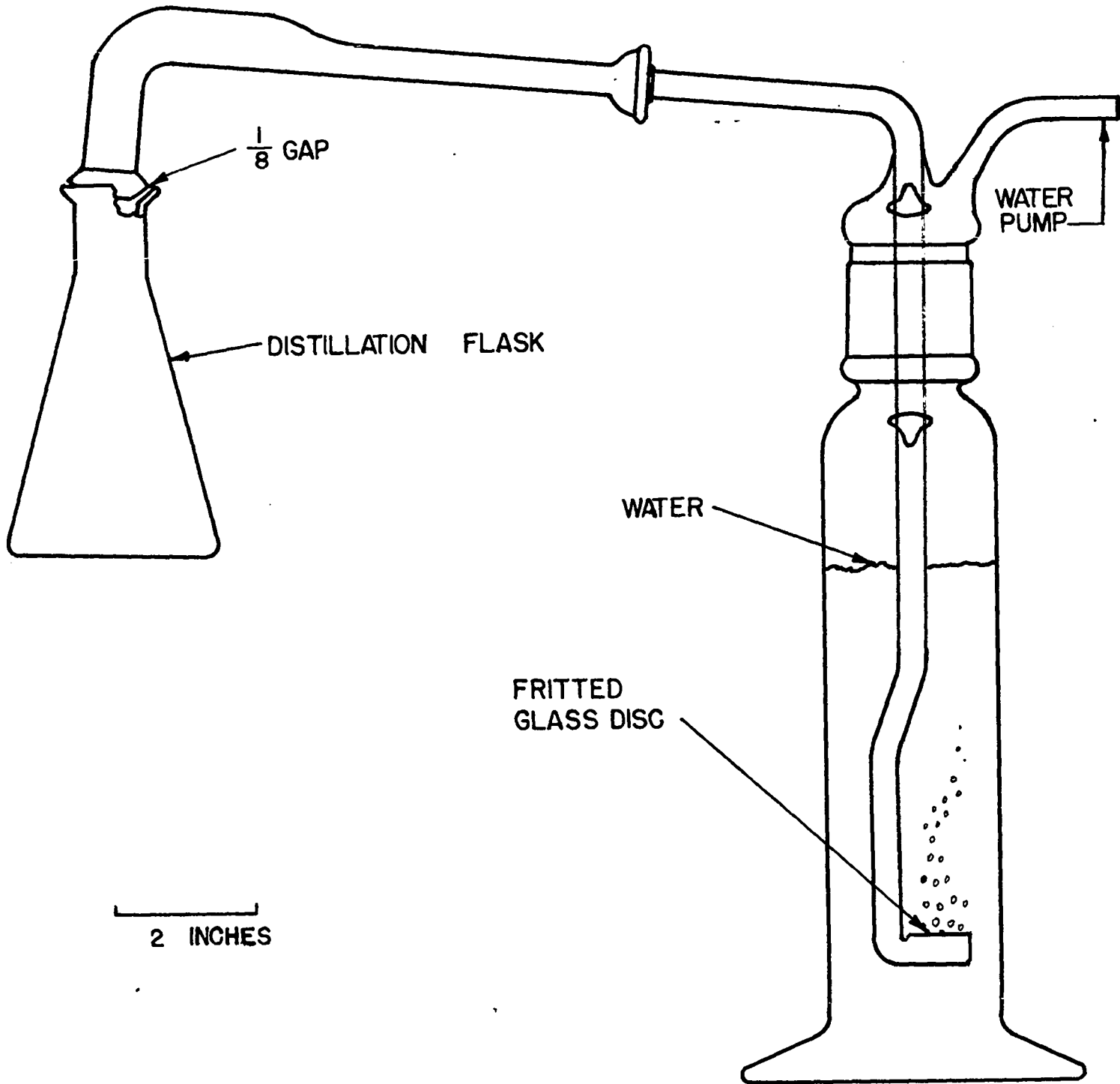

Figure 32
Evaporation Apparatus



APPROVED FOR PUBLIC RELEASE

APPROVED FOR PUBLIC RELEASE

iodine and 1.000 milligram (0.0625 meq.) of sulfide are used,

$0.1000 \text{ meq.} - 0.0625 \text{ meq.} = 0.0375 \text{ meq.}$ of excess iodine.

If n is the number of milliliters of thiosulfate used in titrating the excess iodine, then the normality of the thiosulfate is

$$N = \frac{0.0375}{n}$$

(7) Procedure

Head Health Safety Rules Outlined in Section 8.2

(a) In the absence of nitrate:

Place 50 milliliters of the ammoniacal cadmium chloride solution in the 250 milliliter iodine flask and place in position with the end of the delivery tube touching the bottom of the flask. Pipet an aliquot of the unknown (containing approximately 1 milligram of S) into the distillation flask, add a few glass beads and 20 milliliters of the reducing mixture. Immediately connect the flask to the still. Place the heater in position and bring to a rapid boil. When no more H_2S comes over (approximately 10 minutes), start nitrogen bubbling through the boiling solution at a gentle rate. Pass the nitrogen through for 10-15 minutes.

At the end of the distillation, disconnect the delivery tube at the semi-ball joint and wash down the inside with a few milliliters of water. Disconnect the lower part of the delivery tube at the standard taper joint and leave the lower part in the receiver. Remove the heater and stop the gas stream.

142

Add 10 milliliters concentrated HCl to the cadmium sulfide solution in the iodine flask, stopper immediately, swirl to mix and place in an ice bath. When the solution is cold, remove from ice bath and pipet 1 milliliter of the iodine solution into the cup of the iodine flask. Cautiously loosen the stopper so that the iodine is drawn into the flask without allowing any of the H_2S to escape. Wash the iodine into the flask with small portions of distilled water being careful at all times not to remove the stopper completely. The partial vacuum will draw in the wash water without difficulty.

Shake the flask well so that all the H_2S will react with the iodine. Allow the flask to come to room temperature with occasional shaking. Titrate with the thiosulfate to the disappearance of the blue starch color, adding the starch indicator just before the endpoint.

If more than 1.5 milligrams of S^{2-} are present add 2 milliliters of the iodine solution. 1 milliliter of 0.1 N I_2 -KI is equivalent to 1.6 milligrams sulfide sulfur.

(b) In the presence of nitrate:

Nitrate interferes seriously with the procedure. Traces of nitrate will produce low results. To eliminate nitrate, evaporate the solution with 5 milliliters of 70 per cent perchloric acid. Boil the solution vigorously to drive off all traces of nitrate. A criterion of sufficiently vigorous boiling is that no $HClO_4$ condenses in the distillation flask. A convenient apparatus for the evaporation is shown in Figure 32. Do not close the semi-ball joint completely but clamp it so that a small gap is left between the male and female parts of the joint.

Evaporate the solution until the volume is decreased to 1 - 2 ml. This will remove the nitrate in one evaporation. The residual perchloric acid will not react explosively with the reducing mixture. Cool the flask and proceed with the distillation as described above.

(8) Precautions

- (a) Do not pass the nitrogen through the solution too rapidly.
- (b) Nitrate must be quantitatively removed.

(9) Calculations

If x milliliters of 0.01 N thiosulfate are used to titrate the excess iodine when 1 milliliter of 0.1 N iodine is added, then:

$$[0.1 \text{ meq.} - (x \cdot 0.01)] 16 = \text{mg. S}^{\bullet}$$

$$\text{mg. SO}_4^{\bullet} = \text{mg. S}^{\bullet} \times 2.99$$

(10) References

Luke, C.I., Ind. Eng. Chem., Anal. Ed. 6, 602 (1934)

LAMS-234

LAMS-249

LAMS-261

8.6-3 Microvolumetric Assay of Plutonium

(1) Abstract

Plutonium as sulfate in 2N H_2SO_4 is reduced to +3 valence with zinc amalgam under a CO_2 atmosphere and is titrated potentiometrically to +4 valence with ceric sulfate.

(2) Applicability

The method has been used primarily for mixtures of +4 and +6 nitrate in 1 N HNO_3 , particularly for Hanford material both as received and after purification. The method permits direct determination of Pu in a soluble sample provided the cations of Ti, V, Fe, Mo, W, and U are present in amounts not greater than 0.02 - 0.03 per cent. If any one of these ions is present in appreciable amount it must either be removed or determined separately and subtracted (using the proper equiva-

144

lent weight factor) from the quantitative combination.

The procedure here given treats Pu nitrate solutions which require a correction for iron only.

(3) Method of Sampling

Aliquots are taken by weight or volume as required; three aliquots containing from 1 to 10 milligrams of Pu are taken for assay and two aliquots are used for determination of iron.

Regardless of precautions taken in storing the sample in solution, the concentration increases because of decomposition of water by alpha particles. The magnitude of this effect is related to the concentration of Pu in the solution. It was calculated for one sample to be about 0.1 per cent per week, but was found, in combination with other effects, to be somewhat greater. This effect prevents a gas-tight seal of samples containing as much as 200 milligrams Pu per milliliter. For this reason aliquots are taken within a few hours from the time the sample is received.

(4) Reagents

- (a) H_2SO_4 , concentrated.
- (b) H_2SCl_4 , 1 N.
- (c) Ceric sulfate, about 0.02 N in 1 N H_2SCl_4 . (19)
- (d) Saturated zinc amalgam.
- (e) Solid CO_2

(5) Apparatus

- (a) Detachable syringe pipet controls for transferring all Pu solutions and for filling and emptying the burets.

(19)

Standardize with Bureau of Standards $Na_2C_2O_4$.

- (b) Transfer weight-pipets with waxed tips (Figure 33).
- (c) Volumetric pipets, waxed tip, calibrated to contain 20 to 100 λ (Figure 33). These pipets are very simply constructed from pyrex glass tubing or small test tubes. The construction at the meniscus is fine enough so that a variation of 1 millimeter does not correspond to more than 0.1 per cent of the pipet volume.
- (d) Platinum crucibles, 8 milliliters.
- (e) Evaporation chamber (Figure 34).
- (f) Infra-red lamp and Variac.
- (g) CO₂ generator. A satisfactory generator consists of a Dewar flask of one liter volume or larger whose heat conduction is sufficient to supply 1 to 2 milliliters of CO₂ gas per second when the flask is half filled with solid CO₂. Heat conduction may be increased by inserting a copper rod through the stopper. The flask should be completely wrapped or taped for the protection of the operator. A combination safety-trap and CO₂ pressure indicator is attached to a side arm of the CO₂ supply line. It consists of an open-end section of the line immersed to a depth of 6 to 8 inches in water. The operating pressure is maintained at about 6 inches of water by an appropriate selection of diameter and length of the capillary leads in the apparatus (Figure 36).
- (h) Combination reduction-titration cups (Figures 35, 36, 37, and 38).

Figure 33
Micro Pipets

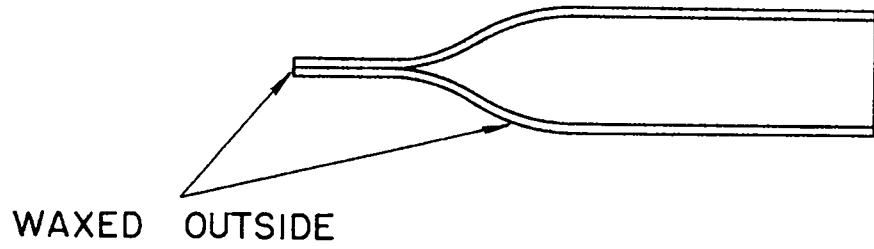

A

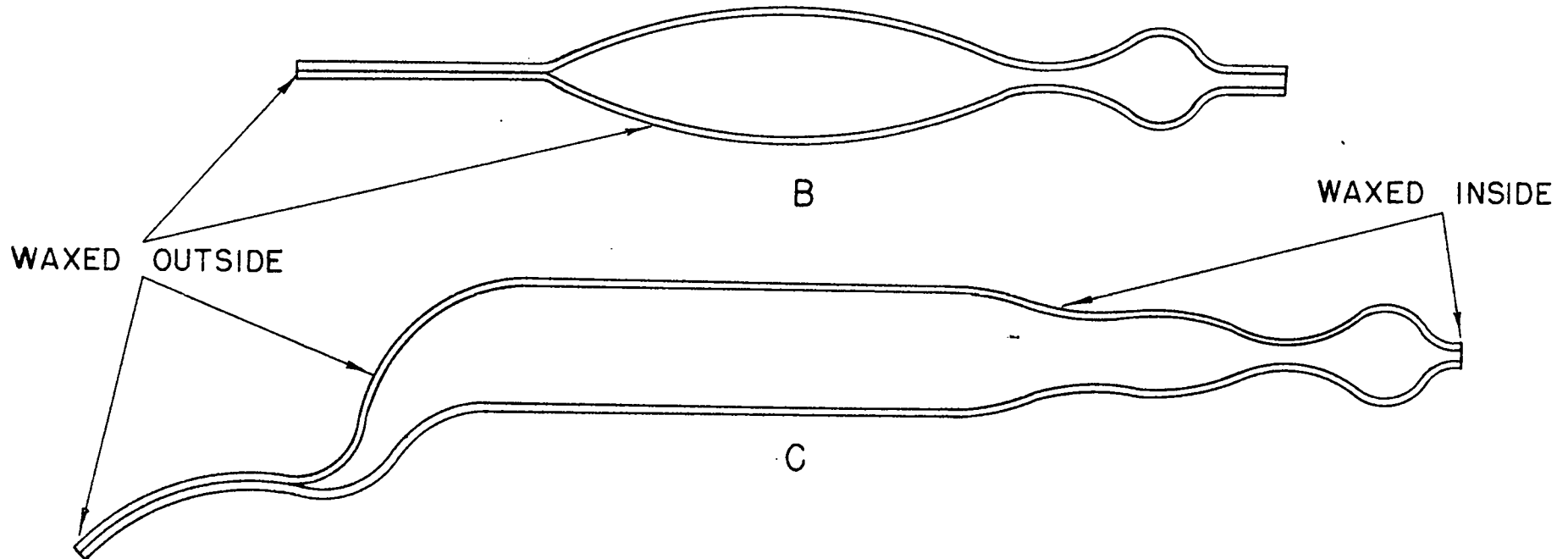
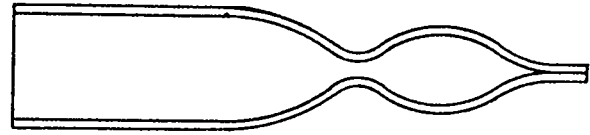

B

C

Figure 34
Evaporation Chamber

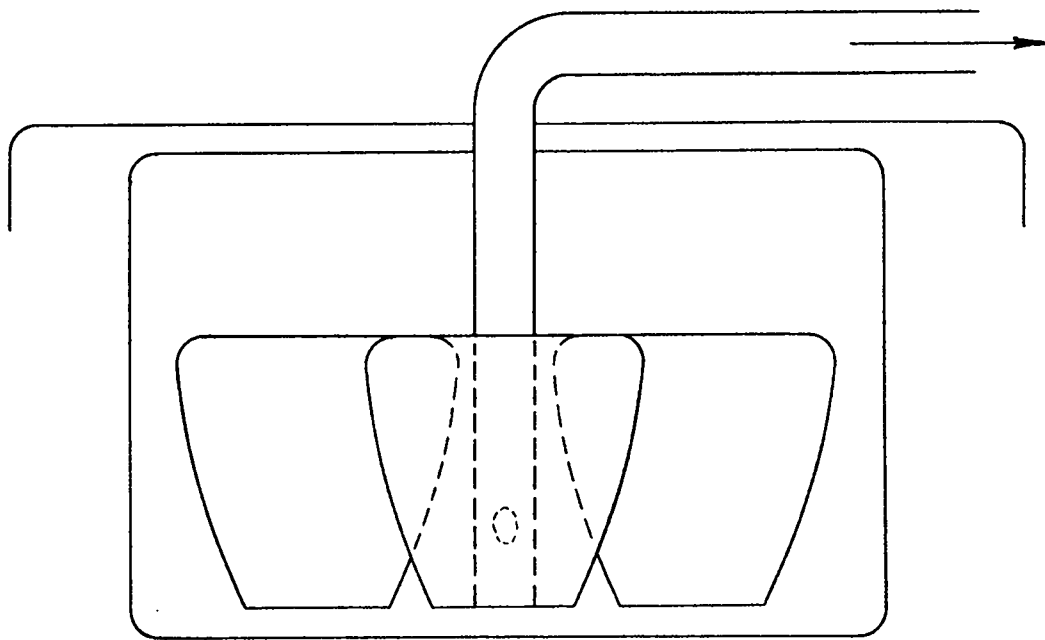
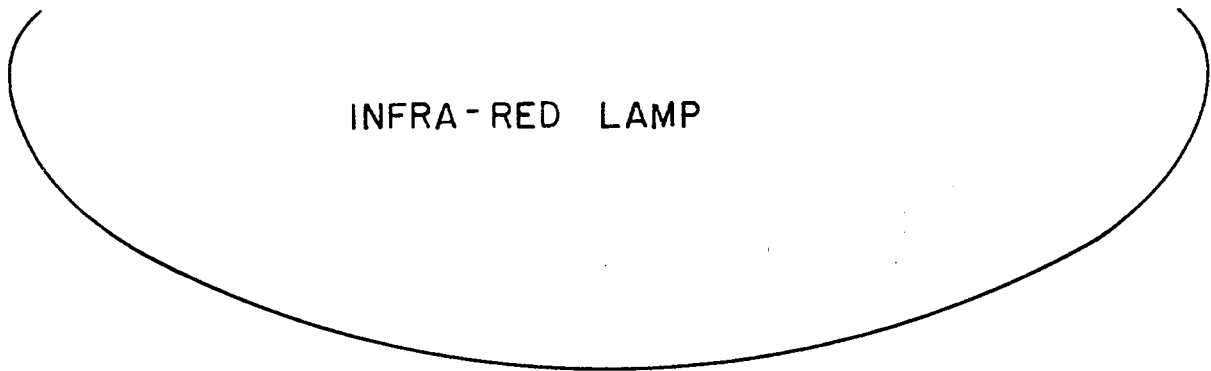

FILTER TRAPS
AND AIR LINE

APPROVED FOR PUBLIC RELEASE

APPROVED FOR PUBLIC RELEASE

Figure 35
Combination Reduction-Titration Cups

APPROVED FOR PUBLIC RELEASE

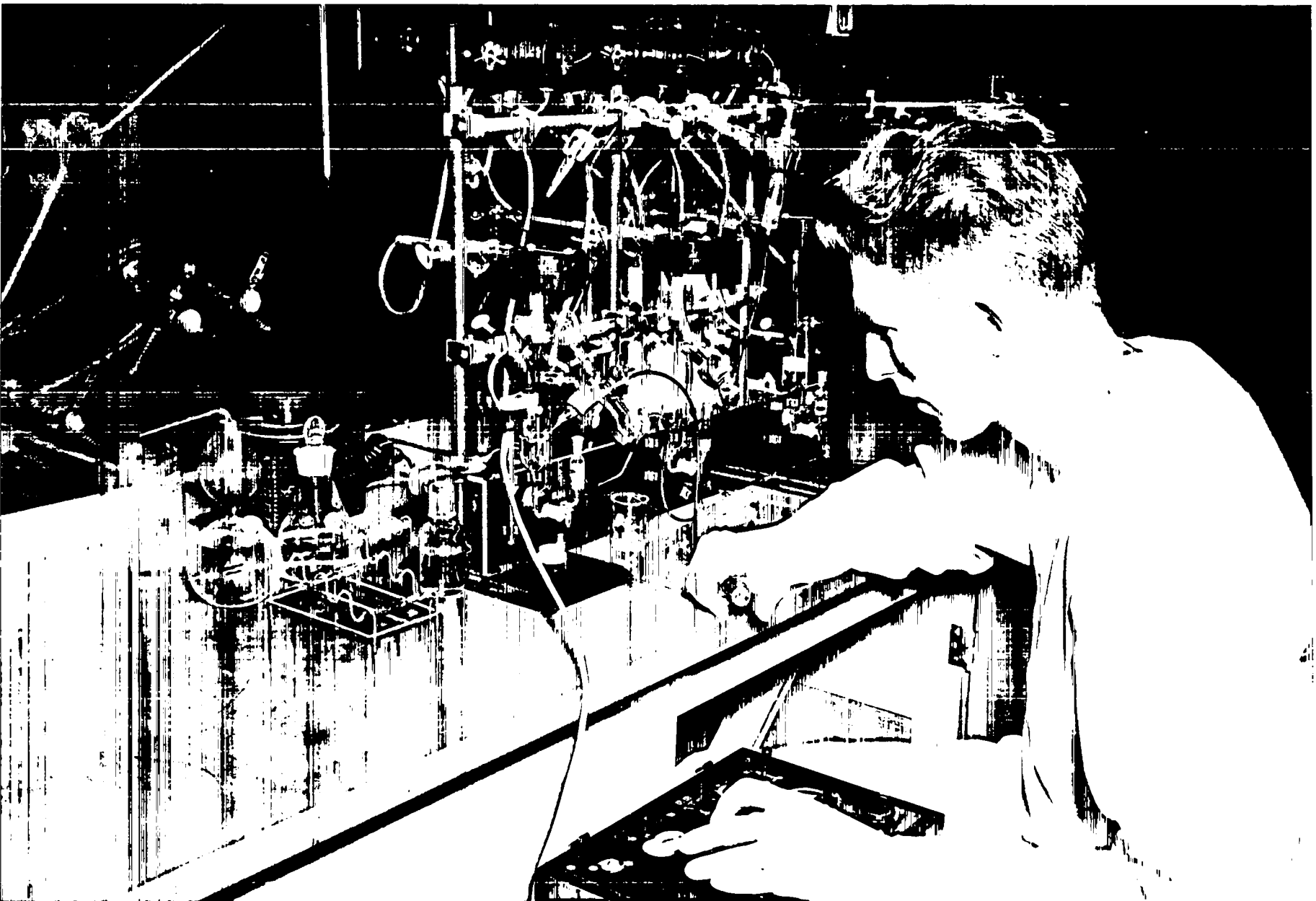

APPROVED FOR PUBLIC RELEASE

Figure 36
Reduction-Titration Cup

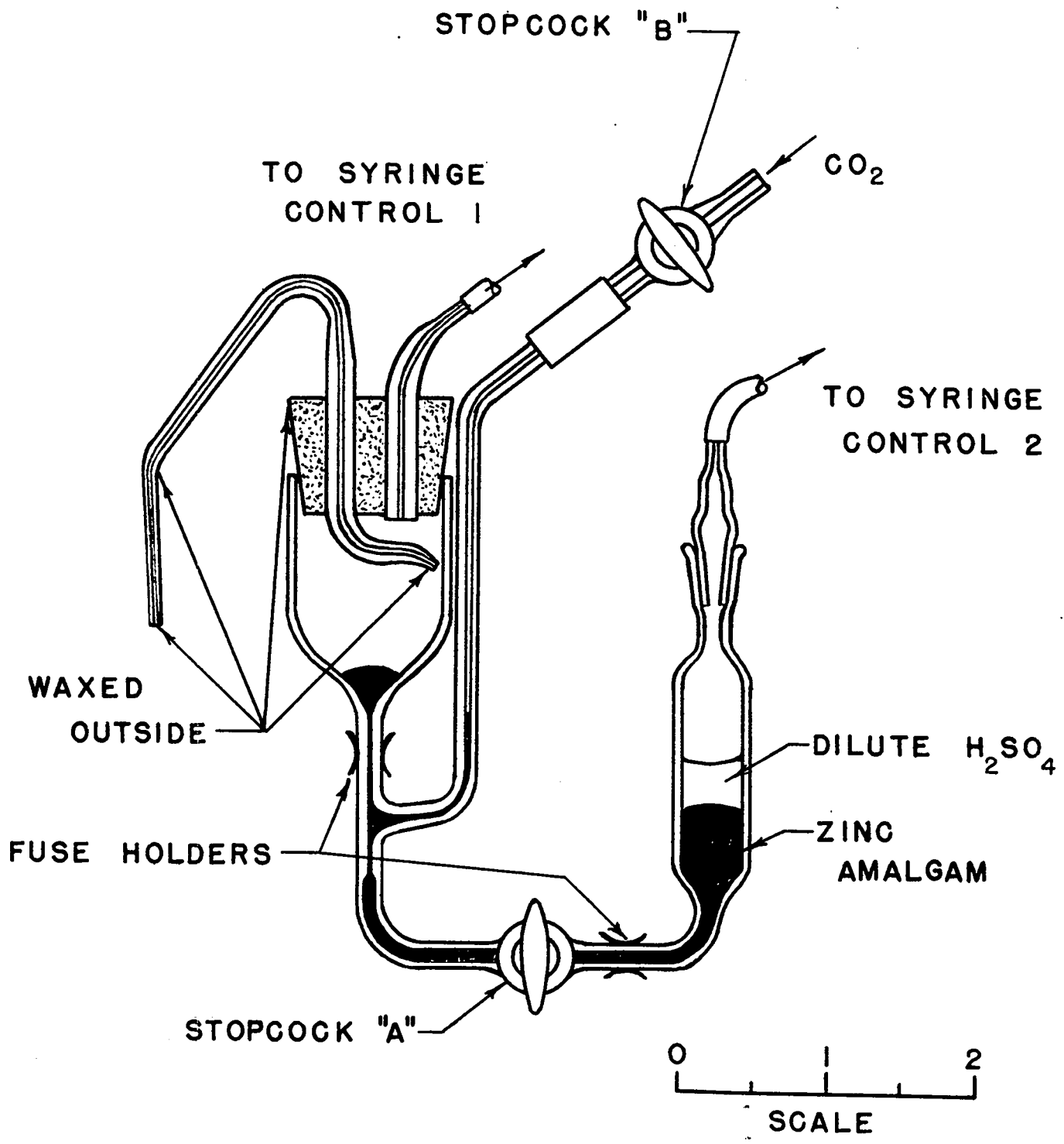

- (i) Variable speed electric stirring motor, Variac, and waxed glass stirrers.
 - (j) Weight-burets, 0.5 to 3.0 milliliters capacity (Figure 33). This tip is waxed outside so that it will not be wet by water solutions. This minimizes loss in weight caused by evaporation and also, for small bore tips, prevents a solution from draining from the buret except when it is forced with a syringe or when the tip is immersed in a solution. The control construction is waxed inside so that it will not fill with solution and thus prevent gravity drainage when the tip is immersed. If the same buret is used for the end point as for the rest of the titration its delivery rate with the tip immersed should not exceed 2 milligrams of solution per second.
 - (k) Vacuum residue bottle. The liquid lead is a tapered 2 millimeter glass tube attached to the bottle by an adequate length of rubber tubing. The vacuum lead contains a cotton filled drying tube.
 - (l) Beckman pH meter with calomel and platinum electrodes.
- (5) Procedure

heed Health Safety Rules Outlined in Section 8.2

- (a) For weight aliquots weigh by difference the required amount of sample using a clean dry transfer pipet. Transfer the aliquots to 8 milliliter platinum crucibles. For volume aliquots use clean dry pipets calibrated "to contain". After discharging the volume aliquot into the crucible, rinse the pipet once with 1 N H_2SO_4 and twice with water, adding all rinses to

the crucible. Dry the pipet on a vacuum manifold and reserve for future use. Add carefully around the side of the crucible 150 λ of concentrated H_2SO_4 and enough water to give a volume not less than 0.5 milliliter. Place these crucibles in the evaporation chamber.

With a steady stream of air passing through the chamber, the samples with an infra-red lamp at a temperature somewhat below the boiling point of the solution. When most of the water is driven off and the rose-colored $+4$ sulfate has precipitated, increase the temperature until the H_2SO_4 fumes. Turn off the lamp and allow the samples to cool. When cool add carefully around the crucible rim enough water to re-dissolve the $+4$ sulfate precipitate; 0.4 to 0.5 milliliter should be enough. Repeat the fuming and dilution.

- (b) If the reduction-titration cups have not been used for some time clean them thoroughly. Dry the stopcocks and grease them lightly.

With a stopcock "A" (Figure 36) open add 1 milliliter of dilute H_2SO_4 to the amalgam reservoir. Charge the reservoir with enough saturated zinc amalgam to bring the level of the amalgam to the CO_2 side arm.⁽²⁰⁾ Open stopcock "B" and force

(20)

An excess of zinc may be added to this reservoir in order to maintain the saturated amalgam.

the dilute acid out of the capillary into the cup. It might be necessary to lower the amalgam slightly with the syringe control. With the CO_2 flowing,⁽²¹⁾ transfer the dilute acid

(21)

The CO_2 capillary should be fine enough to permit the regulation of the gas flow to a slow rate so that spray of plutonium solution is minimized.

to the residue bottle.⁽²²⁾ Close stopcock "B" and raise

(22)

A separate residue bottle is kept for second rinses and solutions of this kind, thus eliminating excessive dilution of recoverable residue.

the amalgam to a height of about 0.5 centimeters in the cup. Close stopcock "A". Place the syphon stopper in the position shown (Figure 36) and slowly draw the dissolved sample from the platinum crucible into the cup. In order to minimize spray, draw the last portion over very slowly or allow the syphon lead to remain filled. Rinse the crucible and lead with 2 milliliters of 1 N H_2SO_4 in three portions. Remove the syphon stopper and place the plastic lid (Figure 37) on the cup. Raise the amalgam to a height of about 1.0 centimeter in the cup. Insert the CO_2 lead through the lid. Adjust the stirrer with the flattened portion half immersed in the amalgam. Stir at a moderate rate for one-half hour or longer.

- (c) Turn on the pH meter and set the range switch to "+MV".
- (d) Fill the buret with more ceric solution than is required to oxidize the sample. Weigh the filled buret to the nearest 0.1 milligram. Stop the stirrer. Lower the amalgam to the level of the CO_2 side arm. Open stopcock "B" to a minimum flow rate. Adjust the pressure in the amalgam reservoir with the syringe control so that the CO_2 passage is alternately locked and opened by the oscillating amalgam column. When the reduced solution has been raised into the cup and the capillary between the cup and side arm is completely filled with CO_2 , close stopcock "B". The pressure in the reservoir should be

Figure 37
Reduction Assembly

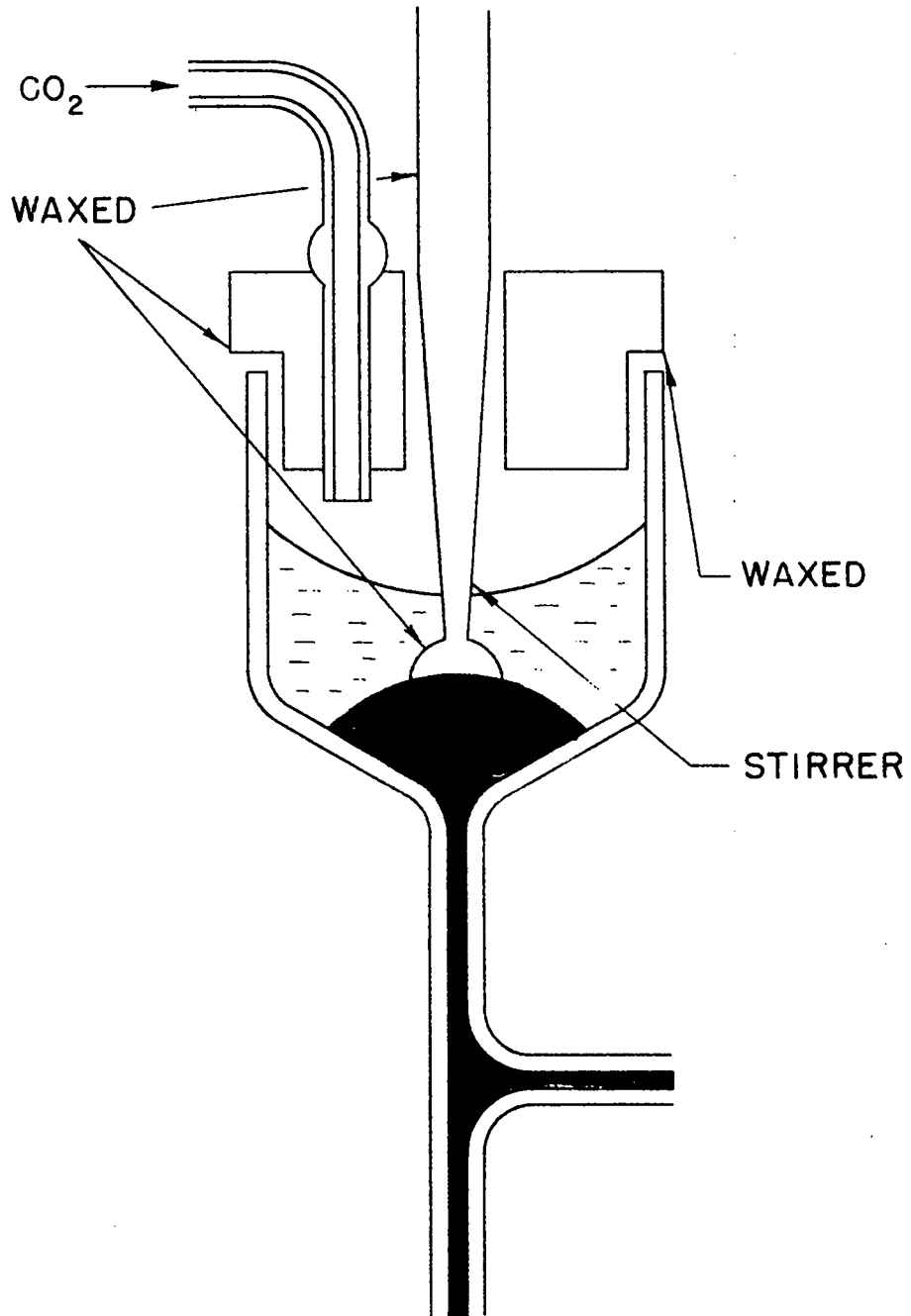

19

- sufficient to just lock the CO_2 passage. Close stopcock A. If any amalgam has been retained in the solution, the above operation must be repeated until the separation is accomplished.
- (e) Remove the lid and CO_2 lead. Rinse the electrodes and lower them into the reduced solution. Titrate with stirring to within a few per cent of the end point -- between 600 and 650 millivolts. Continue the stirring for at least ten minutes or until a reasonably steady potential is attained. As much as 95 per cent of the ceric solution may be force drained with a syringe control. The last 5 per cent or more should be added in small portions by touching the buret tip to the surface of the solution. The end point potential is between 750 and 780 millivolts cell potential but should be determined by each operator from a titration curve. Interpolation of the end point is possible to 0.1 per cent from any potential between 700 and 820 millivolts provided a satisfactory curve has been obtained. With some practice only an initial and final weight are required.
- (f) When the titration is completed transfer the solution to the vacuum residue bottle. Rinse the cup and capillary. While the apparatus is not in use store it with stopcock B closed, the cup filled with distilled H_2O or dilute H_2SO_4 , the plastic lid on the cup and 0.5 milliliter of dilute H_2SO_4 over the amalgam in the reservoir.

(6) Blank Procedure

Determine the reagent blank in the presence of plutonium in the following way. Take aliquots ranging from 0.01 to 0.10 milligrams of plutonium and several aliquots of about 5 milligrams. These are all taken from the same stock solution or

accurate dilutions of the stock solution, and are treated according to Procedure outlined above. Since their ratios to each other are accurately known and since the blank is a very small fraction of the 5 milligram samples and an appreciable fraction of the smaller ones, the value obtained in the 5 milligram sample may be assumed correct for the purpose of calculating the amount in the smaller samples. The difference between this calculated amount and the observed amount in the small samples is the reagent blank correction. It should not exceed 10% of plutonium and should be reproducible to 2 or 3%.

(7) Precautions

- (a) See Method of Sampling concerning errors resulting from storage of the sample.
- (b) Although the plutonium is quantitatively reduced in less than one-half hour the minimum time should be determined not only by this consideration but by the length of time required to free the system from O_2 . This is necessary in order to obtain a low and constant blank.
- (c) Pu^{+3} is slowly air oxidized to Pu^{+4} . The error is negligible if the titration is performed without interruption according to Procedure (d) and (e).
- (d) At temperatures below $20^{\circ}C$ the reaction is rather slow. In any case the end point must be determined or interpolated from steady (not rising) potential readings.

- (e) If a falling end point is observed examine the capillary below the titration cup. Evolution of hydrogen gas from the dilute acid film in contact with the amalgam may be enough to raise the amalgam into the capillary. Effective contact of the amalgam with the partially oxidized sample will of course make the results worthless.
- (f) If the potential rises above 820 mv, back titrate with ferrous reagent. This reagent may be standardized by adding an excess of the ceric solution at a satisfactory endpoint and back-titrating with the ferrous solution.
- (g) Erratic balance behavior and significant errors in weight have been observed when one attempts to deliver small amounts of solution accurately from relatively large burets handled with rubber gloves. The effect disappears when the burets are held with clean, dry fingers or cotton gloves and for this reason the rubber glove is removed for initial and final weighings.

(8) Correction for Iron

The procedure for determination of iron is described in Section 8.4-3. The requirement that the weight concentration of iron when multiplied by 4.28 (the equivalent weight ratio) be uncertain by not more than 0.1 per cent of the total plutonium concentration is satisfied by this method.

(9) Precision and Accuracy

Average deviations from the mean of 0.1 per cent are usual, of ≤ 0.05 per cent accidental, and of > 0.2 per cent rather unusual. Accuracy is demonstrated to a certain extent

157

by results on plutonium metal and tetrafluoride. The former assayed 99.9 per cent plutonium with a standard deviation of 0.17 per cent on 14 aliquots of one portion and 0.19 per cent on 6 aliquots of another portion. No results were rejected in calculating the standard deviation. The tetrafluoride assayed 100.07 per cent pure with a standard deviation of 0.07 per cent.

(10) Calculations

$$\text{Apparent mg. Pu/g. solutions} = \frac{(\text{wt. of ceric solution in g.}) \times T}{(\text{wt. of aliquots in g.})}$$

T = mg. Pu per gram of ceric solution

$$\text{Corrected mg. Pu/g. solution} = (\text{apparent value}) - (4.28 \times \text{mg. Fe/g. Sol'n})$$

(11) References

LAMS-155	LAMS-276
LAMS-190	LAMS-288
LAMS-217	LAMS-507 (Terminal Report)

8.6-4 Microvolumetric Assay of Uranium

(1) Abstract

Uranium as the +6 sulfate is reduced to the +4 state by means of zinc-amalgam. The +4 uranium is then titrated with standard ceric sulfate using a micro-weight buret. The end point is determined by using orthophenanthroline-ferrous complex as an indicator.

(2) Applicability

The method has been applied to uranium samples which do not contain plutonium. If iron is present, it must be determined separately and the titration result corrected accordingly.

(3) Range and Accuracy

From 0.1 milligrams to 5 milligrams of uranium can be determined by the method here described. Best results are obtained with 1 milligram samples. In the analysis of uranyl sulfate controls the maximum observed deviation from the true value was 8%. The average deviation in 17 analyses was less than 1%.

(4) Reagents

- (a) 2 N sulfuric acid.
- (b) 0.1 N potassium permanganate.
- (c) 4 per cent zinc amalgam.
- (d) Standard ceric sulfate, 0.02 N. ⁽²³⁾

 (23)

Standardize by weight against Bureau of Standards sodium oxalate.

- (e) Carbon tetrachloride.
 - (f) Orthophenanthroline-ferrous indicator, approximately 0.01 M.
 - (g) Dry ice.
 - (h) Concentrated H_2SO_4 .
 - (i) Concentrated HNO_3 .
 - (j) Concentrated $HClO_4$.
- (5) Apparatus
- (a) Titration cup (Figure 39)
 - (b) Microweight burets
 - (c) Syringe pipet controller for filling burets.
 - (d) CO_2 generator with outlets for titration cup and wash

Figure 38
Titration Assembly

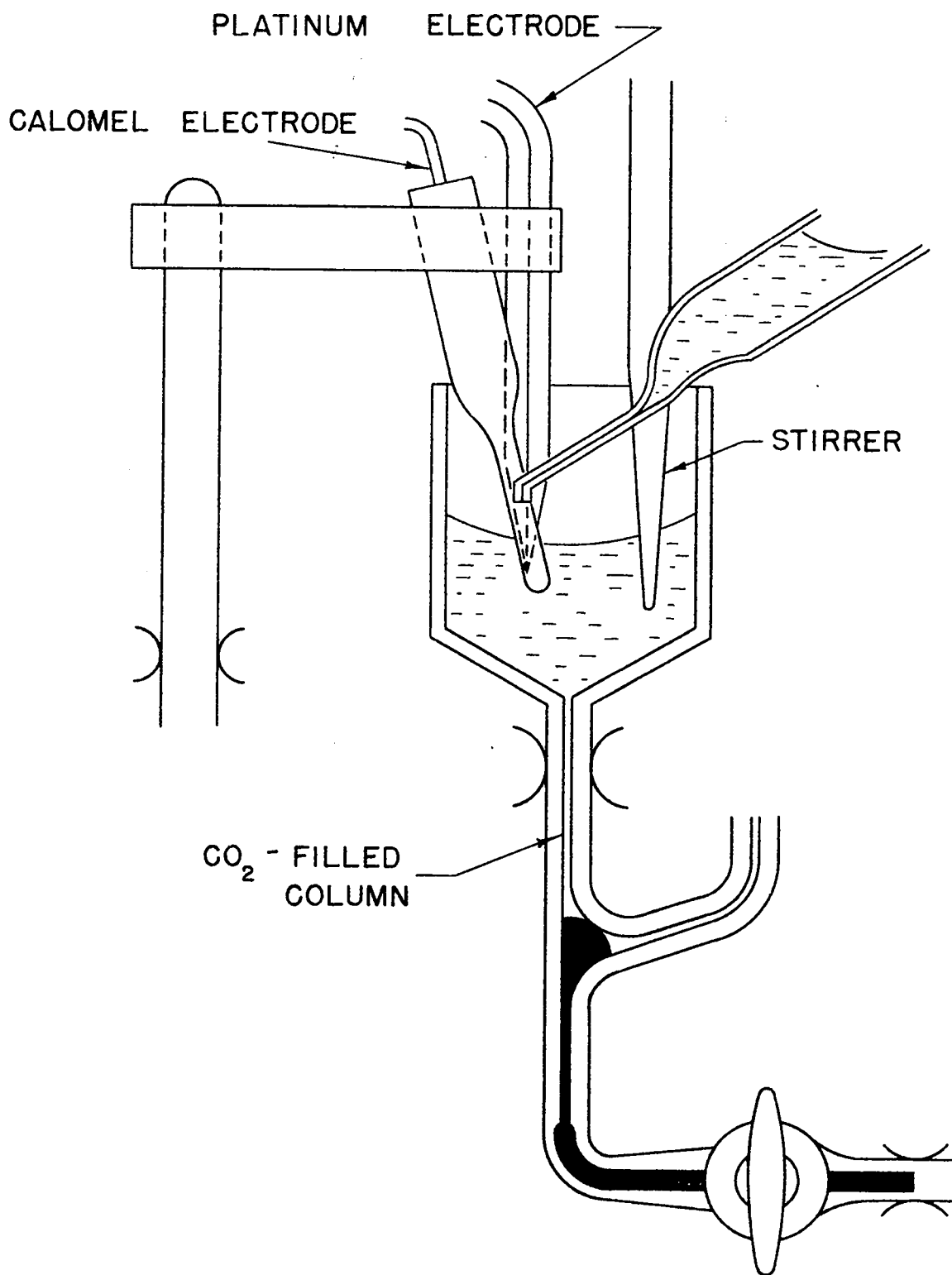
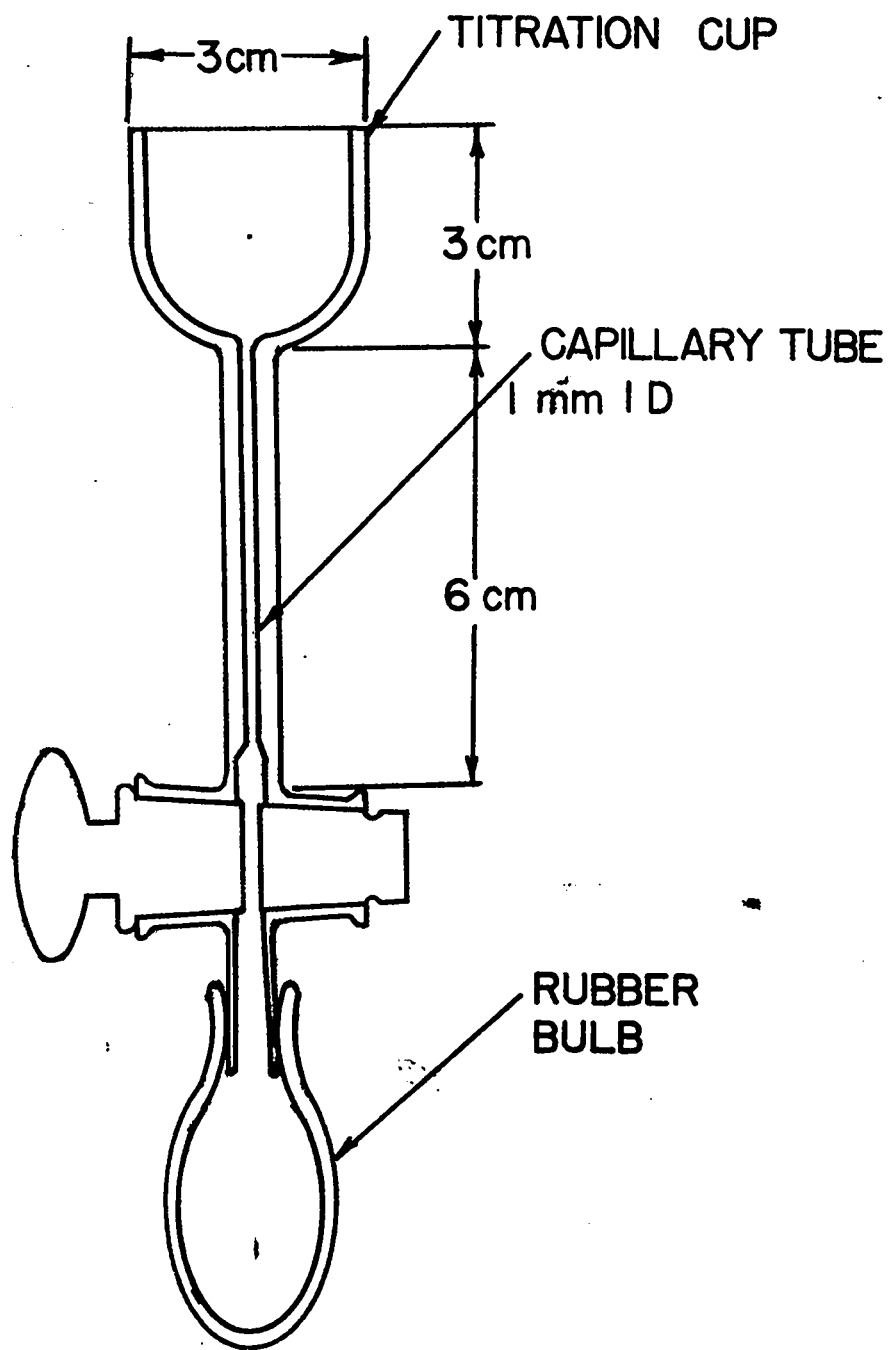

Figure 39¹
Titration Cup



bottle. (24)

- (e) Electric stirrer with glass agitator.
- (f) Microliter pipets, 20 μ l capacity.
- (g) Platinum crucibles, 10 milliliters.
- (h) Infra-red lamp.

(6) Procedure

- (a) In absence of nitrate:

Fill the CO₂ generator with dry ice and bubble the gas stream through the wash bottle for 2 - 3 hours to sweep out the oxygen from the generator and from the water in the wash bottle. Clean the titration cup with cleaning solution and rinse thoroughly. Place the titration cup on the stand and adjust the CO₂ lead so that a fairly rapid stream of CO₂ will impinge on the surface of the solution to be placed in the cup.

Fill the rubber bulb completely with deaerated water and attach it to the cup with the stopcock open. Carefully compress the bulb so that the water is forced into the stem of the cup and displaces all of the air in the stem. Close the stopcock so that the deaerated water fills the stem.

Run into the cup 1 - 2 milliliters of the zinc amalgam and then pipet into the cup the nitrate-free solution to be titrated. The volume of the solution should not be more

(24)

A Dewar flask fitted with a tight-fitting rubber stopper with an outlet to cup and wash bottle through a T; also a safety valve to relieve excess pressure. Fill the flask with dry ice and stopper. Allow a few hours to sweep out air before using.

than 5- 6 milliliters. Adjust the stirrer so that both the amalgam and the solution are agitated. Keep the CO_2 stream running at all times during the determination.

If the solution is neutral or basic add sufficient 2 N H_2SO_4 (usually 2 - 3 drops) to make the solution approximately 0.05 N. If the solution is more acid than this see below.

Reduce for 5 minutes. After reduction add dropwise sufficient 0.1 N KMnO_4 (1 drop is usually sufficient) to make the solution pink and reduce again for 10 minutes after the disappearance of the pink color. If during this second reduction, the solution becomes turbid due to the formation of MnO_2 , add another drop of the 2 N H_2SO_4 and allow sufficient time to reduce the MnO_2 . If the turbidity does not disappear, add another drop of acid.

Following the 10 minute reduction period, stop the stirrer and add 2 - 3 milliliters of CCl_4 . Carefully open the stopcock and squeeze the bulb gently to force water around the amalgam and the CCl_4 layer, in this way washing the amalgam. Release the pressure on the bulb and allow the amalgam to run down into the bulb. Repeat this operation until all of the amalgam is in the bulb and the CCl_4 is drawn into the capillary. At this point there will be a layer of CCl_4 in the bottom of the cup and the reduced solution above. Raise the stirrer so that it will not agitate the CCl_4 layer too violently and wash the stirrer with 1 milliliter of deaerated water. Add exactly 20 microliters of the orthophenanthroline indicator and be sure to wash out the microliter

pipet because these pipets are usually calibrated "to contain".

During the second reduction period, fill the microweight buret with standard ceric sulfate and weigh. After adding the indicator, start the stirrer and titrate to a sharp change from red to colorless (or very light blue). Add the ceric solution slowly near the end point using very small increments. The end point under proper conditions of acidity is sharp; the color change is stable for 5 minutes. Reweigh the buret; the difference is the weight of ceric sulfate solution used in the titration.

(b) In presence of nitrate

Nitrate interferes seriously in the procedure. Even small amounts of nitrate will produce fading and irregular end points.

To remove nitrates before titrating, transfer the solution to a 10 milliliter platinum crucible and carefully add (down the side) 2 drops of concentrated H_2SO_4 . Heat the solution under an infra-red lamp until the fumes of H_2SO_4 are evident. Transfer the crucible to a small hot plate and continue heating until all of the acid has been fumed off. Be careful to avoid spattering and do not ignite the residue. Take up the UO_2SO_4 in 1 - 2 milliliters of water and transfer quantitatively to the titration cup. Do not use more than 3 - 4 milliliters for the transfer. This is necessary because the final volume should not be over 5 - 6 milliliters.

(c) In presence of excess acid

If the acid concentration of the solution to be

164

titrated is greater than 0.05 N, the end point will fade and be indeterminate. If this is the case, or if the acid is other than sulfuric, treat the solution as described in the preceding paragraph.

(d) In presence of organic matter

Organic matter must also be removed. Place the sample in a 10 milliliter platinum crucible and add 2 milliliters of concentrated HNO_3 . Heat gently until the oxides of nitrogen cease to evolve, and add 3 drops of concentrated HClO_4 . Heat the solution gently until the solution becomes colorless. Add more HClO_4 if necessary. After the solution becomes clear, proceed as above.

(e) For U_3O_8

Dissolve the oxide in HNO_3 and proceed as above.

(7) Indicator Blank

An appreciable amount of ceric ion is required to change the indicator and this blank must be known accurately; the quantity of indicator must be measured precisely. To do this care must be exercised in pipetting the small volume (20 λ) of indicator. The indicator blank is determined by carrying out the complete procedure in the absence of uranium. Under the specified conditions, however, the blank which is equivalent to approximately 50 γ of U need be determined only once for the same batch of indicator.

(8) Theoretical

Zinc amalgam will reduce the +6 uranium only to the +4 state. (Jones reductor, however, will produce a mixture

of +3 and +4.)



Permanganate is used after the first reduction step because it effectively eliminates a positive error, the exact source of which is undetermined.

(9) Precautions

- (a) A sufficiently rapid stream of pure CO_2 must be blown into the cup during all operations.
- (b) All air must be removed from the stem of the cup before introducing the amalgam.
- (c) The cup must be clean so that no mercury will stick to the sides.
- (d) Acidity of the solution must be approximately 0.05 N.
- (e) The indicator must be added quantitatively.
- (f) The end point is sharp and the increments near the end point must be small so as not to over-run the end point.
- (g) All nitrate and organic matter must be removed.

(10) Calculation of Results

Let N be the milliequivalents of ceric ion per gram of solution; then

$$\text{mg. U} = 119.09 \cdot N \cdot (x-b)$$

where x is the grams of ceric sulfate solution used in the titration and b is the grams of ceric sulfate solution used for the indicator blank.

(11) Reference

LAMS-176
LAMS-462 (Terminal Report)

8.6-5 Microdetermination of Azide Nitrogen by a Kjeldahl Procedure

(1) Abstract

When an azide is treated with a reducing agent in sulfuric acid medium and then carried through a Kjeldahl digestion and distillation, one third of the azide nitrogen is recovered. The remainder is liberated as nitrogen gas.

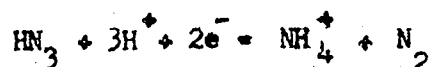

The reaction is quantitative and forms a satisfactory basis for a procedure for the determination of azide nitrogen.

(2) Procedure

See LA 237.

8.7 GRAVIMETRIC PROCEDURES8.7-1 Gravimetric Determination of Molybdenum in Molybdenum-Uranium Alloys

(1) Abstract

The molybdenum after oxidation with nitric acid is precipitated, filtered, ignited, and weighed as lead molybdate. Precipitation of uranium is prevented by buffering the solution with ammonium acetate.

(2) Applicability

The method has been used successfully for molybdenum-uranium alloys with molybdenum content varying between 0.5 and 50 per cent.

(3) References

Furman, N.H., "Scott's Standard Method of Chemical Analysis", 5th ed., I, pp. 589-590, New York, D. Van Nostrand Co., 1939

Hillebrand, W.F., and Luncell, G.E.F., "Applied Inorganic Analysis", pp. 253-254, New York, John Wiley and Sons, 1929.

Project Report IA-416.

8.7-2 Micro Determination of Gallium In Plutonium-Gallium Alloys

(1) Abstract

Gallium is separated from a hydrochloric acid-plutonium chloride solution by extraction of chlorogallic acid with isopropyl ether. The gallium is re-extracted from the ether by shaking with water and is determined gravimetrically as the 8-hydroxyquinolate, $\text{Ga}(\text{C}_9\text{H}_6\text{ON})_3$.

(2) Applicability

The method has been used in analyzing plutonium-gallium alloys with a gallium content ranging from 0.5 to 2.0 weight per cent.

(3) Size of Sample

Sufficient sample is taken to give approximately 1 milligram of gallium.

(4) Accuracy

In the analysis of control samples (pure plutonium solutions to which known amounts of gallium were added) the maximum observed deviation from the true value was 3 per cent, the average deviation 1 per cent.

(5) Reagents

- (a) Isopropyl ether. Shake with alkaline permanganate and re-distill.
- (b) Mercury, c.p.
- (c) HCl, 12N, standardized.
- (d) Sodium acetate solution, 20 per cent.
- (e) Alcoholic 8-hydroxyquinoline solution, 5 per cent.
- (f) Phenolphthalein indicator.
- (g) Ammonium hydroxide, conc.

(6) Apparatus

- (a) Shaking tubes. Heavy wall, pyrex test tube, 1 1/4 centimeter outer diameter, 14 centimeters long, with well fitted ground glass stopper.
- (b) Pipet, 1 milliliter, graduated in hundredths.
- (c) Transfer pipets, syringe type, 5 milliliter capacity, 20 centimeters long.
- (d) Steam bath.
- (e) Buret, 1 milliliter.
- (f) Shaking machine.
- (g) Electric oven.
- (h) Beakers, 30 milliliters.
- (i) Rubber policeman .
- (j) Munroe crucibles, 10 milliliters, and filtering apparatus.
- (k) Semi-micro balance (Seke).

(7) Procedure

Heed Health and Safety Rules Outlined in Section 8.2

(a) Preparation of sample and extraction:

1. Cut metal specimens each approximately 100 milligrams in weight and weigh each sample accurately to 0.2 milligrams.
2. Calculate the volume of 12 N HCl needed to dissolve the Pu, ⁽²⁵⁾

(25)

In order that quantitative results may be obtained in the extraction procedure, the acidity must be adjusted to 7.3 N. At this normality the distribution ratio of gallium between isopropyl ether and water is a maximum.

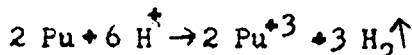

The equivalent weight of Pu is $239/3 = 79.7$. If W is the weight of the sample in mg. and N is the actual normality of the HCl, the volume (in ml.) of acid necessary to dissolve the metal is $W / (79.7) (N)$.

and the volume of additional HCl and H₂O needed to bring the resulting solution to 7.3 N in HCl in a volume of 1.00 milliliters. (26)

3. Pipet the calculated volume of H₂O into the shaking tube and drop in the metal sample. Add the total calculated volume of HCl slowly from the 1 milliliter buret. The reaction will start immediately upon the addition of the first drop of acid. Keep the tube inclined while adding the acid to prevent the possibility of spray emerging from the tube.
4. When the sample is in solution, add 4 drops of mercury to reduce the iron present (27) and stopper the tube with a well-greased ground glass stopper. Place the tube in the shaking machine and shake for 5 minutes.
5. Remove the tube from the machine and add 1 milliliter of isopropyl ether, being careful to wash down the stopper with the first portion added. Regrease the stopper if necessary and shake for 20 minutes.

(26)

The volume of N-normal HCl required to make 1 milliliter of 7.3 N HCl is $7.3/N$ ml. The total acid requirement is

$$V_a = \left[\frac{W}{(79.7)(N)} + \frac{7.3}{N} \right] \text{ ml.}$$

and the water required is $V_w = (1.00 - V_a)$ ml.

It is evident that a number of approximations have been made in these calculations. For example, the volume change that accompanies the dissolving of the metal is neglected, the volumes of water and 12 N acid are assumed to be additive, and the sample is assumed to be 100 per cent Pu (no correction being made for the gallium present).

(27)

FeCl₂ will not be extracted by isopropyl ether.

6. After shaking, allow the Pu-Hg layer to separate from the ether and swirl the tube gently so that a sharp separation takes place. Transfer the ether layer to a second shaking tube by means of the transfer pipet. Wash the pipet by drawing up an equal volume of ether and add the ether washings to the second tube. The same pipet should be used for any given sample through all the subsequent operations.
7. Add 1 milliliter of isopropyl ether to the first tube, stopper (greasing stopper if necessary), and shake for another 20 minute interval.
8. Transfer the ether layer to the second tube. Add a small quantity of ether to the first tube, invert several times to wash the sides of the tube and transfer the ether layer to the second shaking tube. The material in the first tube must be reserved for plutonium recovery.
9. Still using the same pipet add 5 milliliters of water to the second tube.
10. Add a glass bead to the second tube, stopper with a well-greased stopper and shake for 10 minutes.
11. Transfer the lower aqueous layer by means of the pipet to a 30 milliliter beaker containing 5 milliliters of 20 per cent sodium acetate, 1 drop of phenolphthalein, and 1 drop of ammonium hydroxide. While the pipet is passing through the upper ether layer, expel air through the pipet so that no ether is permitted to enter. Fill the pipet with water and add these washings to the beaker.
12. Repeat the re-extraction procedure with another 5 milliliters of water.
13. Transfer the water layer to the beaker and add a small quantity of water to the shaking tube, stopper, invert a few times, and transfer this aqueous layer to the beaker. The total volume in the beaker should now be between 15 and 20 milliliters.

171

(b) Precipitation

Cover the beaker with a watch glass and heat below the boiling point until most of the color of the indicator has disappeared. Wash down the cover glass and add, dropwise, 15 drops of the alcoholic 8-hydroxyquinoline solution, waiting between drops for the yellow precipitate to form. Place on the steam bath and digest for an hour.

(c) Transferring, Washing and Drying of the Precipitate.

1. Transfer the precipitate to a tared ⁽²⁸⁾10 milliliter platinum Munroe crucible using hot water to wash out the precipitate. Transfer as much as possible by washing before using a policeman. Extreme care must be taken in the transfer since the precipitate is difficult to handle because of its tendency to crawl and become finely dispersed.
2. Wash the precipitate in the Munroe crucible 3 times with hot water. Inspect the beaker with a magnifying glass to see that all the precipitate has been transferred.
3. Dry in an electric oven at 120° C for one hour. Cool for one hour in the balance room and weigh ⁽²⁸⁾as

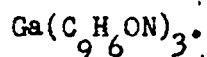

⁽²⁸⁾

Weighings to the nearest 0.005 milligrams are made on the semi micro balance.

(8) Precautions

- (a) The acidity of the HCl solution must be accurately adjusted before extraction.
- (b) The transfer of the precipitate is difficult and care must be used. Use plenty of hot water for the operation.

(9) Calculations

mg. Ga = mg. precipitate x 0.1389

per cent Ga = $\frac{\text{mg. Ga}}{\text{sample wt. in mg.}} \times 100$

(10) References

LAMS-266

LAMS-276

LAMS-288

LA-425 (Terminal Report)

8.7-3 Gravimetric Determination of Carbon in Uranium Tetrafluoride

(1) Abstract

The sample, intimately mixed with MgO, is burned at 1000° C in a stream of oxygen. Fluorine not retained by the MgO is trapped by PbO₂. The carbon dioxide formed by oxidation of carbon in the sample is quantitatively absorbed on Ascarite and weighed.

(2) Applicability

The method has been used only for uranium tetrafluoride, but it is expected that it would give equally satisfactory results with certain other halogen-bearing inorganic materials.

(3) Procedure

See LA-416.

8.7-4 The Determination of Carbon and Hydrogen in Calcium Metal

(1) Abstract

The sample is burned at 1000° C in oxygen diluted with helium and the carbon dioxide and water formed by the oxidation of carbon and hydrogen compounds in the sample are quantitatively absorbed on Ascarite and Dehydrite and weighed. Calcium burns at an uncontrollably fast rate in pure oxygen or in air; by properly diluting the oxygen with the inert gas, helium, the rate of combustion can be easily controlled.

(2) Applicability

The method has been used only for calcium metal but it is expected that it would give equally satisfactory results with magnesium and other active metals which are difficult to handle by the conventional procedure.

(3) Method of Sampling

The sample should be in the form of small pieces about 2 -- 3 millimeters across or in thin strips or turnings. Thick pieces are difficult to oxidize completely because of the formation of a protective oxide layer. Exposure of the sample to air should be kept at a minimum to prevent reaction with carbon dioxide and moisture.

(4) Procedure

See LA-416A.

8.7-5 Electrolytic Determination of Cobalt in Tungsten Carbide-Cobalt Alloys

(1) Abstract

The alloy is dissolved in a mixture of hydrofluoric acid

and nitric acid. The volatile acids are removed by fuming with sulfuric acid and the residue is dissolved in ammonium hydroxide. Ammonium chloride and sodium bisulfite are added to the solution which is cooled to 10° C and electrolyzed for 45 minutes using a rotating cathode.

(2) Range of Applicability, Size of Sample, Accuracy

The method has been used with satisfactory results in the analysis of alloys containing from 1 per cent to 9 per cent cobalt. The weight of sample taken should be sufficient to furnish 60 to 80 milligrams of cobalt. When more than 90 milligrams of cobalt is electrolyzed low results are obtained.

The spent electrolyte contains a small amount of cobalt. Except in the most accurate work, however, this amount of undeposited cobalt as well as the small amount of extraneous material (sulfur and tungsten) deposited on the cathode can be neglected since the two quantities are approximately equal.

(3) Procedure

See LA-416A.

8.8 GASOMETRIC PROCEDURES

8.8-1 Microcarbiding Method for Determination of Oxygen

(1) Abstract

The oxygen content of small samples of metal can be determined by carbiding the metal in vacuo and analyzing the gases evolved.

(2) Applicability

The method was designed for the determination of oxygen in uranium and plutonium metals and has been used chiefly for this purpose. Plutonium chlorides, plutonium fluorides, plutonium oxide, uranium tetrafluoride, uranium oxides, thorium nitride, thorium oxide, zirconium nitride, tungsten carbide and platinum metal have also been analyzed for oxygen by this procedure.

(3) Size of Sample and Limit of Sensitivity

If high sensitivity is not required, a practical working limit is 100 ppm on a 50 milligram sample. The ultimate limit of sensitivity which can be achieved is approximately 5 ppm on a 50 milligram sample.

(4) Apparatus

The apparatus used for the determination of oxygen consists of two parts. One is the high vacuum system in which the conversion of the oxygen in the sample to carbon monoxide takes place. The other is the micro gas analysis apparatus of the type described by Prescott (loc. cit.).

The arrangement of the high vacuum system to which the furnace tube is attached is shown in Figure 40. The pumping system consists of a Welch two stage rotary oil pump. This is used to back a medium sized Brewer mercury diffusion pump (Figure 40). This in turn is used to back the main pump, an extra large Brewer pump (2, Figure 40).

Figure 40
High Vacuum System

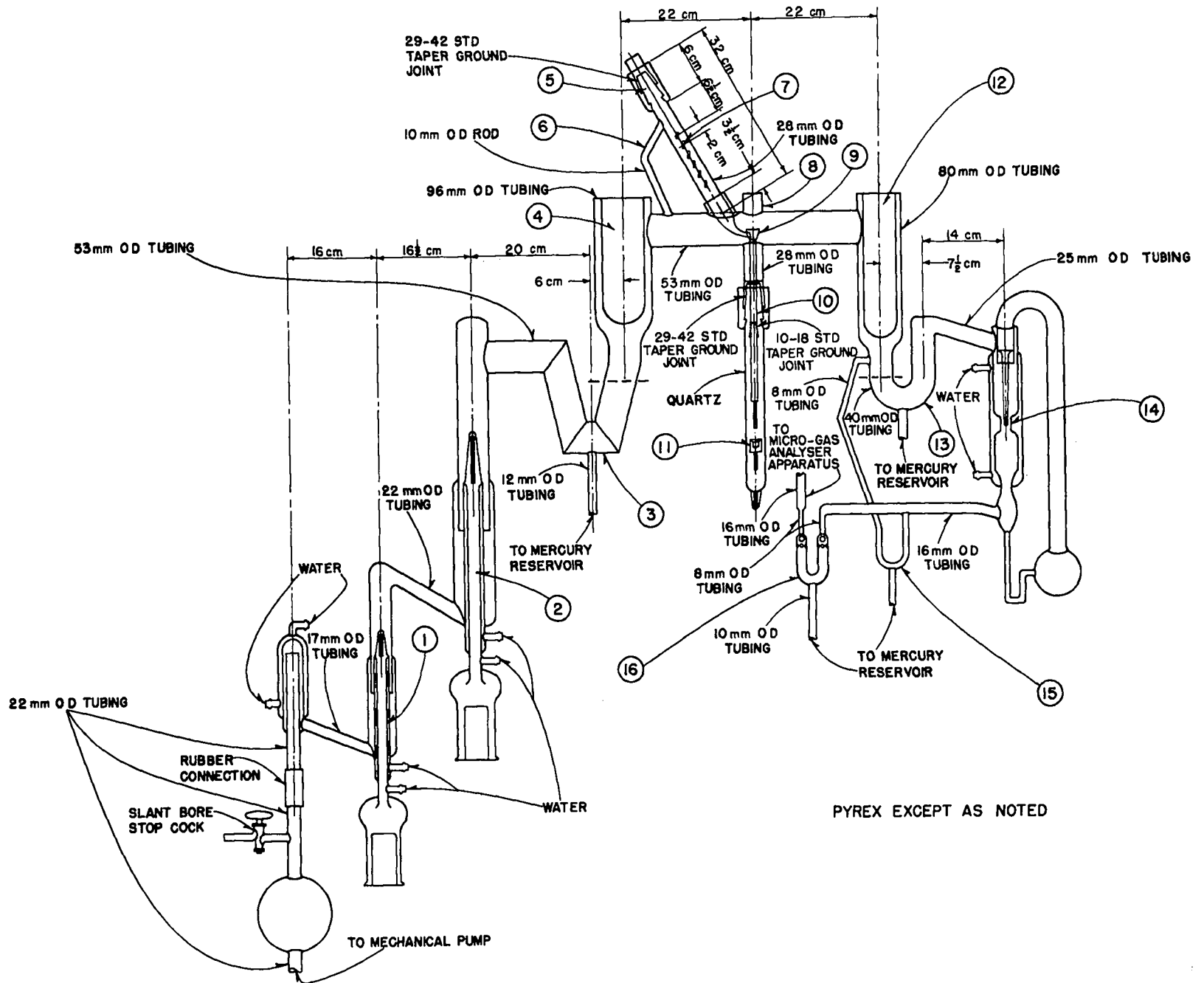

The vacuum line is connected to the large diffusion pump through a mercury cutoff (3, Figure 40). This cutoff serves to isolate the pumps from the line after degassing has been completed (see below).

The central part of the line consists of the quartz reaction vessel joined to the vacuum line by a quartz-pyrex standard taper mercury sealed joint (10, Figure 40), graphite crucible, and multiple loading manifold. These will be described in detail.

The end of the vacuum line away from the main pumping system leads through a mercury cutoff (13, Figure 40) to the high vacuum end of a two stage mercury diffusion pump (14, Figure 40). This is used to collect the gases evolved by the sample. The fore vacuum end of the collection pump is connected to the gas analysis apparatus through a cutoff (16, Figure 40) made with two glass check valves. By using this type of connection it is possible to "break" either high vacuum or gas analysis system to atmospheric pressure independently.

At times it is convenient to allow the gas from the collection pump to be pumped out through the main manifold of the high vacuum system. This is accomplished by means of a bypass system (15, Figure 40).

Interposed between the two mercury cutoffs and the quartz reaction vessel are two dry ice-ethylene trichloride traps shown at 4 and 12 in Figure 40. These traps prevent the electrodeless discharge of mercury vapor present in the high vacuum system.

The loading system which is an integral part of the vacuum line allows six samples to be held in vacuum at one time. The quartz vessel is shown in Figure 41.

The top of the multiple loading system is closed by a mercury sealed cap (5 Figure 40). A glass rod support (6, Figure 40) is considered necessary to bear the weight of the mercury in this type of seal. The buckets (7, Figure 40) into which the samples are loaded are pivoted on fixed 40 mil tungsten wires. Below the pivot point is a compartment containing a sealed-in piece of iron. The individual buckets are spaced far enough apart so that, starting at the top, the buckets may be individually turned up by a magnet held above the loading manifold. The spout of the loading manifold extends about 10 millimeters below the top of a vertical funnel (9, Figure 40) to prevent the samples from bouncing into the main manifold. Directly above the vertical funnel is placed a plane glass window (8, Figure 40) through which the temperature of the crucible is read by means of a mirror arrangement and pyrometer. This plane glass window is connected to the vacuum line by a mercury sealed joint, (not shown in the figure), an arrangement which makes it possible to remove the window for cleaning. The upper section of the funnel is sealed permanently into the pyrex system, while the lower section, made of quartz (Figure 42) is removable for cleaning. The quartz section, which carries a male joint and connects to a female joint on the pyrex section, is supported by molybdenum wire hooks. A one-half inch

Figure 41
Quartz Reaction Vessel

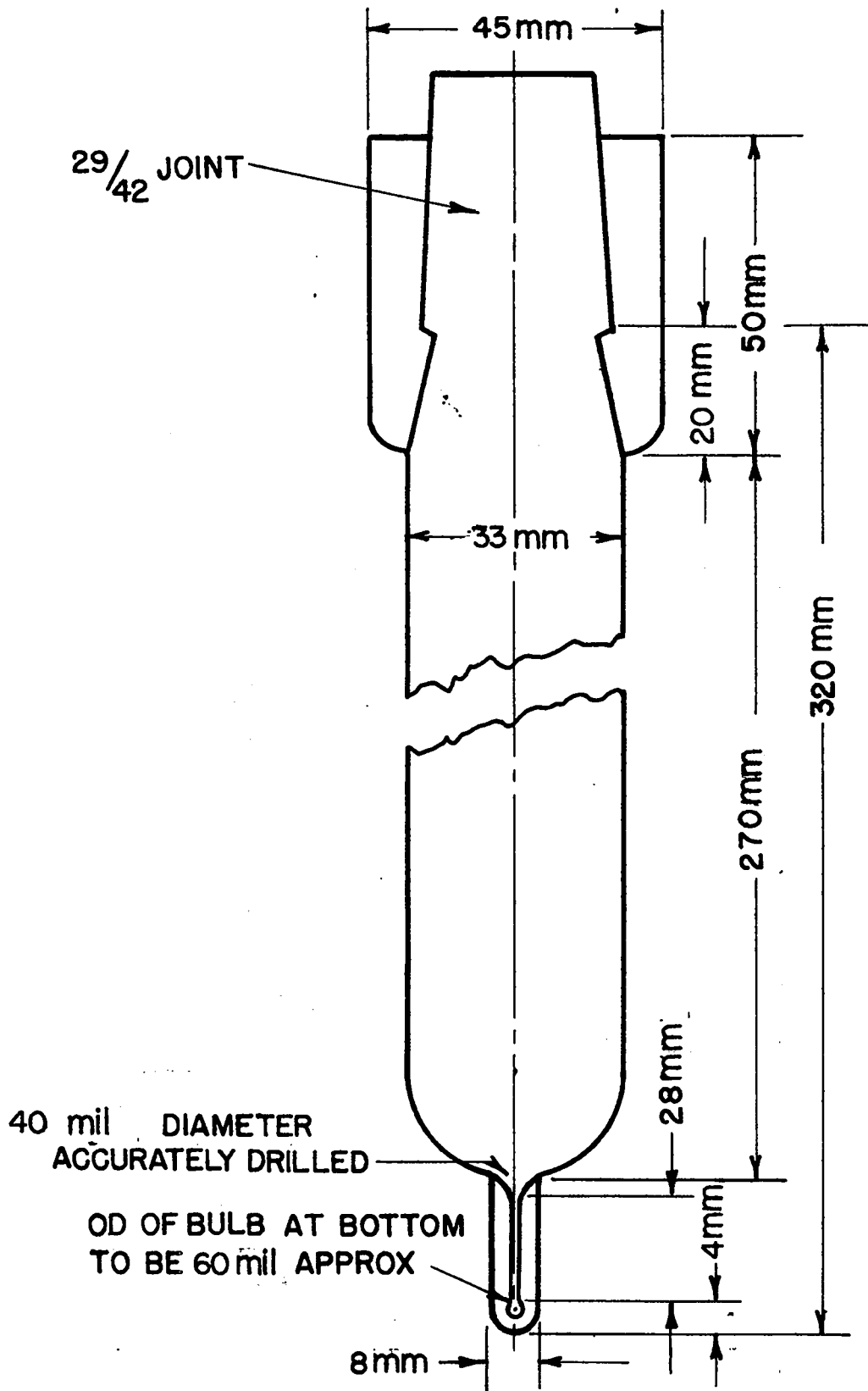

Figure 42
Quartz Dropping Tube

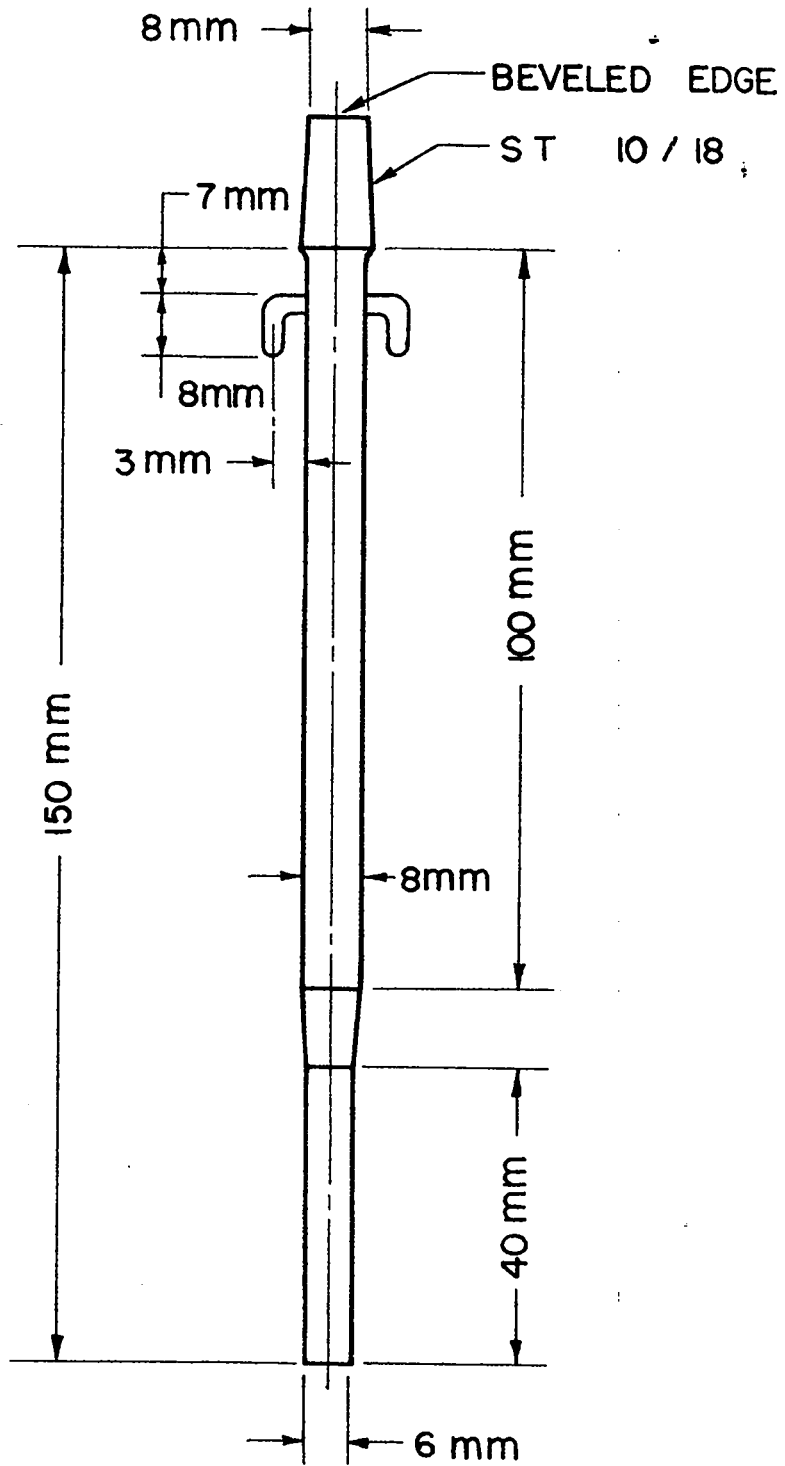

Figure 43
Graphite Crucible,

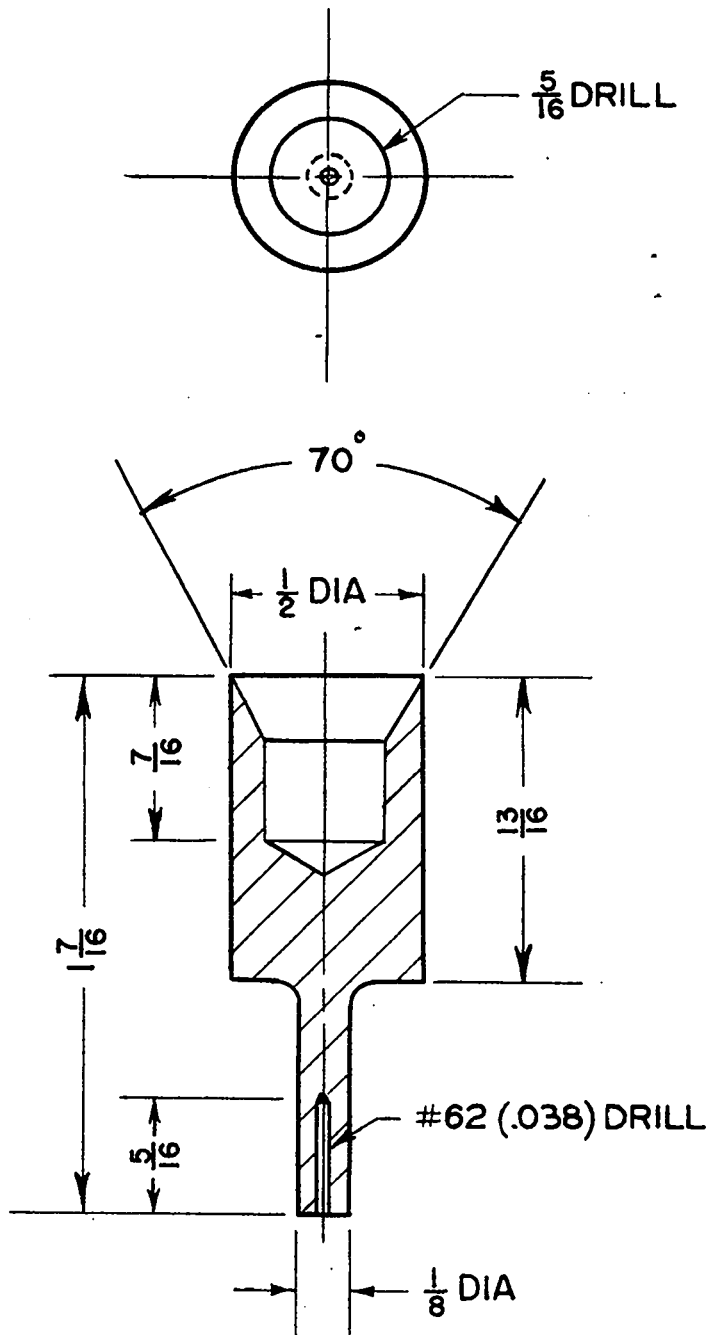

Figure 44
Circuit for Solinoid Valve Control

R1 0.1 MEG. 1 WATT
 R2 2.0 MEG. 1 WATT
 R3 2.0 MEG. 1 WATT
 R4 5,000 W 2 WATT
 R5 10,000 1 WATT
 R6 150W 25 WATT
 R7 10,000W 1 WATT
 R8 5,000W V.D. 10 WATT
 R9 250W 2 WATT

C1 0.006 MF 400V. PAPER
 C2 50 MF 50V. ELECT.
 C3 50 MF 300V. ELECT.
 C4 50 MF 300V. ELECT.
 C5 50MF 300V. ELECT.
 C6 8MF 450V. ELECT.
 C7 50MF 150V. ELECT.
 VT-1 RCA 2051
 VT-2 6J5 GT
 VT-3 WL 632

UT-4 6X5
 TS-1,2,3,4, AMPH PC 3F
 TS-5 JONES BLOCK 2 TERM
 TS-6 AMPH PWR. MALE
 T-1 STANCOR P-6160 110V-110V
 T-2 STANCOR P-6135 110V-5V
 T-3 T-19DOI (1:1) PRI-1/2 SEZ
 T-4 STANCOR P-3064 110V-6V

SW-1 3POLE 3POS. SELECT. ISOLANTITE
 SW-2 DPST 1AMP 110V. TOGGLE
 SW-3 DPST 1AMP 110V. TOGGLE
 SW-4 DPST 1AMP 110V. TOGGLE
 SW-5 DPST 1AMP 110V. TOGGLE
 SW-6 DPST 1AMP 110V. TOGGLE
 SW-7 SPST, NORM OPEN, P. B. SPRING RETURN.
 L1 STEP RELAY (SPECIAL)
 L2 ADVANCE RELAY*964-B
 L3 ADVANCE RELAY*904-A
 L4 ADVANCE RELAY*305-B
 P1 RED 6V PILOT LAMP
 P2 GREEN 6V PILOT LAMP
 P3 AMBER 6V PILOT LAMP
 FZA, 110V FUSE
 C0 TELEPHONE WHEEL COUNTER 20V.

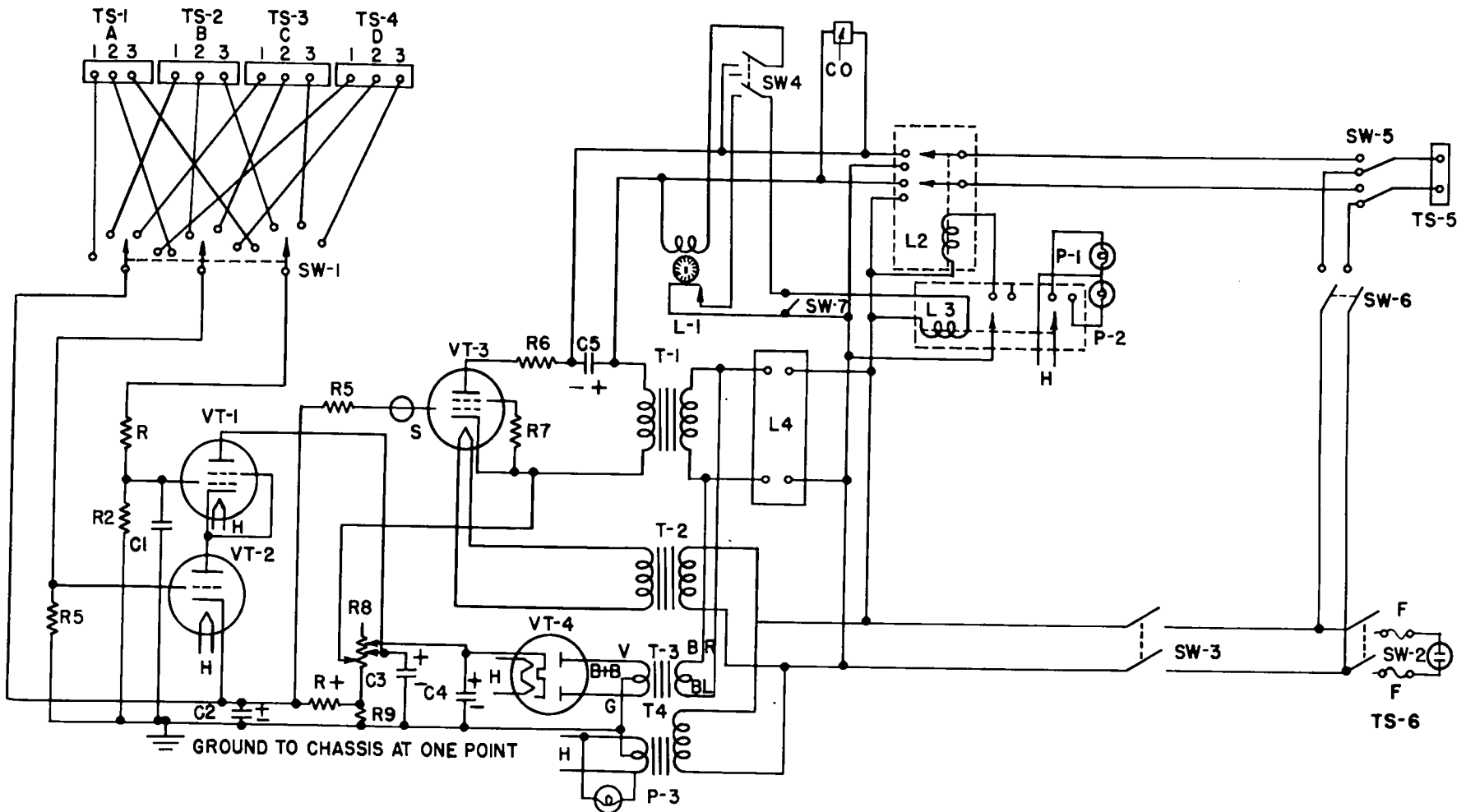

APPROVED FOR PUBLIC RELEASE

APPROVED FOR PUBLIC RELEASE

Figure 45
Micro Diffusion Pump

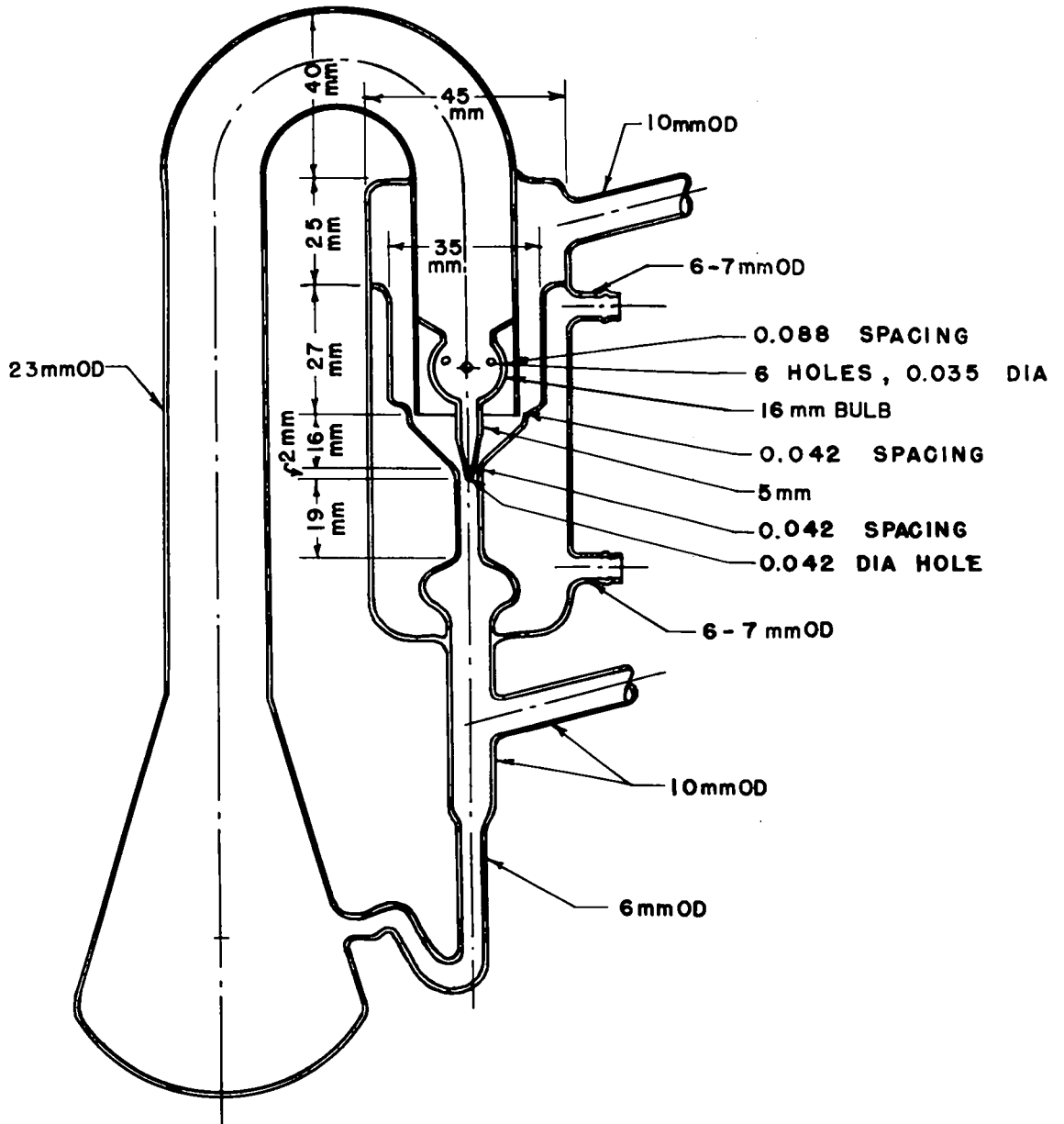

diameter spectroscopic graphite crucible (11, Figure 40) is supported 15 to 20 millimeters below the bottom of the funnel by a 40 mil tungsten wire. The dimensions of the crucible are given in Figure 43.

For a more complete description and drawings of the equipment refer to Reports LA 58 and LA 153.

The micro gas analysis apparatus has been modified in several respects. The insertion of a short section of capillary into one of the vertical tubes of the Toepler pumps prevents mercury hammer and eliminates breakage of the pumps. In place of the solenoid valve recommended by Prescott for operating Toepler pumps we have substituted a simpler valve (General Electric Co. type CR 9507-CIB solenoid valve). The circuit used for operating this valve is shown in detail in Figure 44. It can be set to make the Toepler pump take a pre-determined number of strokes. A reagent tube containing copper at 350° has been added to remove oxygen from the gas mixture collected. A 10 cubic centimeter calibrated pipet has been added so that larger gas volumes can be collected. A much more satisfactory micro-diffusion pump (Figure 45) has replaced the type used by Prescott.

(5) Operation

Metal samples should weigh approximately 50 milligrams. Uranium samples are cleaned by immersion in 1:1 nitric acid until bright, followed by washing with water, absolute alcohol, and octane in rapid succession. Plutonium samples

are electrolytically polished ⁽²⁹⁾ and immersed in octane until loading.

(29)

See Section 8.2.

When the crucible and quartz vessel are in place and the loading manifold is capped, the system is evacuated by means of the mechanical pump. The vacuum is broken by turning off the mechanical pump and admitting helium into the system through a stopcock (not shown in the figure) in the line between the mechanical pump and the first mercury diffusion pump. When sufficient helium to give a pressure of a few millimeters of mercury has entered the system the cap is removed from the loading manifold. A slow stream of helium is allowed to escape through this opening until the six samples are loaded. The cap is then replaced.

Once the line is evacuated and the diffusion pumps are in operation, the graphite crucible is heated to about 1400° C by means of a 10 Kw output oscillator. The reaction tube is cooled by running hot water. The crucible is heated for about ten minutes and then the entire line with the exception of the diffusion pumps, loading manifold and reaction vessel is flamed with an air-gas flame. The vacuum line is allowed to cool and the traps are filled with refrigerant. At this time the temperature of the crucible is increased to 2000° C. Outgassing is continued for several hours and then blanks are taken at one-half hour intervals until the blank corresponds to about 2 ppm on a 50 milligram sample (gas volume of about 0.15 mm³) at which point outgassing is considered satisfactory.

In order to determine the blank of the system the pressure cutoff (16, Figure 40) between the high vacuum and analysis systems is opened, the bypass cutoff (15, Figure 40) is closed, the cutoff (13, Figure 40) leading to the collection pump (14, Figure 40) is opened, the cutoff (3, Figure 40) leading to the outgassing pumps (1 and 2, Figure 40) is closed, and collection into the micro-pipet in the analysis system is begun. The ordinary collection period of ten cycles of the Toepler pump in the analysis system is approximately three minutes.

When the blank is satisfactory the induction heater is turned off and the crucible is allowed to cool 15 minutes. Then the line is set for collection of the gas in the micro-pipet (see preceding paragraph) and the first sample (top bucket) is dumped into the cold crucible.

Heat is turned on at a crucible temperature of about 1000°C and the evolved gas is collected almost continuously until the rate of collection per ten cycles of the Toepler pump is less than ten per cent of the total volume already collected. The temperature is raised by 100 to 200° stages and the gas collected as above until 2000° C is reached. At 2000° C gas is collected almost continuously until the volume collected in ten cycles of the Toepler pump is constant at less than twice the blank. The point at which the collection is stopped varies somewhat according to the total volume collected and current operating conditions.

Once collection has been stopped the system is rearranged so that the outgassing pumps are put into use. After one-

half hour of outgassing at 2000° C a check is made of the blank of the system and if the blank is satisfactory the next sample is run according to the above procedure. This may be repeated until all samples are dumped or until it is necessary to stop for analysis of the gases collected.

The procedure for analyzing the gases collected from the metal samples is adequately outlined by Prescott (loc. cit.). The reagents are used in the following order: (a) magnesium perchlorate for water, (b) soda lime for carbon dioxide, (c) copper at 350° C for oxygen, (d) copper oxide at 350° C in series with magnesium perchlorate for hydrogen and (e) copper oxide at 350° C in series with soda lime for carbon monoxide.

Gas collected from uranium samples is not analyzed except for special cases. A gas composition equivalent to 90 per cent carbon monoxide is assumed and oxygen values are reported on the basis of this composition. In analyzing plutonium samples it has not been necessary to determine oxygen in amounts below 100 ppm. Hence if the total volume of gas collected from the sample is less than the volume of carbon monoxide which could be produced by a sample containing 100 ppm of oxygen the oxygen content of the sample is reported < 100 ppm. If the gas volume is large the gas must be analyzed.

(6) References

Prescott, Ind. Eng. Chem., Anal. Ed., 11, 230 - 233 (1939)

LA-58

LA-153

8.8-2 A Micro Combustion Method for the Determination of Carbon

(1) Abstract

The sample is burned in oxygen at low pressure and the gaseous products of combustion are analyzed in a Prescott gas analysis apparatus. The estimated limit of sensitivity is 20 ppm of carbon on a 50 milligram sample.

(2) Applicability

The method has been applied to uranium and plutonium metals, uranium carbide and plutonium-gallium alloys.

(3) Apparatus

The system is composed of three sections which are separated by special mercury cutoffs. These are (a) a high vacuum section, (b) an oxygen supply section, and (3) a Prescott gas analysis apparatus.

The high vacuum system, where combustion of the sample occurs, is shown in Figure 46.

The loading manifold (Figure 47 shows details) sits in a vertical position and is removable from the vacuum line for loading purposes. In its top is a plane glass window through which the temperature of the crucible below is read. The eight buckets in which the samples are placed are held in blisters on opposite sides of the loading manifold. They are pivoted in such a way that they remain in their normal vertical position by turning as the loading manifold is inverted. The samples are loaded while the manifold is inverted. A mercury sealed pair of 40/50 ground joints makes a vac-tight connection between the loading manifold and the main manifold. When a bucket is turned up, the sample it contains drops

Figure 46
High Vacuum Carbon Combustion System

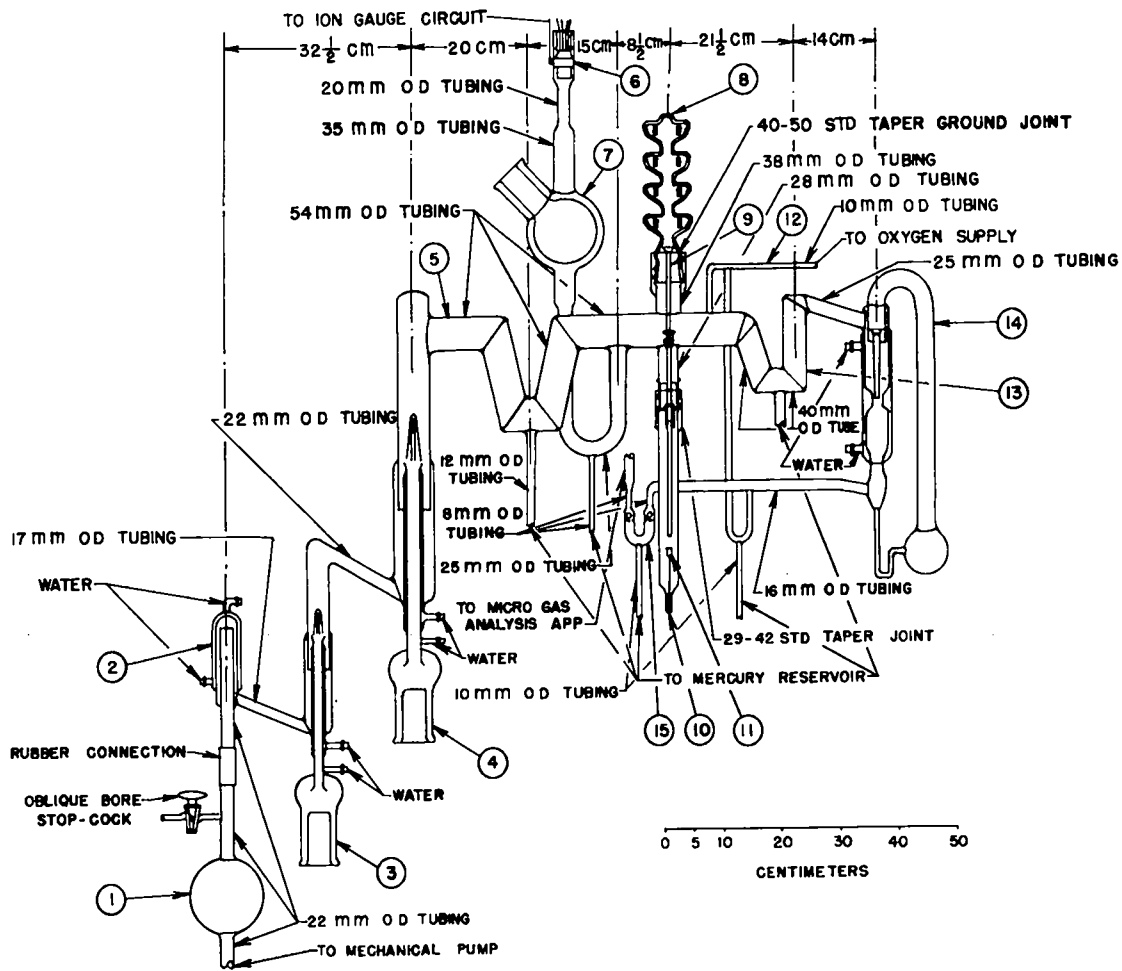
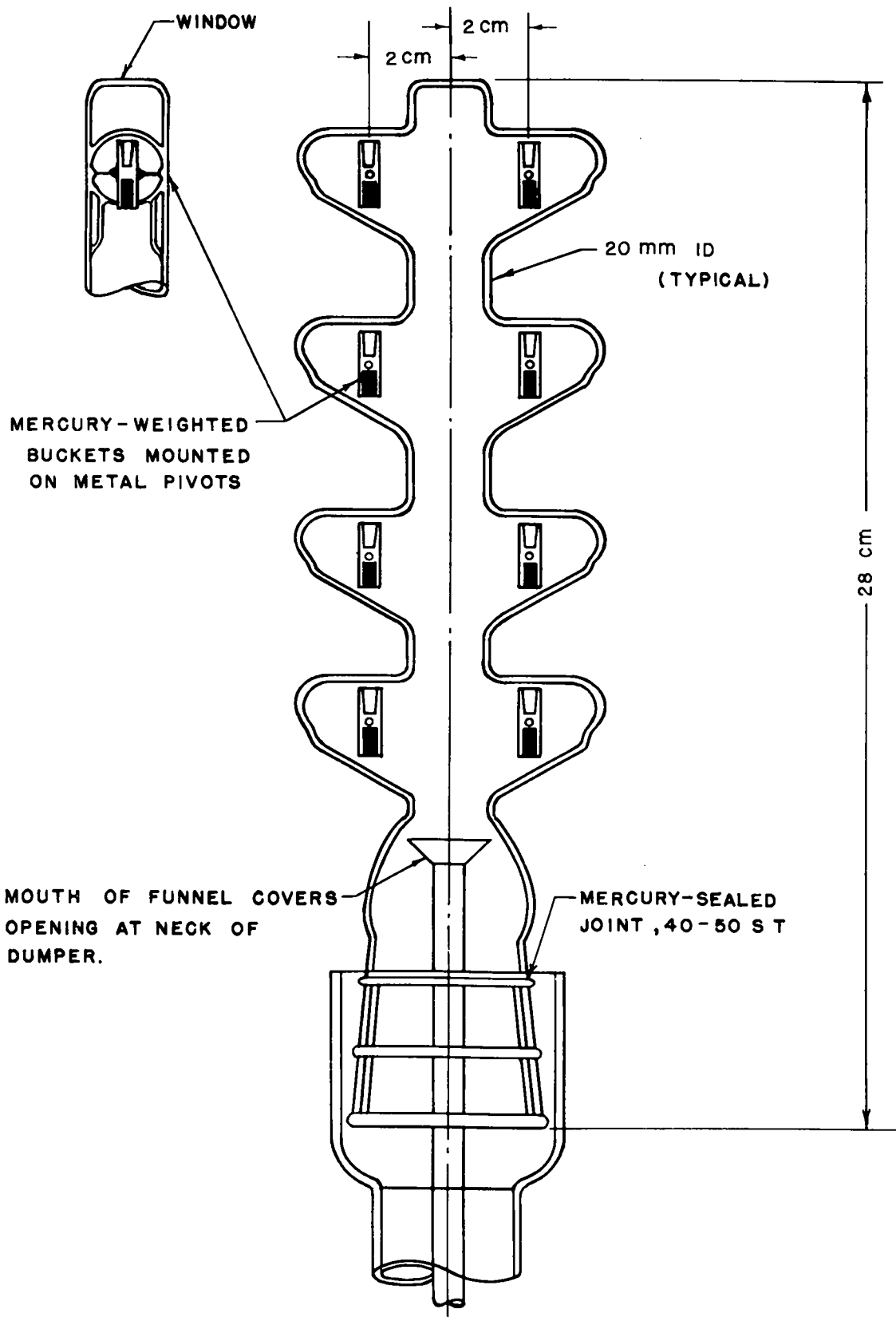

Figure 47

Multiple Loading Manifold.



directly into a funnel below. This funnel is made of three sections. The top is the funnel proper and has a male joint at its bottom so that it may be removed from the mid-section. The latter is sealed permanently into the system by means of supporting rods sealed to the outer glass tubing. It has a female joint at both upper and lower ends. The bottom section is quartz with a male joint at its top. It reaches to within 15-20 millimeters of the crucible.

The crucible is made of platinum low in carbon content. It is fired in an oxygen atmosphere before it is used. No liner is used. This crucible is supported by an 8 centimeter long, 80 mil diameter platinum wire, also low in carbon content. The dimensions and design of the crucible are shown in Figure 48.

The reaction tube, the dimensions of which are shown in Figure 41, is of quartz. (These tubes can now be procured from Hanovia Quartz). The vessel is connected to the pyrex vacuum line by means of mercury sealed ground joints.

The oxygen supply section of the line is shown in Figure 49. It consists of a bulb (10, Figure 49) containing mercuric oxide which may be heated to a temperature of 500°, a condenser for taking out mercury vapor, a Toepler pump (Eck and Krebs, cat. no. 4100) having check valves (5 and 8, Figure 49) to prevent the gas from backing up, a 3 liter storage bulb (4, Figure 49) for oxygen, and a

Figure 48
Platinum Crucible

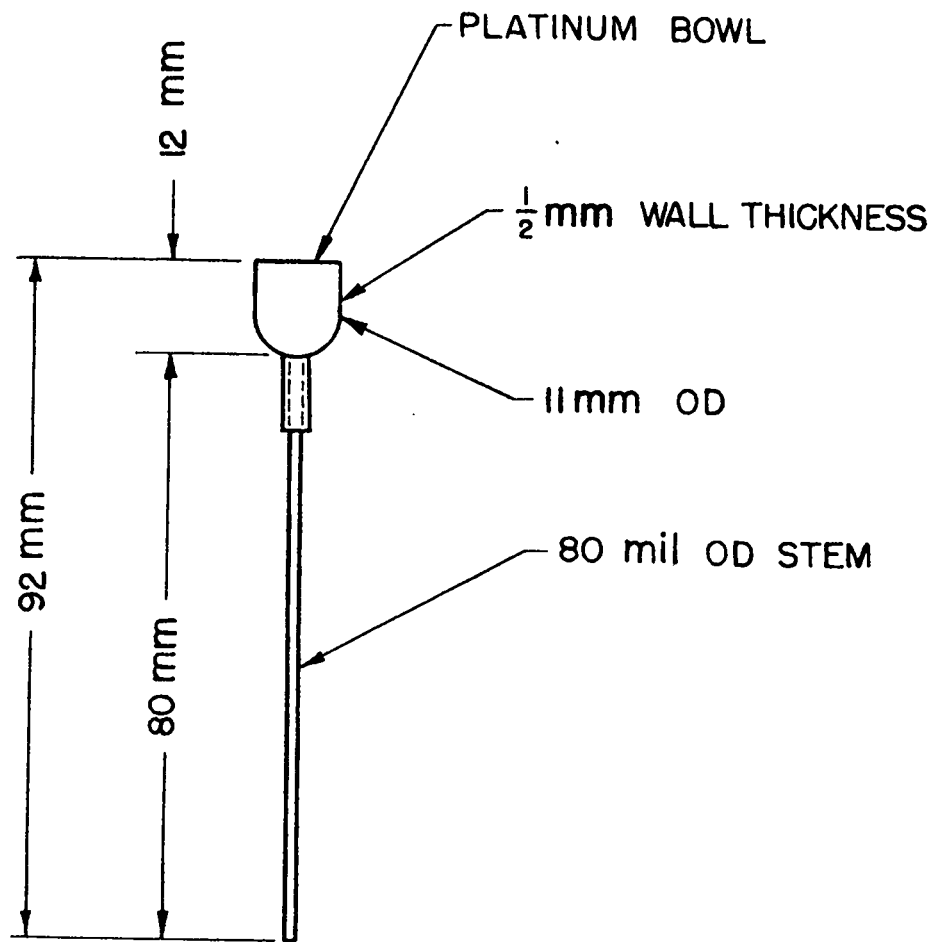

gas measuring buret. Between the storage bulb and the measuring buret is a mercury cutoff (3, Figure 49) which is designed to hold gas pressure on one or both sides while isolating one side from the other. This "valve" consists of two fine grade fritted pyrex plates of 20 millimeters diameter sealed 5 centimeter apart in the horizontal outlet tube of the storage bulb. When the "valve" is closed, mercury fills the space between the two discs. The rate of flow of gas from the high pressure to the low pressure side depends on what fraction of the plates remains covered by mercury when the gas is measured out. The measuring buret is designed to handle up to 15 cubic centimeters of oxygen. A capillary sealed into the buret (Figure 50) prevents throwing mercury when the gas is released from the buret. When the gas in the buret is compressed (by running up mercury in the bulb) the mercury trapped in the capillary is blown out into the tube containing the reference column of mercury. Most of the gas then escapes through the capillary before mercury again covers it. No mercury is thrown when the residual gas is allowed to escape by pulling the mercury below the bottom of the lower outlet.

At the inlet to the Prescott analysis system is placed a quartz combustion tube, joined by graded seals to the pyrex system. This tube contains about 60 grams of copper metal encased in platinum foil. During operation, the copper is heated to 700°C . at which temperature it takes out oxygen but allows the gases with which we are concerned to

Figure 49

Oxygen Supply for High Vacuum Carbon Combustion

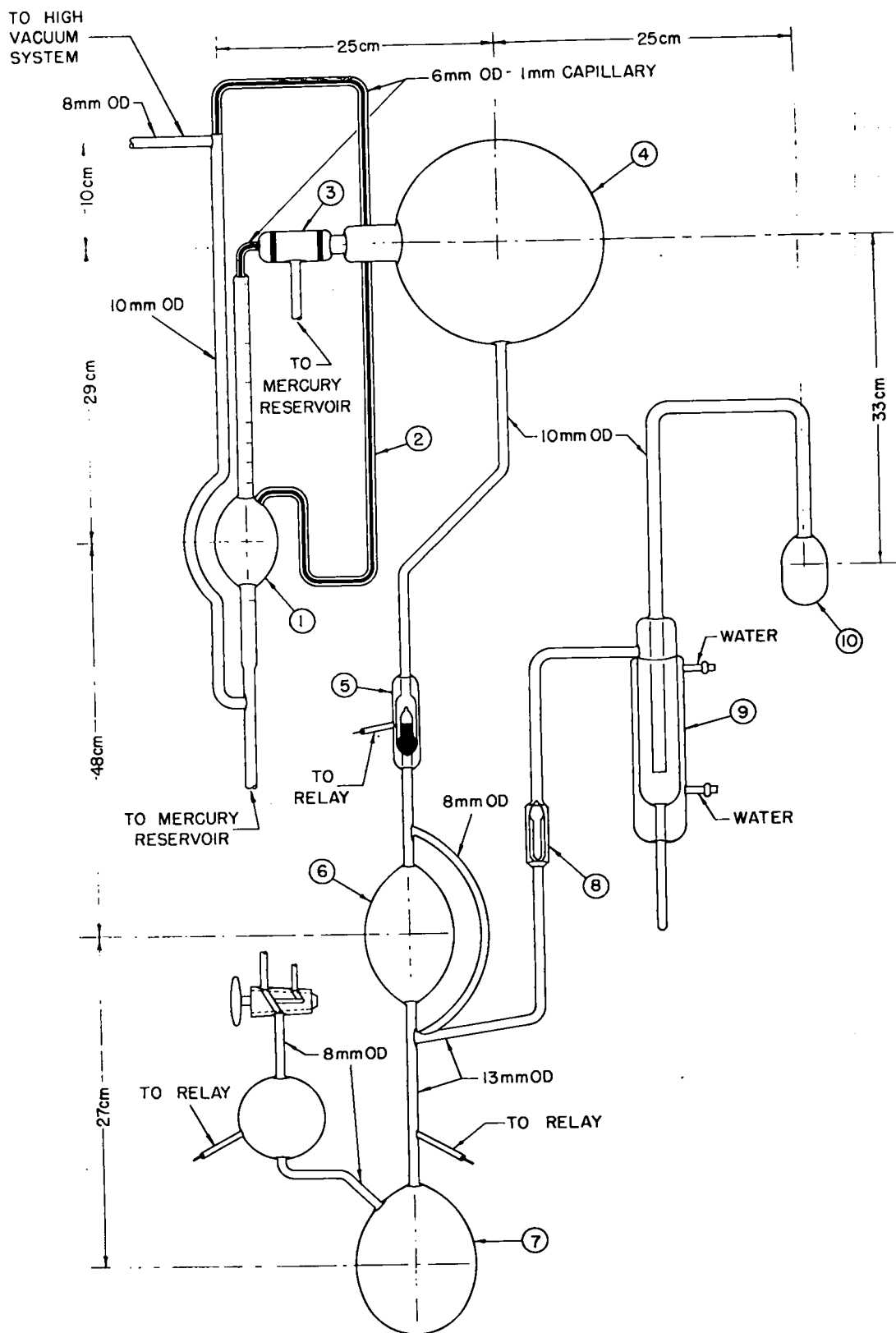

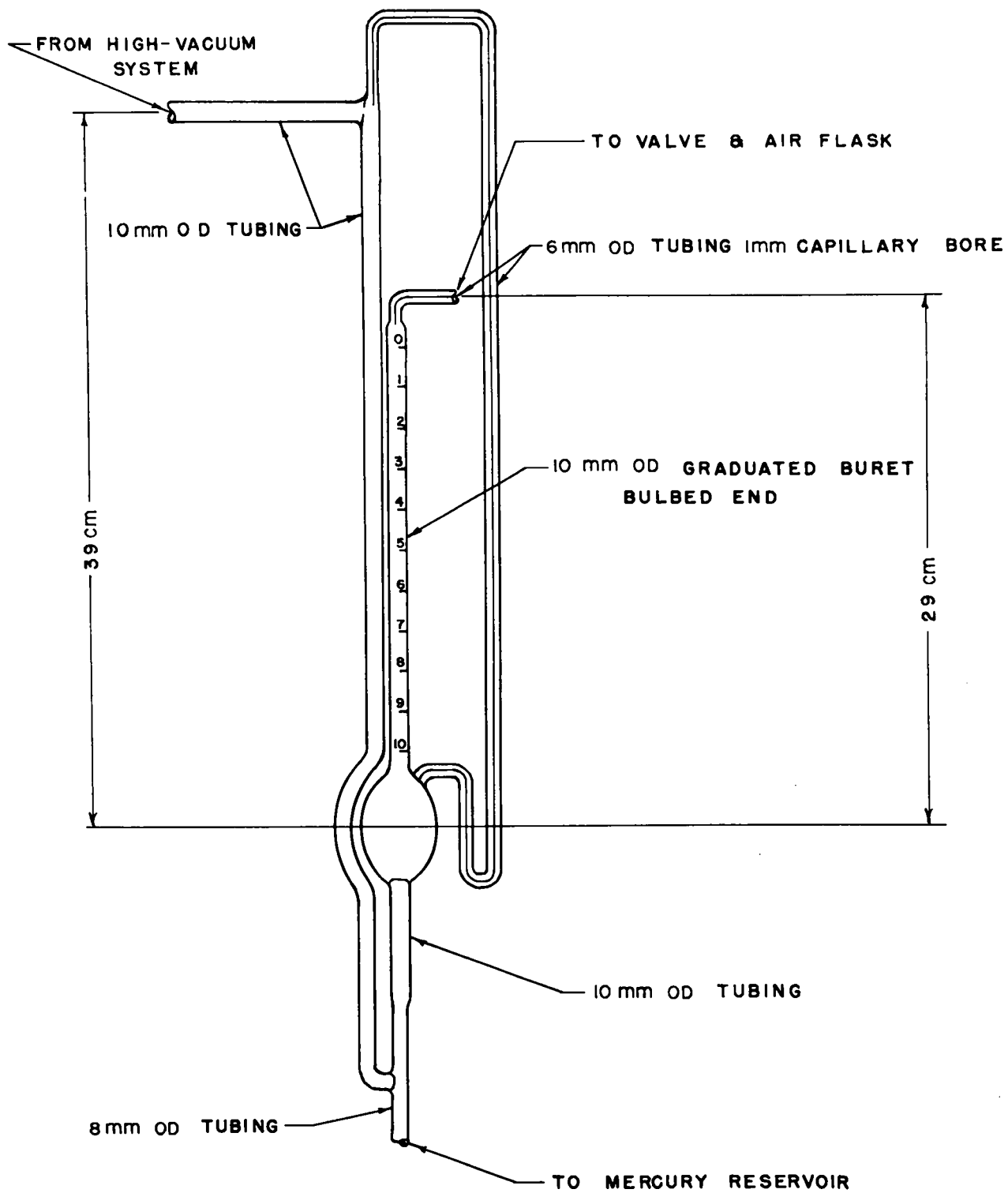

go through.

The reagents used in the analysis system are copper at 700° to remove residual oxygen, magnesium perchlorate to remove water, manganese dioxide at 225° to remove sulfur dioxide and to oxidize carbon monoxide, if any is present, and soda lime to remove carbon dioxide.

The gas analysis system may be isolated from the high vacuum system by means of a cutoff which contains two glass check-valves (IA-58). When this cutoff is closed it is possible to "break the vacuum" in the high vacuum system while keeping the gas analysis system evacuated.

(4) Procedure

Oxygen is produced by heating Bakers C.P. mercuric oxide. Since the first portions of gas collected from this material often contain traces of CO_2 , approximately two liters of gas are pumped off and discarded. Following this the gas is collected in the evacuated storage bulb. This gas is analyzed by measuring out around 10 cubic centimeters and passing it through the hot copper reagent at the inlet of the Prescott apparatus. The residual gas collected into the analysis pipet is analyzed for carbonaceous gases. Ordinarily the oxygen will contain less than a total of 0.1 mm.^3 of CO_2 per cubic centimeter of oxygen. Enough oxygen may be stored in the storage bulb to last for a large number of analyses.

The high vacuum system is kept free of carbon dioxide by breaking the vacuum with carbon dioxide free air. When the loading manifold or reaction vessel is removed, a slow stream of carbon dioxide free air is allowed to escape from the openings.

Uranium samples are pickled with 1:1 nitric acid, rinsed with water, and dried. Plutonium samples are washed in acetone and dried.

When the samples are loaded and crucible and reaction vessel are in place, the system is evacuated and the diffusion pumps are turned on. After the diffusion pumps have been in operation about ten minutes, the entire high vacuum line with the exception of the loading manifold, reaction vessel, and diffusion pumps, is flamed while the crucible is heated at 1250° C. After the crucible has been heated at this temperature for several hours the system is checked to determine whether outgassing is complete. This is done by raising the cutoff leading to the outgassing pumps, lowering the cutoff leading to the collection pump, raising the bypass cutoff, lowering the cutoff between the high vacuum and gas analysis systems, and collecting the gas through the hot copper tube into the collection pipet in the gas analysis line. The usual blank taken at 1200° C is collected in a three minute interval by ten strokes of the Toepler pump in the gas analysis system. When less than 0.10 mm³ of gas is collected in this manner, outgassing is considered complete.

Now with the crucible cold and isolated from the pumps,

between five and ten cubic centimeters of oxygen are introduced into the system from the oxygen supply. The crucible is heated in the oxygen for two minutes at the lowest temperature attainable (about 800°C) with the G.E. 5 K.W. input induction heater. The temperature of the crucible is increased and held at 1200°C for 13 minutes. At the end of this period collection of gas is begun by lowering the cutoff leading to the collection pump and proceeding as outlined in the last paragraph. If the volume of gas is small, that is, less than about 3 mm^3 , the gas is analyzed. If the carbon dioxide content proves to be too great, (i.e. in excess of one mm^3), the crucible is burned for several hours at 1250°C in oxygen.

When the carbon blank corresponds to about $0.1 - 0.2\text{ mm}^3$ of carbon dioxide (per cc of oxygen used) the induction heater is turned off. The sample is dumped into the cold crucible from the loading manifold and a measured volume of oxygen is introduced into the closed system. 100 per cent excess of oxygen in addition to the amount theoretically required to burn uranium and plutonium metal to oxide is used to obtain complete combustion.

A sample of uranium metal is ordinarily observed to burn in about thirty seconds after the heating oscillator is turned on. The crucible is heated a total of two minutes at the lowest possible temperature just as in the case of the blank for carbon. The temperature is then raised to 1200°C . After the temperature has been held at 1200°C for thirteen minutes the gas is collected over into the gas analysis sys-

tem.

Plutonium burns much more violently than uranium so that greater caution must be exercised in the combustion of plutonium samples. A fraction of the oxygen is added (1 to 3 cc) and the heat turned on at the lowest possible temperature for 15 seconds and then off for 15 seconds. This is done two or three times and then the time interval increased to 30 seconds on and off for several times. In case of very large samples a time interval of 45 seconds should be used. This entire procedure is repeated until all the oxygen has been added and then the temperature is increased to 1200° C for thirteen minutes and the gas is collected as for uranium.

(5) Calculation of Results

A gas composition of 89 per cent carbon dioxide is assumed in calculating the carbon content for all plutonium samples which give a total gas volume less than the volume of carbon dioxide which would be obtained from a sample containing approximately 200 ppm of carbon. The 89 per cent factor is based on the analysis of twenty six samples and is accurate within 10 per cent. If the volume of gas collected is large the factor is not consistently valid. Under these conditions the gas must be analyzed. The introduction of the factor as a time saver in running carbons has been made possible by the lowering of the purity requirements for plutonium and uranium and a resultant decrease in the required sensitivity of carbon determination. Accurate determination of less than 100 ppm of carbon is unnecessary. Hence if the volume of gas obtained is less than the volume of carbon dioxide which would be produced by a sample containing 100 ppm of carbon, the carbon

content of the sample is reported as 100 ppm.

Two methods of correcting for the carbon blank from the crucible have been used.

In method 1, blank runs are made immediately preceding and immediately following the analysis of the sample. In making these runs the procedure given above is followed using approximately equal volumes of oxygen for sample and pre and post sample blanks. All gas volumes (sample and blanks) are analyzed. The carbon dioxide volume obtained from the sample is corrected by subtracting from the volume of CO_2 produced by the sample the average volume of CO_2 in the pre and post sample blanks.

In method 2, blanks are taken before the first sample and after the last. In this way eight samples may be run successively but only two blanks are required. The gas obtained in blank runs is not analyzed. The samples are corrected by subtracting the average total volume of the pre and post samples blank from the total volume of gas produced in the burning of each sample.

Method 2 of blank correction combined with the 89 per cent factor for plutonium and the 100 ppm limit of sensitivity of carbon greatly increases the speed of carbon determination. By out-gassing the system for one half hour between samples eight samples may be handled in around twenty hours even though several of the gas volumes do require analysis.

There is reason to believe that the carbon in the metal samples may be highly segregated and for this reason an appreciable sampling error may be associated with the analysis of samples as small as 50 or 100 milligrams.

(6) References

Wooten and Guldner, Ind. Eng. Chem., Anal. Ed., 14, 835 (1942)

Murray and Ashley, Ibid, 16, 242 (1944)

Prescott, Ibid, 11 230 (1939)

LA-58

LA-153

IA-429

8.9 RADIOCHEMICAL PROCEDURE8.9-1 RadioAssay of Aqueous Plutonium Solutions

(1) Abstract

A method for estimating the plutonium concentration of aqueous solutions by means of the alpha activities of aliquots is described.

(2) Procedure

Two approximately 30 λ aliquots of the solution to be assayed are diluted with 5N HNO₃ in volumetric flasks of such a size that the dilution factor used to convert the number of micrograms of Pu that are alpha counted to grams per liter Pu concentration of the submitted solution is approximately given by

$$f = 6.2 s^2 p^2$$

where f is the dilution factor, s is the estimated concentration in grams per liter of the total amount of salts in the solution, and p is the estimated Pu concentration in grams per liter. When the initial aliquots are properly diluted, a 30 λ aliquot of each of the dilute solutions is placed on a number two microscope cover glass and is dried on it at about 80°C. The

two cover glasses are then alpha counted in a linear amplifier. The glasses are counted for two eight minute intervals each if there are less than 400 counts per minute on them or two four minute intervals if there are more than 400 counts per minute on them. An air chamber is used when the glasses have less than 3000 counts per minute, each, and a nitrogen chamber linear amplifier is used when they have more than 3000 counts per minute each. The counting data and the dilution factor, when combined with the specific alpha activity of the Pu, yield the Pu concentration of the initial solution.

(3) References

A more detailed account of this procedure is given in LA 469.

8.10 PREPARATION OF SPECIALLY PURIFIED REAGENTS - Edward Wichers

In the analytical work on uranium and plutonium it was necessary in many instances to use reagents of a higher degree of purity, especially with respect to light elements, than those commercially available. Some specially purified substances were needed for other purposes than as analytical reagents. The methods by which these materials were prepared will be outlined in the following paragraphs. Details of manipulation that are in common laboratory practice will not be given. Many of the methods will be recognized as commonly used for the substances in question of similar ones. In several instances methods were improvised to suit the existing requirements. Speed and convenience of operation were major considerations in the choice of methods.

References to the degree of purity achieved, when given, are usually on the comparative basis, since it is unsafe to assign absolute values to quantities of the small magnitudes involved without giving in detail the methods by which

they were determined. In some instances the criterion of purity was simply that the reagent gave a sufficiently low "blank" to be suitable for the purpose at hand.

It is well known that careful attention to cleanliness of apparatus and surroundings is essential in the preparation of substances of high purity. The exceptional cleanliness maintained in the chemical laboratory at Los Alamos, especially with respect to dust-free air, contributed very greatly to the ease with which the work herein described could be done and the measure of success that was realized.

8.10-1 Water and Mineral Acids

For the purification of water and of hydrochloric, nitric, and sulfuric acids the all-quartz still illustrated in Figure 51 was used. The partial reflux column was packed with pieces of fire-polished fused quartz tubing, about 5 millimeters in diameter and 6 - 7 millimeters long. The boiling flask (still pot) was heated with a small electric stove. The usual rate of distillation (except for sulfuric acid) was 150 - 250 milliliters per hour. For sulfuric acid the still pot was insulated with a heavy coat of asbestos paste and the reflux column was provided with an electrical heating mantle. Nitric and sulfuric acids were distilled at approximately the constant-boiling composition. In accordance with usual practice, head and tail fractions were discarded, although this was probably not important with respect to purification from light elements. Receivers were quartz flasks or bottles. In a few instances Vycor flasks were used. Water and acids purified by single distillation in these quartz stills were found sufficiently pure to meet all requirements.

In the case of hydriodic acid the main purpose was to separate it from the

Figure 51

All Quartz Still for Purification of Water and
Mineral acids.

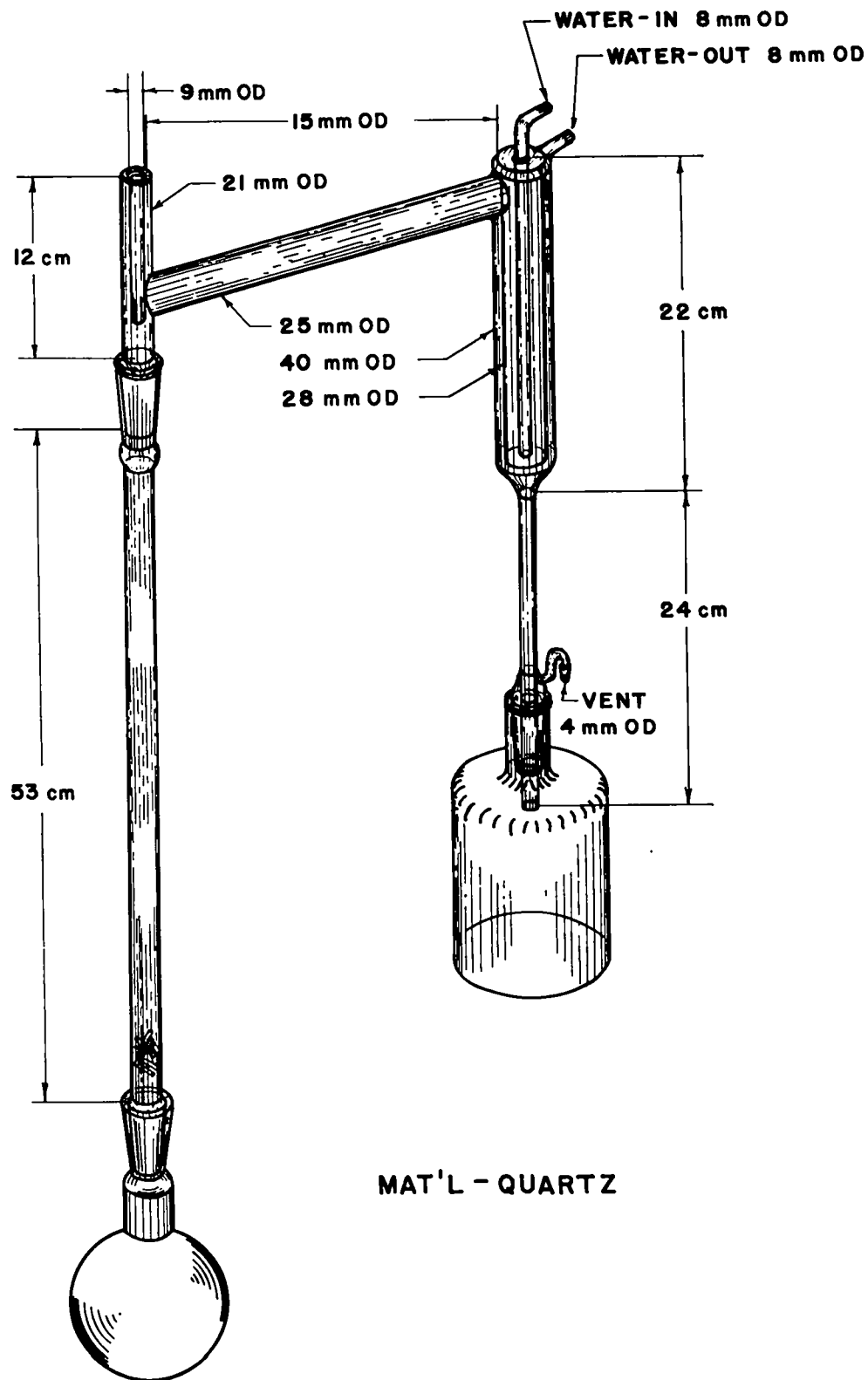

hypophosphorous acid used as a preservative in the commercial reagent. The still, partial reflux head, and condenser were of Pyrex glass, as were also the bottles used as receivers. Iodine was added to oxidize nearly all the hypophosphorous acid in the batch to be distilled. A stream of carbon dioxide was passed through the still and receivers while the acid was distilled. When receiver's were sealed without admitting air, iodine was not liberated even on long standing in strong daylight.

When the reagent grade of commercial hydrofluoric acid was distilled from a platinum still provided with a short reflux column packed with platinum gauze, the distillate was unsatisfactory with respect to its content of aluminum. This was true whether a platinum or a ceresin bottle was used as the receiver. It was conjectured that the platinum ware had been buffed with an aluminum oxide paste, which could not be removed from the surface by ordinary cleaning technics. A satisfactory acid was prepared by absorbing hydrogen fluoride gas in water contained in a copper beaker, the inside surface of which had been thoroughly etched with nitric acid. Later a satisfactory reagent was similarly prepared in a platinum bottle, the inside surface of which had been digested with fused potassium pyrosulfate for several hours.

8.10-2 Organic Compounds

(1) Triethyl benzyl ammonium hydroxide

An approximately 0.5 N solution of this base was used in connection with a spectrographic determination of traces of silicon, as an indirect determination of fluorine. The principal requirement as to purity was, therefore, a very low silicon content. The compound was readily prepared by treating triethylamine with benzyl bromide in acetone solution and by metathesis of the triethylbenzyl ammonium bromide with silver oxide. The organic substances were available in adequate

purity but silver oxide was not. Silica-free sodium hydroxide needed for the preparation of silver oxide could have been rather easily prepared, but the available silver salts did not have a low enough content of silica. A different approach was therefore used for the first preparation of the organic base. This was to use thallos hydroxide instead of silver oxide for the metathesis with the $R_3R'NBr$.

The available thallos hydroxide contained too much silica, but a satisfactory solution of it was prepared by electrolyzing a slightly acid solution of thallos sulfate with a mercury cathode and a platinum anode enclosed in an alundum thimble. The resulting thallium amalgam was transferred to a platinum dish, covered with a film of water, and allowed to react with air while protected from dust in a desiccator. The solution thus obtained was titrated and treated with a slight excess of the $R_3R'NBr$. The solution of $R_3R'NCH$, decanted from the precipitate of $TlBr$, was found to be adequately low in silicon.

Two ways were tried successfully to obtain a solution of silver nitrate sufficiently low in silica to be used with specially prepared sodium hydroxide for producing silver oxide. One was to melt silver (which contained silicon previous to the treatment) on a cupel of calcium oxide and to keep it molten for several minutes. This scorifying process yielded a button of silver which showed no silicon by spectrographic examination. The purified silver was dissolved in nitric acid distilled in the quartz still previously described. The other

APPROVED FOR PUBLIC RELEASE

method was to dialyze a solution of silver nitrate through a cellophane membrane. This trial was based on the presumption that silicon present as an impurity in a readily crystallizable salt such as silver nitrate occurs as silicic acid. If so, one could hardly expect to remove it by filtering or centrifuging a solution of the salt. An impurity of this kind might be readily eliminated by dialysis of the solution, but without such a treatment it might well persist through a series of recrystallizations. In this instance, at least, dialysis through cellophane yielded a solution of silver nitrate which contained about one-tenth as much silica as the starting material and was satisfactory for preparing "silicon-free" silver oxide.

The sodium hydroxide solution used to precipitate the silver oxide was prepared by electrolyzing a solution of sodium chloride with a mercury cathode and allowing the sodium amalgam to react with quartz-distilled water in a platinum vessel. The electrolytic cell had a stopcock at the bottom to permit drawing off most of the amalgam without including the portion in contact with the electrolyte. This was done also in preparing the thallium amalgam previously mentioned.

There was little to choose from between the thallos hydroxide and the silver oxide procedures for preparing the $R_3R'NOH$.

(2) Gallic acid

This substance was commercially available only in a rather impure form, containing far too much of the light-element impurities. At first it was purified by a single recrystallization from a rather concentrated aqueous solution, followed by a molecular distillation. A single recrystallization from a 6 per cent aqueous solution, which had been shaken with a small amount of a decolorizing carbon (Norite) and filtered to remove most of the colloidal

and insoluble matter which the crude starting material contained, yielded a better product. Two additional recrystallizations failed to show significant further improvement. It was suspected that the troublesome impurities might be present as fine suspended matter not completely removed by the filtration. Dialysis through cellophane was unsatisfactory, apparently because the cellophane contributed calcium and magnesium to the solution. Thereupon three successive crystallizations from water, each preceded by a double filtration through a fine fritted glass filter, yielded a product distinctly purer than the first crop and adequately low in light elements to meet the requirements.

(3) Cupferron

The commercial reagent contained too much calcium, magnesium, sodium and aluminum to be satisfactory for certain light element analyses. An aqueous solution of the compound was treated, in a separatory funnel, with enough hydrochloric acid to precipitate the acid form of the organic compound. The acid form is almost insoluble in water, but very soluble in ether. The suspension was extracted with ether and the aqueous solution discarded. After washing the ether solution two or three times with a little water it was poured into a platinum dish (cooled with ice), containing enough dilute ammonium hydroxide to regenerate the ammonium salt. The ether was evaporated and the solution concentrated until a stiff mush of crystals formed on cooling. On the surface was a layer of tarry matter resulting from the partial decomposition of the acid form while in ether solution. The whole mass was warmed to redissolve the crystals and poured into about 2 volumes of redistilled acetone. A homogeneous solution was obtained, from which the cupferron was almost completely precipitated by adding about 6 more volumes of acetone. The crystals were drained by suction on a fritted glass funnel and washed with acetone. The product was nearly free of tarry decomposition products and was

much better than the starting material with respect to the inorganic impurities.

(4) Methyl alcohol

Methyl alcohol used for boron determination was distilled over sodium hydroxide in an all-quartz still with a partial reflux column packed with crushed quartz. The charge was 850 milliliters of alcohol (in a 1-liter boiling flask) and 7 - 8 grams of NaOH pellets. A bead of porous gold was used to minimize bumping. The rate was about 250 milliliters per hour. Small head and tail fraction (50 - 75 milliliters) were discarded. The distillate contained not more than 0.0004 part per million of boron. The factor of improvement over the starting material was about 10.

(5) Nitrobenzene

This material was not used as a reagent but as an electro-optical shutter for polarized light (Kerr cell). The criterion of purity was an exceptionally low electrical conductivity (about 10^{-12} mho). Water was thought to be the most important impurity. The commercial product was distilled at a pressure of about 3 millimeters of Hg through a vacuum-jacketed fractionating column after standing over calcium oxide in the still pot overnight. The conductivity of the distillate was not significantly lower than that of the starting material. The distillate was then fractionally frozen. Again there was no improvement in conductivity. To test the effect of water on the conductivity some of the starting material was shaken with water periodically for 2 hours. This increased the conductivity by only 20 per cent.

The results of this work were inconclusive except to indicate that the normal impurities in nitrobenzene have little effect on its conductivity. The conductivities observed were believed to be of the same order of magnitude as those reported by H. J. White in the Review of Scientific Instruments, Volume 6, page 22 (1935). It became evident, however, that to measure conductivities of the order of 10^{-11} to 10^{-12} reciprocal ohms the conditions of measure-

ment must be closely specified.

(6) Acetone and Butyl Alcohol

These solvents were purified by distillation through a rather efficient fractionating column. The apparatus was of Pyrex glass.

(7) Ammonium Carbonate

The material was used not as an analytical reagent but in the course of purifying other substances. The commercially available reagent (which is of a rather high order of purity with respect to inorganic constituents) was sublimed in a 3 liter Pyrex beaker. A platinum dish full of ice, sitting on the beaker, was used as the collecting surface.

(8) Oxalic Acid

This substance also was used as a reagent in the purification of other substances, rather than for analysis. Its importance in preparing salts of the rare earths, uranium, and plutonium warranted a more careful study of its purification than was required of most of the other specially prepared substances. The commercially available reagent grade of oxalic acid is of a rather high order of purity. It was found that any desired degree of purification could be accomplished by repeated crystallizations from a hot aqueous solution. For use in the routine purification of uranium recovered from residues, by precipitation of uranyl oxalate, the commercial reagent was dissolved in hot water, the solution filtered, and then cooled rapidly to get a mass of rather small crystals. The crystals were drained by suction and air-dried.

To attain a very high degree of purity the acid was recrystallized very slowly two or three times. This was done in round-bottomed Pyrex flasks filled to the neck with a filtered solution nearly saturated at 90°C, and buried in a thick layer of granulated cork. The solution was mechanically stirred with a Pyrex glass stirrer, the stem of which passed through a hole in the stopper

of the flask. As the solution cooled, small crystals of oxalic acid were dropped in from time to time to make sure that crystal growth would start when the solution reached the temperature at which it was saturated. For volumes of 2 liters it took 6 days for the temperature of the solution to fall from 84° C to 30° C (3 days to 35°). The acid crystallized in large, nearly transparent masses. General considerations relating to the separation of crystals from a solution suggested that a slow crystallization of this kind would result in a higher degree of purification than the procedure of rapid cooling so commonly practiced in the laboratory and sometimes recommended in chemical literature. To determine which was the better procedure, at least for oxalic acid, two 3500 gram lots (5 liters of solution, saturated at 90° C) of identical material were recrystallized 3 times. One was treated by the slow process described above. Eight days was required to cool this lot. The other lot was crystallized rapidly by cooling the flask full of solution under the tap and constantly shaking it until it reached room temperature. The mass of small crystals was drained by suction on a Buchner funnel. Samples of the first and third recrystallizations of each lot were carefully ashed and the residue analyzed by spectrographic methods in comparison with the starting material. The results were as follows, expressed in parts per million. The letters "nd" signify "not detected".

<u>Impurity</u>	<u>Original Material</u>	<u>First Recrystallization</u>		<u>Third Recrystallization</u>	
		<u>Fast</u>	<u>Slow</u>	<u>Fast</u>	<u>Slow</u>
Be	nd(<.001)	nd	nd	nd	nd
Na	.3	.07	.02	.015	.0006
Mg	.3	.3	.003	.012	.0006
Al	.1	.2	nd (<.07)	.06	nd (<.015)
Ca	10	3	.01	.03	<.0003
Sn	.3	.3	<.1	.06	nd (<.03)
Pb	.7	.7	<.1	.06	.03

It is realized that the conditions described are far from ideal for growing large and pure crystals, especially since the rate of growth was highest at the time when the total solid surface was smallest. Nevertheless it is clear that the method used afforded much better conditions than those existing in the rapid crystallization.

(9) Ammonium Oxalate

This salt was purified by slow recrystallization from a hot aqueous solution, by the procedure used for oxalic acid. It was used in connection with other preparations rather than as an analytical reagent.

8.10-3 Inorganic Solids

(1) Calcium Oxide

The procedure used began with the addition of diluted sulfuric acid to a filtered solution of calcium nitrate. The precipitated calcium sulfate was well washed and then digested at room temperature with a solution of ammonium carbonate for 2 - 4 hours. This partially converted the sulfate to carbonate. After washing out most of the ammonium sulfate the residue was treated again with ammonium carbonate to complete the conversion. After thorough washing on a fritted glass filter the carbonate was either dissolved in nitric acid to yield a solution from which calcium sulfate was reprecipitated or it was treated directly with sulfuric acid. Thereafter the whole cycle was repeated several times. Finally the carbonate was ignited to oxide.

A variation was to convert the carbonate to oxalate by digestion with a solution of oxalic acid. The oxalate was washed and treated with sulfuric acid to form the sulfate as the first step of the next cycle. The cycle of three conversions (sulfate-carbonate-oxalate) was repeated several times. Although spectrographic analysis never showed that magnesium and sodium

were as completely eliminated as was desired, possibly because of contamination of the small batches before they were analyzed, comparisons of samples from the successive cycles clearly showed progressive purification. It is believed that either of the two cycles should be very effective in separating calcium from most impurities other than barium and strontium.

(2) Magnesium Oxide

A hot solution of magnesium sulfate was mixed with one of ammonium sulfate in equi-molecular proportions. On cooling, the double salt $MgSO_4 \cdot (NH_4)_2SO_4 \cdot 6H_2O$ crystallized. This salt has a favorable solubility curve and good crystallizing behavior. It was crystallized slowly in the manner described for oxalic acid. For a volume of 5 liters, 5 days was required for cooling from about $90^{\circ}C$ to nearly room temperature. A faintly acid solution of the double sulfate was treated with a solution of ammonium oxalate to yield magnesium oxalate. This salt is not very soluble in water but it precipitates rather slowly and the yield is not very good if the oxalate is not added in an amount close to the stoichiometric proportion. However its use in conjunction with the crystallization of the double sulfate was believed to aid purification. More important, it could be readily ignited to the oxide, which was the desired end product.

A comparison between slow and fast crystallization of the double sulfate, similar to that made for oxalic acid, showed that slow crystallization was advantageous in this instance also.

(3) Beryllium Oxide

Work on this preparation was not completed. The procedure of purification chosen was fractional distillation of the acetyl-acetone compound, which was prepared by methods described in the chemical literature. In view of the fact that very few elements form volatile compounds with acetylacetone

it is believed that a high degree of purification could be attained with less effort than is usually needed to prepare pure compounds of the lighter elements. However the work was discontinued before final spectrographic determinations of purity were made.

(4) Sodium Hydroxide

The requirement was a 3 N solution with a very low boron content. This was readily obtained by electrolyzing a solution of sodium chloride or sodium hydroxide with a mercury cathode, draining off the amalgam through a stopcock in the bottom of the electrolytic cell, and allowing the amalgam to react with a small amount of water in a platinum dish. The concentrated solution of sodium hydroxide thus obtained was titrated and diluted to the desired strength. The boron content of the 3 N solution was less than .001 part per million.

(5) Gallium Oxide

The requirement was a generally high degree of purity with emphasis on the light elements. Advantage was taken of the solubility of gallium chloride in ether, a property shared by very few other elements. A solution of gallium chloride prepared by dissolving 10 grams of metallic gallium (in contact with platinum) in hydrochloric acid, was evaporated to a syrup and transferred to a separatory funnel with approximately 6 N hydrochloric acid. At a volume of 50 - 60 milliliters it was extracted with about 200 milliliters of ether. The ether solution was washed several times with 10 - 15 milliliter portions of 6 N hydrochloric acid. Spectrographic examination of a portion of the ether solution converted to Ga_2O_3 showed it to be of high purity except with respect to iron. The remainder of the material was evaporated over water, and re-extracted under the conditions described above after shaking the acid solution with a little mercury to reduce the iron to the divalent

state. Divalent iron is not extracted by ether. The extracted gallium chloride solution was now satisfactory with respect to all impurities.

To convert gallium chloride to oxide, oxalic acid in slight excess over the stoichiometric requirement was added to the partially evaporated solution. On evaporating to dryness the chloride was converted to oxalate, which was ignited to oxide (in platinum) at about 500° C.

(6) Sulfur

The requirement was a material with a very high electrical resistance when melted and cast into forms. Only small amounts were needed. Reagent grade sulfur was sealed in a glass tube with several times its volume of water. The tube was heated to melt the sulfur, then shaken vigorously to extract the liquid sulfur with water. The water became distinctly acid. After cooling, the solid sulfur was transferred to another tube and again melted and extracted. This was repeated once more. The purified sulfur was melted and allowed to freeze in an evacuated system to remove residual water.

(7) Sodium Chloride

The requirement was a material which would have the melting point of pure sodium chloride. The well-known procedure of precipitation from a filtered aqueous solution by means of hydrogen chloride was used. The product was redissolved and reprecipitated twice. The final product was carefully fused in a platinum dish to eliminate hydrogen chloride and any other volatile substances.

A small quantity of sodium chloride, of high purity with respect to light elements, was prepared by neutralizing a solution of electrolytic sodium hydroxide (see paragraph 4) with quartz-distilled hydrochloric acid and evaporating to dryness in platinum.

(8) Iodic acid

The commercially available reagent was recrystallized three times from

a hot aqueous solution moderately acidified with nitric acid.

(9) Thorium Oxide

Of several methods tried, precipitation of the oxalate proved best with respect to convenience as well as to separation from a variety of impurities, especially light elements. For repeated precipitation the oxalate was dissolved in hot concentrated hydrochloric acid. On diluting this solution and adding a small additional amount of oxalic acid the oxalate reprecipitated. The oxalate was washed free of chloride and ignited to the oxide. This method, of course, affords no separation from rare earths.

(10) Ceric Oxide

For cerium, repeated precipitation of the oxalate also proved adequate. No advantage in purification from light elements seemed to be gained by alternating precipitation of cerous oxalate with that of cerous hydroxide. The oxalate can be dissolved (with decomposition) in hot concentrated nitric acid and thus prepared for reprecipitation. To separate the cerium from other rare earths, the nitric acid solution was treated with potassium bromate to oxidize the cerium to the quadrivalent state, after which the addition of ammonium phosphate caused the precipitation of ceric phosphate. This precipitate was bulky and difficult to wash. It was dissolved by suspending it in water and digesting with hydrogen peroxide. From the resulting solution cerous oxalate was reprecipitated. Ignition of the washed oxalate at about 1200° C yielded the dioxide.

(11) Anhydrous Rare Earth Chlorides

Several kilograms of anhydrous cerous chloride and a small amount of anhydrous lanthanum chloride were prepared by treating purified oxalates of the two elements with hydrogen chloride. The hydrated oxalate (previously air-dried at room temperature) was placed in quartz boats in a 70 millimeter quartz tube heated by a tubular furnace. Hydrogen chloride was passed

through a tube at a temperature not over 80 - 90° C. until no more gas was absorbed. The temperature was then raised rather rapidly to 270° C, and the current of hydrogen chloride continued until the evolution of water ceased. Thereafter the temperature was raised gradually to 450 - 500° C. During this period there was usually a small additional evolution of water. The temperature was finally raised to about 750° C and held there until the chloride was perfectly white. The grey color which appeared during the intermediate stage of heating (probably due to carbon) was cleared up by adding a little carbon dioxide to the hydrogen chloride. The time required for the entire operation was 8 - 10 hours.

The procedure, which is a modification of that described by Robinson, Proc. Roy. Soc., volume 37, page 150 (1884), proved more convenient and fool-proof than dehydration of the hydrated chloride, which has been more commonly used. It is important to saturate the oxalate with hydrogen chloride before letting the temperature rise above about 90°. Conversion of an oven-dried oxalate was not successful.

(12) Uranium Oxide

U_3O_8 for use as a spectrographic standard was prepared by the ignition, with a final temperature of 1000° C, of uranyl oxalate. This salt was precipitated from a solution about 2 molar with respect to uranyl nitrate and about normal with respect to nitric acid. A hot solution of oxalic acid, containing about 10 per cent more than the stoichiometric requirement, was added, with stirring, to the uranium solution. The mixture was digested in a boiling water bath for 30 minutes to one hour. After cooling, the salt was drained by suction on a Buchner funnel and washed with several small portions of water. The factor of purification was very good with respect to the light elements, including boron, and also with respect to

many of the heavy metals. One or two reprecipitations were usually made. For this purpose the salt was ignited and the oxide dissolved in nitric acid.

Contributors: Technical and Scientific Personnel Contributing
to Work Done in Chapter 8.

Sections 8.2 - 8.8

E. C. Anderson	Janet Kreiner	J. E. Roberts
W. H. Ashley	E. J. Lang	H. Rudoff
Myrtle C. Bachelder	W. H. Langham	J. L. Silver
J. P. Balagna	D. Lipkin	C. R. Simi
W. A. Barr	J. A. McCall	D. E. Smith
L. M. Berry	W. K. McKie	R. W. Spence
H. E. Boaz	C. F. Metz	W. Spindel
W. E. Cady	J. P. Miller	P. Stillson
J. J. Chap	R. S. Miller	D. Swinehart
J. G. Conway	C. C. Minkinen	W. H. Throckmorton
Helen S. Dunham	N. H. Nachtrieb	S. Weiss
R. Fearing	F. Numerof	S. I. Weissman
J. G. Feibig	L. P. Pepkowitz	S. Wexler
R. J. Gettens	M. L. Perlman	B. S. Wildi
Norma Gross	H. A. Potratz	Elizabeth Wilson
R. C. Hirt	L. V. Quartararo	A. P. Wolf
I. L. Kintish	C. N. Rice	

Section 8.9

Rebecca Bradford	W. G. Hudgins	J. E. Roberts
Alice Browning	S. R. Johnson	A. C. Wahl
Mary E. Hahn	W. W. Lowe	Dorothy M. Wood
Leona M. Hansen	Elizabeth Maxwell	
Clara B. Hirt	Mary A. Nachtrieb	

Section 8.10

W. E. Browning, Jr.	M. Kahn	Inez O'Brien
I. E. Davis	B. L. Kelchner	E. Wichers
K. M. Harmon	H. E. Menker	

CHAPTER 9CONTROL MEASURES FOR RADIOACTIVE HAZARDS

W. H. Hinch, E. W. Molloy, J. F. Tribby

9.1 INTRODUCTION

The problems involved in the control of radioactive hazards are many and varied. An attempt has been made in this chapter to indicate some of the more important and prevalent health hazards encountered by workers in the CMR Division and the preventive measures taken by the Health Instrument Group (H.I. Group) to minimize these hazards.

No effort has been made to give more than minimal physiological aspects of radioactive exposure, as the H. I. Group has not been directly connected with this phase of the health program.

9.2 PERSONNEL MONITORING9.2-1 Methods of Determining Personnel Exposure

The principal hazardous materials ⁽¹⁾ concerned with in this chapter are plutonium (Pu), polonium (Po), uranium (tuballoy) - particularly U-235 (25), and to lesser extent mercury and other heavy metals that cause kidney damage. Plutonium and polonium are extremely toxic elements because of their radioactive properties, and it is mainly for the detection of these two substances that alpha detecting electronic instruments have been developed. Tuballoy and 25 are classified along with mercury as chemically toxic substances as they are too mildly radioactive to act as serious radioactive hazards; that is, much smaller amounts are necessary to be chemically toxic than radioactively toxic.

(1)

These radioactive substances will often be referred to in this chapter as active material, hazardous materials, or simply as contamination. Highly contaminated areas are often referred to as "hot".

Protection of personnel against these hazards requires a complete knowledge of each individual exposure history, means of detecting these hazards, (alpha, beta, and gamma radiation detecting instruments), development of health-safety rules for handling these substances, and carefully planned operating procedures developed especially to guard against radioactive hazards.

The individual exposure history is obtained by:

- (1) Interviewing all new division personnel, or personnel changing from one job to another within the division.
- (2) Monthly hazard data sheets.
- (3) Joint health-safety surveys of all laboratories.
- (4) Individual health-safety reports for each laboratory.
- (5) Urinalysis reports.
- (6) Contaminated operation records.
- (7) Contaminated accident records.
- (8) Study of nose and hand count records.

Hazard data sheets (2) are distributed monthly by the Medical Group to all division Group Leaders, who in turn fill out the required information (type and degree of exposure for each person in his group) and return the sheets to the Medical Group. Three copies are made by the Medical Group for each Group Leader and one copy is filed in the Health Instrument office. The joint health-safety survey (3) of the entire area is made monthly by the H.I. and Medical Group representatives. A careful inspection is made of all rooms and laboratories to determine the health hazards involved in each chemical operation. The individual laboratory health-safety reports (4) are submitted to the H.I. and Medical Group offices monthly, listing the following data:

- (1) Operations carried out in the laboratory.
- (2) Number of persons occupying the laboratory carrying out a particular operation.
- (3) Total amount of active material handled during the month.
- (4) Persons continually in the laboratory not handling active material.
- (5) Persons occasionally in the laboratory not necessarily handling active material.

These reports are made out individually by the person directly in charge of each laboratory.

9.2-2 Urinalysis

(1) Introduction: Urinalysis is a health procedure set up to check elimination of toxic substances from the body, or to detect abnormal excretion products produced in the body by the action of toxic substances. Essentially, the urinalysis methods referred to in this chapter and used on this project can be classified in two sections: (a) direct radioassay for a radioactive substance in the urine (plutonium and polonium); (b) albuminanalysis to detect abnormal amounts of albumin in the urine as a result of kidney damage resulting from chemical heavy metal action (thallium, 25, mercury, etc.). All persons of known thallium and mercury exposure and who show a persistent albuminuria are examined further for thallium and/or mercury in their urine.

(2) Albuminanalysis: Biological experiments have proved that thallium and 25 are poorly absorbed through the gastro-intestinal tract, and probably not at all through the intact skin. Both metals are relatively mild radioactive substances, emitting (along with their daughter products) alpha, beta, and gamma radiations. The beta and gamma radiation is toxic to the human

skin, but experiments indicate that the hands may tolerate contact with tuballoy metal for 2 hours per day indefinitely. This corresponds to a dose of 0.5 r/beta/day. 25 metal is not so well tolerated.

For the albuminalysis test, urine specimen bottles are left in washrooms of D building, Sigma building, C shop, the contaminated laundry, and building 1 D.P. West Site each Thursday morning. All personnel working with tuballoy, 25, and mercury are asked to leave a sample. The bottles are delivered to the Medical Group by an H.I. representative and tested for albumin, using the Robert's reagent. By this test slight kidney impairment due to action of 25, tuballoy, or mercury can be detected before any great harm is done, and steps can be taken to reduce the person's exposure.

(3) Po determination: Radioassays for polonium in urine are given to all personnel exposed to that element, usually once per week. This element is highly toxic because of its intense radioactivity (alpha emitting). It is dangerous only if it enters the body, as the particles do not injure the body externally (skin) in the concentrations encountered. Its short half-period (140 days) and inert decay product (lead), and the fact that polonium is not particularly concentrated in any one body organ⁽²⁾ tends to moderate

(2)

There is evidence that Po may be found in higher concentration in the heart, lungs, and kidneys than in other body organs, but not to the same extent that Pu is concentrated or deposited in the bones.

its toxicity as compared with plutonium. Therefore, the problem of personnel protection from this element is the prevention of the substance from entering the body.

The actual urine assay procedure is fairly simple. A specimen bottle is obtained by the exposed individual from the Medical Group each Saturday

evening when leaving the Technical Area or DP East Area. Monday morning the bottle containing the urine is returned to the medical laboratory for analysis. During the weekend the individual is requested not to expose himself to any contamination and to wash thoroughly before submitting the sample. It is preferable that the individual void his sample the first thing Monday morning before he has dressed. A paper label is placed on the bottle, bearing the individual's name and the time the specimen was collected.

To determine the amount of polonium in the urine, the sample is measured (usually 50 cc is used), acidified with HCl and the polonium is plated out on copper plates. The copper plates are counted in a Simpson proportional counter and the results are given as c/m per 24 hour sample.

(4) Plutonium determination and health pass: Plutonium (Pu) urine assays are given to all personnel exposed to this element to any degree. This substance is extremely toxic because of its radioactivity. It has a half-period of approximately 24,000 years and is alpha active, decaying into a mildly radioactive daughter product. It tends to be concentrated and deposited in certain bones⁽³⁾ and the rate of excretion⁽⁴⁾ from the body is slow. As with polonium, the principal means of personnel protection is to prevent entrance of the element into the body. All the procedures outlined in this chapter are set up to prevent these two elements and their compounds from entering the body, or to detect their presence and amount in the body before harm can result. As the number of plutonium counts excreted in the urine is small⁽⁵⁾ and as the probability of contaminating a urine specimen from Pu

(3) Principally the endosteum of the long shaft bones proximal to the blood forming (hemopoietic) tissue.

(4) The amount of plutonium excreted in the urine per 24 hours is approximately 1 part per 10,000 of Pu contained in the body.

(5) 7 c/m for a 24 hour sample or 140,000 d/m taking place in the body. This amounts to one microgram of plutonium or about the amount generally considered to be tolerated in the body for a lifetime without any visible harmful effects. Actually, the true tolerance may be several times greater.

present on clothes, hands, or other parts of the body is great, it is necessary to collect the 24 hour urine sample under very rigorous conditions. All possible precaution must be taken to prevent extraneous contamination, and hands and clothes must be as free of contamination as possible.

This precaution has necessitated the health pass procedure, which enables the person who is to be tested to stay away from all contaminated areas for at least 48 hours before voiding the urine specimen thereby minimizing the possibility of transferring extraneous contamination from his body and clothing to the sample. Routine health passes are given periodically to all exposed personnel, the period varying with degree of exposure.

In the case of contaminated accidents, the individuals exposed are immediately sent on health passes in order to determine whether they have received large doses or not. This immediate test is largely qualitative. A period of ten to fourteen days must elapse before the plutonium urine excretion rate approaches a constant value, thereby giving a quantitative indication of the amount of material remaining in the body.

Civilian personnel are requested to stay away from the Technical and D.P. Areas for a period of two days, during which time they must wash frequently and wear freshly laundered clothes. At 8:00 A.M. of the third day they report to the hospital. There the individual is required to shower and change to hospital clothing, placing his personal clothing in a canvas bag. His clothes are not to be touched again until the end of the 24 hour period, nor is he to leave his room except for meals which he takes in the hospital mess. Before voiding a sample, he must wash his hands thoroughly and put on a pair of cotton gloves. Effort should be made not to drink too much fluid just

before the test, so as not to produce a large volume of urine. A large volume of urine is difficult to evaporate and consumes a great deal of valuable time.

For Military personnel the health pass procedure is more complicated. Army Travel Orders are necessary for a soldier before he may be absent from the Post for the required two days. The procedure which is laid down for all military personnel and which all soldiers must follow is:

- (a) Request for this pass should be submitted to the H. I. office at least one week before the pass is to begin.
- (b) Request must contain the following information: name, rank, A.S.N., date of departure and return, and destination while on pass.
- (c) Travel orders are issued from SED Military office 24 hours before beginning pass.
- (d) Two copies are issued, one of which is turned into the SED Orderly Room on day of departure.
- (e) The soldier reports after 48 hours to the Post Hospital at 8.00 A.M. where he will remain for 24 hours. While in the hospital the procedures are the same as for civilians.
- (f) At the end of this period he will turn in the second copy of his orders to the SED Orderly Room.

Any violation of this procedure might result in the soldier's being considered A.W.O.L., and cause inconvenience to the next one who goes on a health pass. Allowances are given all military personnel for this pass; \$4.00 for two nights lodging, and meal tickets for six meals at 75 cents per meal. If the individual is married and lives with his wife on or near the Post he is allowed \$6.00 cash in place of the meal tickets.

It should be noted that all personnel on the project who have had exposure to plutonium to any degree should submit to this urinalysis before termination.

To determine the amount of Pu contained in the urine the entire 24 hour specimen is evaporated to dryness and the residue is ~~wet-ashed~~ using HCl, HNO₃, and H₂O₂. This residue is dissolved in HCl, precipitated as the hydroxide, redissolved in HCl and extracted by chloroform and cupferron. A lanthanum fluoride precipitation carrying the Pu is carried out and the precipitate is radio-assayed for Pu. A Simpson proportional counter is used for this assay and the counts are recorded as c/m/24 hour sample of urine.

9.2-3 Nose Counts

(1) Introduction: Nose counts are taken daily by all personnel exposed to either plutonium or polonium to any degree. This health procedure is designed to detect minute amounts of radioactive material accumulated in the nostrils. These counts are taken near the end of each shift, so as to be sure to cover the major part of the working period and most of the individual's exposure during the day. It has been shown that both elements are present on dust particles in the air. Some of this dust breathed in through the nose is filtered⁽⁶⁾ out of the nostrils, part of the dust sticks to the mucus membrane of the upper respiratory tract but the rest of the dust reaches the bronchii and lungs. Much of the dust accumulated in the nostrils is blown out along with the nasal secretions by the individual, and most of the dust accumulated in the upper respiratory tract is brought into the throat by ciliary action and then swallowed, allowing most of the active material to pass through the body without absorption (Pu is absorbed very slowly, if at all through the G.I. tract). However, that part of the active material contained on dust particles

(6)

The depth to which the dust particles penetrate is a function of the dust particle size. The smaller the particle size, in general, the deeper the particle penetrates in the respiratory tract.

which reaches the lungs is absorbed fairly rapidly and distributed by the circulatory system throughout the entire body.

Experimental evidence has shown a good correlation between urine assays for plutonium and polonium and the individual's nose count history, thus, making the nose count a very important monitoring procedure. Both nostrils should show practically the same count if the contamination contained in them is actually due to a filtering action on contaminated air. Variable counts in separate nostrils are probably due to accidental action, such as placing a finger in one nostril, and when such counts are encountered only the lowest count is considered of any importance.

Tuballoy and 25 contamination in air is not monitored by nose counts as it is too feebly radioactive to be detected by ordinary procedures. However, ordinary precautions, such as are laid down in the Health Safety Rules⁽⁷⁾ will normally prevent dangerous air contamination exposure from these two substances. Mercury contaminated air is monitored by ordinary standard analytical procedures. Further discussion of air contamination due to radioactive substances will be taken up in the section of this chapter entitled "Air Monitoring and Air Samples".

(2) Routine nose counts: The actual procedure for taking nose counts is relatively simple. Each person who is exposed to Pu or Po and who works in the Chemistry and Metallurgy Division has an individual nose count box in which filter paper swabs from each nostril are placed. Formerly, when only a small number of counts were taken, the boxes and materials, instruments, etc., were carried around D building by hand. However, as the number of buildings and personnel handling these two elements increased, push type carts were

(7)

See Section 9.7.

developed and placed in the three strategic areas, D building, D.P. West, and D.P. East. Materials carried on each cart are: nose count boxes (one for each individual), one set of forceps for rolling the filter paper, one set of forceps for removing the filter paper from the applicator, bottles of distilled water, absolute ethanol, sodium citrate solution (5 per cent), and the filter paper swabs. The swabs consist of a strip of filter paper 3" by $\frac{3}{4}$ " glued to the end of a small wood applicator and wound tightly about this end.

One swab is used for each nostril. Before inserting the swab in the nostril it is moistened with distilled water. After swabbing the nostril thoroughly, the filter paper is unwound from the applicator and placed in the individual's box.

The filter paper must be allowed to dry (usually 24 hours) before it is counted. However, in emergencies it may be counted wet, assuming one-half of the counts on the paper to be obscured by moisture. A new technique developed to dry the filter paper immediately consists of heating the wet paper under a bank of infra-red lamps (paper must be at least eight inches from the lamps). By this means the paper may be dried and ready for counting in 15 minutes.

After drying, the swab from each nostril is counted on a standard alpha counter for a period of 1 to 2 minutes. During the counting procedure the background of the counter is checked and deducted from the total count to give the true count on the swab. Counts are recorded as c/m for each nostril.

Some 250 nose counts are given daily at this site. A daily record of all counts are placed on bulletin boards so that individual results are available for inspection by laboratory members. Copies of this daily record

are kept on file in both the H.I. and Medical Group offices and are referred to in determining personnel exposure, and serve as a criterion in scheduling health passes for persons exposed to plutonium.

(3) Special nose counts: A second type of nose count is given aside from the routine daily counts just described. That is, the special nose count, which is given during contaminated operations or during emergencies. They are given to personnel not included in the above procedures, such as outside service workers after working in contaminated surroundings, and to all personnel after contaminated accidents. A complete record of all special nose counts is kept on file in H. I. and Medical Group offices. This record serves as a criterion for determining the exposure history of all outside service workers and the exposure suffered by any person involved in a contaminated accident.

9.2-4 Hand Counts

(1) Introduction: Hand counts are a monitoring procedure set up to check the hands in order to determine the contamination due to radioactive substances. These counts are recorded by alpha detecting electronic instruments. Pu and Po are the principal elements to be counted. Hand counts may be considered to be of two kinds. The first type of hand count is taken by the individual himself with the aid of hand counters⁽⁸⁾ placed at convenient places around a contaminated area or in "hot" laboratories. It is the duty of all persons who are exposed, in these areas, to check their hands often for alpha contamination. The second type of hand count procedure enables the H. I. Group to obtain daily records of the hand count of all CMR Division personnel leaving for lunch or at the end of shifts. This procedure will be discussed under "Hand Contamination Control".

(8)

See section 9.4.

Contamination on hands is dangerous because of the possibility of transferring the active material to the mouth and nose and thereby to the G. I. and respiratory tracts.

In cases of hand or finger cuts, a highly contaminated hand would be most dangerous because of the danger of absorption of the material directly into the bloodstream. It is not impossible that active material might be transferred to a non-contaminated area by some careless individual who has neglected to keep his hands clean. It is doubtful if appreciable amounts of Pu are absorbed through the intact skin, but there is some evidence that Po does so to a limited degree. To prevent the above possibilities, persons are urged to keep their hands below tolerance ⁽⁹⁾ at all times. To aid in this purpose, various types of cloth and rubber gloves are available from the H.I. Dispensary.

(2) Hand contamination control: Double plate hand counters are placed near the exits of D building and buildings 1 and 51 at D.P. Site. An H.I. operator is on duty at the end of all shifts and during the lunch hour in each building to operate these counters ⁽¹⁰⁾ and record the counts. Records of all

(9)

See section 9.6.

(10)

See section 9.4.

counts are kept on file in the H.I. and Medical Group offices. Before testing their hands it is required that all persons wash their hands at least once. If hands are found over tolerance the individual must re-wash until they are below tolerance. A 1:1 mixture of sodium tartrate and tartaric acid has been found to be effective in lowering hand counts to tolerance in case

of Pu contamination. The procedure for washing highly contaminated hands (Pu) is described:

- (a) Wash the hands first with liquid sulpho-soap and plenty of hot water.
- (b) Rewash hands in above tartrate mixture. Use one small handful of mixture in a bowl of hot water.
- (c) Scrub hands with a brush for three minutes, keeping hands immersed in the solution.
- (d) Rinse, rewash with soap and water.
- (e) It is advisable not to use the alkali bar soap in cases of high hand contamination.

For Po contaminated hands, a 3 per cent solution of sodium hypochlorite has proved effective, but it is slightly corrosive to the skin. The procedure for using this solution is essentially to rinse the hands thoroughly with the solution, and then to wash off the excess hypochlorite with soap and water.

9.2-5 Contaminated Operations

To protect all persons not in CMR Division and not directly protected by the health and safety program set up for this division's personnel, and who work on contaminated objects, or in or around contaminated areas, the following procedures have been developed. The above personnel consist of Post service help (plumbers, electricians, carpenters, tanners, painters, etc.) Post firemen, and in some cases army fire and security guards and M.P. personnel. Army fire and security guards and M.P.'s are ordinarily exposed only because of being stationed around contaminated areas, and the health hazards to which these persons are exposed are not great. This type

of personnel is given two to three days training before starting to work on the project. (This training consists of the recognition of the safety problems connected with radioactive hazards and how to combat these hazards in case of fire or accidents.) They are also given routine nose counts.

The post service workers, however, are often directly in contact with many or all of the health hazards while working in the contaminated areas. For instance, a plumber repairing a "hot" dry box in a "hot" laboratory suffers direct exposure to the contamination contained in the drybox. Also, for security reasons, this individual is not aware of the scientific facts connected with radioactive health hazards as are the laboratory technicians and scientists, and therefore greater care must be taken to see that these individuals are adequately protected.

The contaminated operation procedure will afford this protection if all the rules and regulations set up are followed explicitly. Arrangements have been made with the Maintenance Office and Post Service Office to have all service workers report to the H.I. Office for instructions before beginning work in the contaminated buildings and laboratories. Before any of the above personnel commence work, they are issued a set of protective equipment; the equipment varying with the type of job and hazards. The area and objects, which require servicing, are monitored thoroughly for degree of contamination. The protective equipment usually consists of coveralls, rubber gloves, respirator, shoecovers, and surgeon's caps. If the operation is excessively hazardous, it may be necessary for an H.I. man to actually monitor the entire job, and the workers may be given additional protective equipment.⁽¹¹⁾ After

(11)

See second paragraph under Section 9.2-7.

finishing the job, the worker's hands, other exposed parts of the body, protective clothing, equipment, and tools are monitored for possible contamination, and special nose counts are given. If any individual's clothing is found contaminated he is requested to take a shower before leaving.

In addition to this, an individual record is kept of all such operations. The following information is contained in the record:

- (1) Nature of the job.
- (2) Type and degree of hazard.
- (3) Date, time of beginning and ending job.
- (4) Length of exposure.
- (5) Protective equipment issued.
- (6) Degree of contamination found on clothing and body.
- (7) Hand count
- (8) Nose count

Copies of this record are filed in the H.I. and Medical Group Offices, and are used by these offices to compile the individual's exposure history.

9.2-6 Contaminated Accidents

(1) General: A contaminated accident may be defined as any situation involving excessive or uncontrolled spreading of contamination, unnecessary and excessive contamination of hands, body, clothes, etc., injury or cutting of any part of the body while working in contaminated areas or with contaminated objects, or entrance of radioactive material into the body. Contaminated accidents may be minimized by obeying the Health Safety Rules and by following the proper chemical and analytical procedures set up for personnel protection.

The most common contaminated accidents normally encountered are:

- (a) Spillage of radioactive compounds, solutions, etc., during operations.
- (b) Cuts, bruises, or lacerations on some part of the body while working with contaminated items or in contaminated areas.
- (c) Uncontrolled escape of stored solutions containing active materials.
- (d) Accidental misplacement of contaminated objects.
- (e) Fires in contaminated areas.
- (f) Explosions (ether extractions of 49, 25, etc.).
- (g) Accidental ingestion of radioactive materials.

Spillage (a) is by far the most common of the contaminated accidents. The fact that these radioactive materials may spread over an entire building makes it imperative that they be brought under control at once. For instance, if a "hot" solution is spilled, the spot formed will at first be wet and localized. However, as the spot dries, the radioactive salts attach themselves to dust particles which are always present and are carried about by air currents, or the material sticks on the shoes of people moving about and thus is transferred throughout an entire building, in which case it is difficult or impossible to control. A few spillages, which are not immediately cleaned up by proper means, could easily render an entire building hazardous or even uninhabitable. Polonium exhibits this spreading property to a striking degree. It appears to "creep" over surfaces and penetrate into the most inaccessible spots with amazing rapidity. In addition, it readily attaches itself to dust particles that float in the air. The M and D sections⁽¹²⁾ of the H.I. group

(12)

See Section 9.3-1

have been especially trained to combat this uncontrolled spreading of active material, and these sections should be notified immediately in cases of spillage of "hot" materials.

(b), (c), (d), and (g) are discussed in the section on Health Safety Rules.⁽¹³⁾

(13)

See Section 9.7

(2) Fires and explosions: Fires and explosions (e) and (f), may be the most serious, not only by immediate destruction of life and property but also because of the volatilization of large amounts of radioactive materials. Thus a fire could possibly vaporize enough Pu or Po to render vast areas highly dangerous⁽¹⁴⁾ or uninhabitable for some period of time.

(14)

See Section 9.6 for air tolerance values.

A procedure has been developed for the Post firemen to follow in case of a fire in any of the contaminated areas. A summary of this procedure follows:

- (a) Fire at D.P. Site: All firemen will carry a smoke mask which will be put on before entering the area. The fire crew will be met at the D.P. gate by a representative of the Safety Committee to instruct them about the fire. Emergency protective clothing will be stored at the M.P. gate and will be available for the firemen at all times. Masks, coveralls and rubber gloves are absolutely necessary before entering the burning area.
- (b) Fire at the Technical Area: Emergency protective equipment will be stored in the red emergency shack just opposite to D building entrance and will be available for firemen at all times.
- (c) If any injury occurs while fighting the fire the individual should contact a first-aid representative, or if one is not available, report immediately to the Post Hospital.

- (d) After fighting the fire the firemen will discard all his protective equipment, which will be picked up by the H.I. Group and cleaned. He also must report as soon as possible to any one of the H.I. dispensaries where he will be given a special nose count. (It is probable that an H.I. representative will be available at the fire to give the nose counts during and immediately after the fire.) It should be remembered by all persons taking a nose count to refrain from blowing the nose, so that the counts obtained will be indicative of the actual exposure. If a fireman is found to have suffered an exceptionally high exposure to contamination, he will be sent on a health pass and given urinalysis for Pu or Po, or both.
- (e) All firemen exposed to any contaminated fire are to be reported to the H.I. Group by the Fire Chief.

9.2-7 Dispensing of Protective Equipment

(1) Types of protective equipment: Protective equipment is designed to protect personnel against radioactive hazards by preventing active material from contaminating the body or personal clothing, or by preventing possible entrance of these substances into the body by way of skin lacerations or by the G.I. or respiratory tracts. Clothing such as coveralls, shoe covers, smocks, gloves, safety shoes and other equipment such as respirators, gas masks, smoke masks, positive pressure air hoods, oxygen masks, face shields, and nasal filters, are the principal types of protective equipment, and they are issued through the H.I. dispensaries maintained in D building and in buildings 1 and 51 at D.P. Site.

Shoe covers, coveralls, laboratory smocks, rubber gloves and dust

respirators are issued daily to all personnel working in contaminated Tech Area and D.P. Site buildings. Certain very hazardous operations, however, require additional protective devices such as positive pressure air hoods, oxygen masks, etc. The positive pressure air hoods have proved of great value in cases of extreme air contamination, but have the draw-back of requiring an air line capable of supplying several cubic feet of air per minute at 10 to 20 pounds gauge pressure. Nasal filters (of the hay fever type) have been tried in cases of highly contaminated air exposures, but are of questionable value.

(2) Laundry operations: A laundry is maintained by the H.I. Group to launder all alpha, beta, and gamma contaminated clothing and protective equipment at this site. The laundry is composed of 25 members with the following organizational breakdown: (a) administration, (b) washing and drying operations, (c) glove and respirator processing, (d) shipping and receiving, and (e) maintenance.

The contaminated equipment when brought into the laundry is divided into two separate classes: (a) general clothing, such as shoe covers, underclothing, coveralls, smocks, towels, and (b) accessory protective equipment, such as respirators and other types of smoke gas masks, and rubber gloves. The clothing is washed in tumbler-type washers, dried in centrifugal driers, and then monitored for contamination. The clothing should meet the tolerance requirements shown in Sec. 9.6 before it is passed on to the sewing and mangling crew. This crew repairs any tears, etc. irons and folds the clothing, and sends it to the shipping or storage room. The accessory equipment demands slightly different washing and cleaning technique from that used for the protective clothing. Usually, the respirators and masks must

be washed by hand. To date no satisfactory cleaning solutions⁽¹⁵⁾ and procedures

(15)

See Section 9.3-6

have been found which are effective in cleaning rubber gloves. Actually, it has been found cheaper to replace contaminated gloves with new ones rather than to expend the time and labor necessary to decontaminate them. (About 20 per cent of the total number are successfully cleaned by washing in a 5 per cent citric acid solution). Between 80,000 and 70,000 items are processed by the contaminated laundry monthly.

Although the above procedures are set up to wash alpha contaminated clothing, there is an occasional batch of beta and gamma contaminated clothing.⁽¹⁶⁾ These

(16)

The principal source of beta and gamma contamination is radio-lanthanum (RaLa), which is used in experimental work at the Technical Area and at Bayo Canyon.

are separated from the alpha clothing and washed in a tumbler-type washer, using hot 5 per cent citric acid solution. This has proved to be a very efficient procedure in washing and decontaminating the clothing impregnated with beta and gamma emitting radiochemicals.

All laundry personnel are given daily nose counts, weekly urine albuminanalysis, routine urine radioassays for Pu and Po, and occasional blood counts. No person from the laundry has as yet gone beyond the tolerance set up on any of these tests (except an occasional high nose count), although the protective equipment handled is contaminated with any or all of the hazardous chemicals, both radioactive and non-radioactive, used on this project.

9.3 LABORATORY MONITORING AND DECONTAMINATION PROCEDURES

9.3-1 Organisation and Function of the M and D Sections

The Monitoring and Decontamination (M and D) Sections of the Health

Instrument Group have been developed principally to carry on monitoring of all rooms, buildings, and areas associated with the CMR Division processing or storing radioactive materials (mainly the alpha emitting radionuclides). In addition to the monitoring duties there are many other important secondary functions such as the decontamination of "hot" items, decontaminating and cleaning after contaminated accidents, dispensing of protective equipment, air counting, and taking hand and nose counts. Three sections are now in operation: the Technical Area, D.P. Site East (Po building), and D.P. Site West section. The Tech Area organization is typical of the three sections. This force consists of a section leader, three women to keep records, issue protective equipment and do routine monitoring, a five man crew for room survey work and accident control, two men to handle routine decontamination and special monitoring problems, two women who wash contaminated glassware, and two counting room operators to count nose swabs, air filter samples, and other special samples.

9.3-2 Room Surveys

(1) Introduction: Room and laboratory surveys are made each working period. These surveys constitute one of the most important procedures in contamination control. All rooms in which radioactive materials are processed, stored, or handled in any way are checked with electronic instruments designed for the detection of alpha, beta, and gamma radiations. The alpha detecting instruments used for these surveys are the mobile alpha survey meter, "Poppy", the portable alpha survey meter "Pee Wee", the Plute, and the Zeuto (for a detailed discussion of these instruments see section 9.4). These surveys are not intended to be an exact quantitative

radiocassay, but are only a general survey of the degree of contamination that exists in the room with a reasonable degree of accuracy. By using direct reading instruments a quick thorough scanning of a laboratory is possible without hindering the normal operations that are going on in the room.

During the early days (1943 and 1944) of the project, only a few rooms in one or two buildings in the Technical Area actually handled active materials, and then only in very small amounts. The monitoring crew at that time consisted of about four men. The only alpha-detecting instrument on hand was the immobile standard alpha counter, and the room surveys were made by swiping four or five positions in each contaminated room with a piece of oil impregnated filter paper, covering in this wiping motion a surface of about 30 square inches. This filter paper then was counted on the standard alpha counter to determine if the position that was swiped "hot" or "OK". If the the filter paper showed a count of less than 500 counts per minute the position was regarded as being "OK", if the count on the paper was between 500 counts per minute and 25,000 counts per minute the position was regarded as "hot", and if the count was greater than 25,000 counts per minute (this was the maximum range of the counter) the position was regarded as "infinity". The "infinity" count simply meant that the count on the swiped position was too great to be counted. In the early part of 1945 a mobile alpha counter known as the "Super Snoop" was developed and was used to supplement the swipe method. By using the "Super Snoop", direct readings of the contamination (in similar units) could be made by wheeling the instrument into a room and scanning or "snooping" the working surfaces of that room. This was a more accurate and efficient method of surveying a

contaminated room, but the "Super-Snoop" was deficient in many ways. It was very heavy and bulky and was not mobile enough to be moved from building to building. In addition, it was too clumsy to be used in a great many of the laboratories without damaging the equipment or annoying the personnel at work.

By 1945, the number of buildings, rooms, and personnel handling the active radiochemicals was increasing rapidly and there was an urgent need of an increasing number of more mobile alpha-detecting instruments of the "Snoop" type. The swipe method of room survey was inaccurate and slow and the "Super Snoop" was too bulky. In April, 1945, the monitoring crew (then the monitoring section under Group CM-1) was re-organized into an entirely separate group, the Health-Instrument, CM-12 Group. The functions of this new group were to develop and repair health instruments for detecting alpha, beta, and gamma radiations, and maintain a laundry for washing contaminated clothing, as well as to carry on the monitoring and decontamination function. By June, 1945, several alpha survey meters, the "Poppy", "Zeuto", and "Pee Wee", were brought in to supplement the "Super Snoop", and the swipe method was abandoned altogether.

Since June the monitoring personnel has expanded from one section (eleven persons) to three sections (forty-one persons) to take care of the M and D problems in the Tech Area and the newly built D.P. Site. Room surveys are now (November, 1945) made daily in sixteen separate buildings (some 300 rooms), using portable instruments (Poppy, Pee Wee, and Zeuto). A "Poppy" used in buildings 51 and 52, D.P. Site (Po building) has a counting range up to 300,000 counts per minute and has eliminated the "infinity" counts,

and the confusion and inaccuracy that accompanies this term. The standard alpha counters now are used (D2, Buildings 1 and 51 at D.P. Site) exclusively for counting nose swabs (already discussed) and air samples. Air samples will be discussed in a later section.

The beta and gamma detecting instruments now in use are the Portable GM Survey Meter, the Beckman Portable Survey Meter and the Landsverk Wollan electroscopes. The actual monitoring of rooms handling beta and gamma emitting radiochemicals is done ordinarily by the Medical Group (A-3), but in emergencies the H.I. Group may be called in to aid in monitoring or decontaminating. The principal beta and gamma radioactive material (RaLa) is used only at Bayo Canyon Site with the exception of a few laboratories in the Tech Area. The GM and L and W meters are used extensively by the H.I. Group in monitoring and decontaminating "W" containers. This M and D procedure will be discussed under a separate section.

(2) Procedures: Rooms and laboratories in buildings D, D annex, D2, D3, Sigma, H, V, U, and M buildings in the Technical Area, and buildings 1, 2, 3, 4, 5, 6, 51, 52 at D.P. Site are monitored daily (Monday through Friday) by "snooping" with the mobile alpha counter "Poppy" or the portable alpha survey meters "Zeuto" and "Pee Wee". Floors, doors, doorknobs, laboratory benches and tables, hoods, exteriors of dry boxes, and other permanent laboratory installations are scanned in these surveys. Locations which yield "over tolerance" counts are labeled as "hot spots" with a tag denoting the actual count.

These "hot spots" should be decontaminated ⁽¹⁷⁾ by the laboratory members

(17)

See Section 9.3-4 (1) on Laboratory Cleaning

as soon as possible. Upon completion of decontamination, an H.I. monitor should be called to check the cleaned area with a Pee Wee or Zeuto. The count must be below tolerance before the decontamination is considered successful.

In cases where the count remains high, even after thorough cleaning, a piece of oil impregnated filter paper is swiped over the surface and held up to the meter. If no counts are recorded by the meter, the active material is regarded as impregnated and further decontamination impossible; usually such positions are covered with paint or stainless steel for the purpose of covering up any contamination that may work out.

In cases in which the laboratory members make no effort to clean the hot positions, a note is sent the Group Leader in charge of that laboratory indicating that this situation exists. In general, there is good cooperation between the laboratory staff and the H.I. monitors, and room contamination has been maintained at a satisfactory minimum.

9.3-3 Preventive Measures in Contamination Control

Operation procedures for the safe processing of radioactive materials are developed in view of the particular and special health hazards inherent in these substances, and all precautions are taken against possible leakage in operating equipment. Nevertheless, during the various processing operations, compounds of these elements do get out of their confining apparatus. Because plutonium and polonium have high specific activities, extremely minute amounts give rise to tolerance values. Thus the small amounts of material that are spread about, even under the conditions of the most careful and exacting laboratory techniques, produce "hot spots".

In the case of polonium only 1×10^{-7} micrograms of the material is necessary to give a count of 500 counts at 50 percent geometry; 7×10^{-3} micrograms of plutonium will give a like counting rate. This indicates that plutonium and polonium compounds or the metal (Pu) should not be handled or processed in any ordinary type of laboratory. Surfaces of wood, chemrock, lead, or porcelain are either porous or semi-porous, and any contamination that falls on these surfaces may "soak in" and become impregnated. Later on, this

contamination may gradually work out and constitute a serious health hazard to all personnel working in that area.

Thus the surfacing of any laboratory involved in processing Pu or Po (also to some extent tuballoy and 25) is of prime importance. A study of various kinds of laboratory surfacing materials shows that the most suitable types for handling radiochemicals, in descending order of effectiveness, are polished stainless steel, polished glass, polished steel and brass, lucite, and certain plastic enamels. Wood, paint, transite, chemrock, stone, cast iron, and linoleum are all semi-porous or tend to become so with use and are unsuitable for surfacing laboratories handling radiochemicals.

Polished stainless steel is of the best surface for contaminated operations as it has a smooth non-porous surface, is easy to clean, is not easily corroded by ordinary chemical reagents and does not ordinarily become rusty, cracked, or porous after extensive use. A very thin layer of light oil applied to the steel surface has been found to be very effective in holding contamination and preventing the active substances from coming into direct contact with the metal. By washing off the oil frequently and applying clean oil the stainless steel surface will remain free of contamination at all times.

9.3-4 Decontamination Procedures

(1) Laboratory cleaning: Laboratory cleaning and decontamination is a matter of good housekeeping. It is the duty of all personnel to keep their laboratory as free of contamination as possible. This is best accomplished by maintaining a well kept and clean room and by cleaning any "hot spots" immediately upon learning of their existence. A "hot spot" left uncleaned will spread and become more and more difficult to decontaminate. The sources of laboratory contamination are many and difficult to control. To aid in decontaminating these "hot spots", several types of cleaning solution have

been developed. Of these solutions, the ones most commonly used are listed and explained in the section of this chapter entitled "Cleaning solutions used."

(2) Floor ~~decontamination~~: Floor contamination has been a big factor in spreading the active material from laboratory to laboratory and throughout the buildings in general. Foot coverings are worn by all personnel in contaminated areas to prevent shoe contamination and the subsequent spreading of material to outside areas as well as to prevent the spreading of contamination to the **hands** and clothing.

Ordinary floor cleaning procedures were found unsatisfactory in keeping contamination to a desirable minimum. Several types of floor oils and waxes were used in an effort to prevent absorption of active materials into the floor coverings and to keep the dust down, but none proved satisfactory. Waxes were found to flake and produce particles small enough to float in the air, carrying the contamination.

Scrubbing machines were found to be very effective in removing contamination from all smooth surface floors. At present all floors are scrubbed every other day with a solution of Tergital or Zoleo. This procedure is effective for both plutonium and polonium.

(3) Contaminated glassware cleaning: The standard laboratory dichromic acid method of washing glassware is used for decontaminating "hot" glassware. The standard cleaning procedure used in the Technical Area is described:

- (a) All glassware from the Chemistry and Metallurgy laboratories is checked with a "Pee Wee" before removal from the laboratories.
- (b) All glassware having counts less than 200 counts per minute (Pu) is considered non-contaminated and must be washed by the

laboratory personnel.

- (c) All glassware having counts greater than 200 counts per minute (Pu) is considered contaminated and is sent to the contaminated glassware washing room.
 - (d) All glassware from the polonium buildings, or glassware in which polonium compounds are handled is automatically considered contaminated, tagged "hot", and sent to the glassware washing room.
 - (e) All glass bottles, etc. must be empty before they are accepted for cleaning.
 - (f) The glassware is first washed in soap and water and rinsed before soaking in the dichromic acid bath. Operators must wear rubber gloves and eye shields during all washing and cleaning operations.
 - (g) Glassware should soak in the acid bath for at least 15 minutes. The dichromic acid is prepared as needed by dissolving five pounds of potassium dichromate in ten gallons of concentrated sulphuric acid. The temperature of the chromic acid should be below 130° F.
 - (h) After soaking in the acid bath, the glassware is first rinsed in tap water, then in 2 per cent sodium citrate solution, and then re-rinsed in tap water.
 - (i) After rinsing, the glassware is dried in a steam heated drier.
- The following should be noted:
- (j) The washing basins and sinks should be surfaced with stainless steel (except the acid bath) to prevent accumulation of active material.
 - (k) Personnel washing the contaminated glassware should wear the

following protective equipment: eyeshields, coveralls and and smocks, shoe covers, head covers or caps, rubber aprons underneath the smocks, heavy acid resisting rubber gloves, and respirators.

(4) Cleaning of "W" containers, apparatus, etc.: Plutonium is brought to this site from Hanford as a slurry of plutonium nitrate in small steel containers termed "W" containers. The container assembly is composed of two parts, an inner stainless steel bomb container and an outer steel carrier. This assembly, during shipment or storage is usually kept inside a boron plastic transfer case. Upon arrival at Site Y the boron case is checked immediately for alpha, beta, or gamma contamination by the H. I. Group to determine if it is safe, from a health standpoint for unloading. If the outside of the boron case is found to be contaminated it must be cleaned before it is handled or unloaded. After being OK'd, the assembly is stored until ready for removal of the plutonium nitrate. Immediately before the containers are delivered to the Purification Group, the container assembly is removed from the boron transfer case, and the inner steel bomb container is taken out of the outer steel carrier. Both the steel carrier and bomb container are carefully monitored for contamination, and any contamination is removed. All counts must be below 50 counts per minute before the container is turned over to the Purification Group. After the Purification Group has emptied the contents, the inner bomb container is returned to the H.I. Group to be rechecked and recleaned. After it is certain all counts on the steel carrier and container are below 50, the assembly is placed back into the boron transfer case and is then ready to be returned to Site "W".

The stainless steel container is very easy to clean. Usually it is only necessary to scrub the steel surface with 2N HNO₃, rinse, and the contamination

is removed. In a few cases it is necessary to repeat the cleaning several times before all counts are below 50. No container has, as of now, been encountered which could not be satisfactorily cleaned.

Other types of laboratory apparatus are decontaminated by the H.I. Group, usually in a special laboratory set aside for this purpose. A general procedure for decontaminating any ordinary item may be outlined:

- (1) Determine the radionuclide producing the contamination ⁽¹⁸⁾

(18)

As Pu and Po, the principal sources of contamination, are handled in separate buildings and areas and are never mixed, it is easy to determine the type of contamination on an item by knowing from which area and building the item came.

- (2) Check with a Poppy and determine the extent of contamination.

- (3) Scrub the items, using the proper cleaning solutions. ⁽¹⁹⁾

(19)

This is left to the discretion of the decontaminator (see section 9.3-4(5) on cleaning solutions.)

- (4) Rinse with distilled water and recheck with Poppy.

- (5) If not below tolerance ⁽²⁰⁾ repeat procedures until below tolerance.

(20)

See Section 9.6

(5) Cleaning solutions used: The principal cleaning solution used for decontaminating laboratory "hot spots" and laboratory equipment contaminated with any or all of the active agents is the Standard Cleaning Solution.

This solution is composed of:

Sodium citrate	5 pounds
Igepal (detergent)	1500 cc
Commercial HCl	250 cc

Distilled water to make up to 20 liters of solution.

Other solutions occasionally used for cleaning equipment or "hot spots" due to plutonium contamination are:

- (a) Citric acid solution (5 per cent)
- (b) Sodium citrate solution (5 per cent)
- (c) Sodium tartrate solution (2 per cent)
- (d) 6 N HCl solution
- (e) 2N HCl solution
- (f) 2N HNO₃ solution

Solutions occasionally used for cleaning polonium contaminated "hot spots" and equipment are:

- (a) 2 N HNO₃ solution
- (b) Sodium hypochlorite solution (2-5 per cent)

Several laundry solutions for laundering protective clothing have been used and each one of variable efficiency and usefulness. The principal laundry solutions are:

- (a) Zoleo solution (2 per cent)
- (b) Igepal solution (2 per cent)
- (c) Ivory soap
- (d) Igepal (2 per cent) and citric acid (3 per cent) solution
- (f) Citric acid solution (5 per cent)

Citric acid solution is extensively used for laundering all protective equipment with beta and gamma contamination (RaLa). Other laundry solutions such as acetic acid and oxalic acid, have been investigated but found either useless or toxic and dangerous to laundry personnel.

Care must be exercised in using these cleaning solutions on the hands or any part of the body for most of the above solutions are strongly acid. The most practical cleaning agent to use directly on the body is a non-alkaline type of soap (for instance sulpho-soap). In cases of extreme body contamination due to Pu a sodium tartrate-tartaric acid mixture has proved to be effective.

9.3-5 Air Monitoring and Air Samples

The hazards connected with air contamination have already been discussed. Preventive measures in effect to maintain low air counts are principally that of dust prevention and control, controlled processing operations which do not allow vaporization, ebullience, diffusion, etc., of active material into the air, and contamination control procedures, such as room surveys, contaminated accident control, etc.

To monitor the degree of air contamination existing in a building, several air filter apparatus have been developed and installed in various strategic points throughout the areas. The Filter Queen air monitoring unit is the apparatus most commonly used and consists simply of an air pump with a special filter paper attachment. Air is pumped through the filter paper at a constant rate of from one to ten cubic feet per minute. It is usually run at 4 cubic feet (113 liters) per minute. After several hours, usually two to eight hours, depending on the probable contamination contained in the air, the filter paper is removed and counted on the "Long Tom".⁽²¹⁾ Counts are calculated by

(21)

See section 9.4-3 (2) (c).

dividing the total counts on the paper by the volume of air (in liters) that passed through the paper. Results are given in c/m/liter of air.

The activity obtained on the filter papers is in part due to the natural radioactivity found in the air. Thus the initial counting rate of the filter paper may be many times that due to polonium or plutonium. Fortunately, however, the natural activity is relatively short lived and a procedure has been developed to permit calculation of the plutonium or polonium activity in the presence of these natural radioactive elements.

Filter Queen units are in use in all contaminated areas and air samples are taken daily. A record of all air counts is kept in the H. I. Group Office. The determination of the concentration of active material in the air that is considered tolerance is complex. At the present time the tolerance for plutonium is 0.035 c/m per liter of air and 0.75 c/m per liter of air for polonium. This is a "two year" tolerance, that is, if a person breathes air containing this concentration of material forty-eight hours a week for two years he will have accumulated a tolerance dose in his body.

Two other types of air filtering equipment have been used. The "Thistle Tube" is made from standard laboratory equipment with a special clamp to hold the filter paper and is attached to the laboratory vacuum line. It has the disadvantage of not being able to draw a sufficient quantity of air in a reasonable period to provide an accurate counting rate. A small mercury manometer is used to measure the air flow. The "Filter King" is a device designed to filter air up to fifty liters per minute. It has been used extensively to test air from contaminated air lines in the Technical Area.

9.3-6 Special Problems

(1) Permeability of rubber gloves to plutonium and polonium: Actual laboratory operations involving the handling of these substances, both in the form of dry metal and dry compounds and wet solutions, gave evidence that most or all types of rubber gloves were either permeable or semi-permeable to these elements.

Studies were conducted in June, 1945, to determine the amount of plutonium or polonium diffusing through rubber gloves. To determine the amount of polonium passing through the rubber, experiments were performed using both wet and dry forms of material, and the permeability determined as a function of time. The results were not conclusive, but there were good indications that the Standard

Latex and Matex gloves were less permeable than other available types.

(2) Contamination in creek water: Several samples of water were taken out of Los Alamos Creek from points extending from the Technical Area to the Rio Grande River, and from Pueblo Creek, north of the Site. Several samples were taken from the Rio Grande River itself. The object of these tests was to determine the amount of plutonium and polonium that was being emptied into these streams through the waste water from the Technical Area and D. P. Site.

Results obtained by analysis of these water samples indicated that the contamination was low and that both elements were rapidly deposited from the water by natural filtration.

(3) Studies on laundry solutions: Efforts are now being made to find better and more efficient laundry washing solutions. Among the cleaning agents being investigated are : citric acid, tartaric acid, acetic acid, oxalic acid, hydrochloric acid, nitric acid, and various types of soap. Rubber gloves have been extremely difficult to decontaminate, and at present rubber gloves are discarded after being worn once because no method of washing has been developed which makes it economically possible to decontaminate them.

9.4 HEALTH INSTRUMENTS

9.4-1 Introduction

All the health instruments have been especially developed for the Manhattan Project. The electroscopes and condenser air chamber methods of radiation detection have been replaced with direct reading electronic instruments to permit rapid surveys and make possible complete surveys over extensive areas or installations. Up to the time of this project, the branch of electronics dealing with very small currents and pulses had not been extensively investigated; since then, extensive study has been made in this field and as a result

new types of tubes and other circuit components necessary to build satisfactory instruments have been developed. This progress has resulted in a number of very satisfactory instruments.

In order to use these instruments intelligently, a knowledge of the types of radiation to be measured is necessary. Alpha, beta, and gamma radiations are the more common types encountered by workers in the CMR Division: in general, the procedures used for monitoring beta contamination also apply to gamma radiations; thus there are only two general monitoring procedures. Alpha particles have very short ranges even in air, so that their detection requires the instruments be placed within a fraction of an inch of the contaminated surface. For this reason it is often difficult to monitor irregular surfaces. Since the particles may be emitted in any one of the 4 pi directions, the instruments must be held close to the surface to detect particles which are emitted at low angles and hence rise only a fraction of their range above the surface. It cannot be stressed too strongly that alpha detection equipment must be placed very close to the active material to secure good qualitative measures of contamination.

While beta and gamma radiations are easier to detect because of their longer ranges, it is more difficult to obtain exact quantitative measurements of "hot spots" because radiations from nearby areas will affect the intensity of the spot being measured. The "hot spot" is best determined by carrying a direct reading instrument and always moving in a direction so that the intensity increases. The "hot spot" is thus located where the maximum intensity is found.

9.4-2 Function of the Instrument Section

The instrument section associated with the Health Instrument Group has the specific duties of keeping all instruments used by the Group in order

and adapting general instruments to special problems. Maintaining the health instruments consists of mechanical and electrical repairs, cleaning the detecting units of contamination and keeping the instruments calibrated. There is very little development of circuits carried on in this section, but there is considerable work done in developing new detectors and making general improvements in the instruments so that less maintenance is necessary. Calibration of the instruments is an important function of this section for with the large number of instruments of various kinds in use, correlation of measurements is possible only by a rigid system of calibration checks. The instrument group has also held the responsibility for instructing monitoring personnel in the proper use of the instruments and interpretation of results. In cases where instruments are assigned to other groups instruction has been given to the personnel involved.

9.4-3 Instruments Used by the CMR Division

The health instruments used in the CMR Division may be conveniently divided into two groups: (a) those used as survey instruments and (b) those used for personnel protection. Both groups of instruments include alpha, beta, and gamma detectors, although the majority of the contamination is alpha emitting material..

(1) Survey instruments:

(a) Portable alpha survey instruments: The instruments in this classification include Pluto, Zeuto, Zeus, and Pee Wee. The Pluto, Zeuto, and Zeus are d.c. amplifiers. In these instruments the ionization produced in the vicinity of an alpha emitting material is collected by means of an electric field and returned to the circuit through a very high value resistor. The voltage produced across such a resistor is measured and taken as an indication of the intensity of radiation. The limit of sensitivity of this type of instrument depends on the characteristics of the amplifier used to measure the produced voltage.

The Pluto was the first instrument of this type and for a long time the only alpha survey meter available for general laboratory use by technicians. The sensitive chamber area of these three instruments is about 100 cm². The full scale sensitivity of the Pluto is about 25,000 c/m, while the Zeto will respond with a full scale reading for about 2,000 c/m. A second range on the Zeto permits a full scale value of 20,000 c/m. The Zeus has a top sensitivity of the same order as the Pluto but it has two more scales of about 100,000 c/m and 2,500,000 c/m full scale. In addition to alpha detection the Zeus can be used for beta and gamma detection. All three of these instruments are sensitive to beta and gamma radiations, however, they are approximately 1000 times less sensitive to these types of radiations than alpha radiations by virtue of the much greater density of ionization produced by the alpha particles.

The Pee Wee is a portable proportional counter. It is essentially an open sided Geiger Muller tube operated in air at atmospheric pressure at such a point on the response characteristic of the tube that the amplification of the pulse in the detector is proportional to the amount of ionization produced by the particles. Operation in the proportional region permits the detection of alpha particles in the presence of beta and gamma radiation. Two ranges are provided on this instrument (2,000 c/m and 20,000 c/m full scale readings.) In addition, earphones can be used for accurate determination of low counts. This is by far the most valuable alpha survey instrument we have at this time.

(b) A.C. operated alpha survey instrument: The Poppy is an A.C. operated instrument having the same general design as the Pee Wee. It is used in locations where considerable monitoring is done and in places where a permanently installed instrument can be used. A loud speaker replaces the earphones of the Pee Wee. This type of instrument is also used as a semi-portable instrument and is mounted on a cart for easy transportation.

(c) Portable beta and gamma survey instruments: The instruments that are included in this group are the Hallicrafter and Victoreen G.M. Survey Meters, Zeus, the Beckman Portable Survey Meter, and the L & W Electrometer.

The unit used to measure beta and gamma radiation is called the "milliroentgen" (mr). The present tolerance is 12.5 mr/hr, indicating that an individual can work in a beta and gamma flux of 12.5 mr/hr 8 hours a day, 6 days a week, for a lifetime, without ill effects. If, however, the radiation flux is higher, the individual should work only a portion of a day so that the total radiation during the day does not exceed the day's tolerance. Hence, in a field of 50 mr/hr, a man should work only two hours per day. This is not a linear function however, and if personnel are required to work in above tolerance areas the H.I. Group should be contacted and the permissible time limit set by their representative.

The Zeus and Beckman Portable Survey Meter are d.c. amplifiers and have the same limitations as the d.c. amplifiers mentioned under alpha detectors. Both of these instruments are equipped with a thin walled chamber (thin enough to allow most beta rays to enter, but thick enough to stop alpha particles) and a slide to cover the chamber with thicker material which will absorb a large part of the beta radiation. The Beckman Portable has the following full scale values for various ranges: 20, 80, 400, and 2000 mr/hr. The Zeus has the following ranges: 25, 100, and 2500 mr/hr.

The L & W Electrometer is a portable instrument in which the ionization produced by radiation discharges the voltage on the electrometer needle; comparison of the time necessary to discharge the fiber with a calibration chart allows determination of the radioactivity. The L & W Electrometer has a built-in timing light so calibrated that the movement of the needle across the scale between light flashes indicates the rate of radiation directly

in scale readings. A sliding metal cover permits measurement of beta and gamma or gamma radiation. The meter has two ranges, 100 mr/hr and 2000 mr/hr full scale values.

The portable GM survey meters, made by the Victoreen Instrument Company and the Hallicrafter Company, are conventional G.M. tubes with pulse integrating circuits. The Hallicrafter unit provides the high voltage necessary for operation of the G.M. tube by an electronic multivibrator circuit, while the Victoreen unit uses a special battery to furnish the G.M. tube voltage. Since the G.M. tube detects individual beta and gamma rays, these instruments can be made very sensitive. The Hallicrafter unit has two ranges: 0.12 and 2.5 mr/hr full scale. Cosmic ray backgrounds may give a 10-30 per cent reading on the most sensitive scale. The Victoreen instrument has three ranges: 0.2, 2.0, and 20 mr/hr full scale. Both instruments have sliding covers to allow either gamma or beta and gamma detection. In the Hallicrafter unit the GM detector is located within the instrument box, whereas the detector of the Victoreen unit is attached to a short cable. In addition to the greater flexibility gained in survey work by having the G.M. tube on a cable, the Victoreen unit can also be used for detecting low intensity radiation by attaching earphones to the unit.

(2) Instruments used for personnel protection:

(a) Alpha hand counting instruments: Although d.c. amplifiers and chambers were first used for checking hand contamination, the methane proportional counter was the first instrument to give reliable quantitative results. In this instrument a fine central wire G.M. tube was operated in the proportional region in methane at atmospheric pressure. A very thin

window of collodion permitted alpha particles to enter the chamber but kept air from mixing with the methane. Methane was used because of its low ionization potential which resulted in a large initial pulse to the amplifier and made it possible to use a simple amplifier.

Later the Chicago Hand Counter was developed and has since proved to be a very satisfactory instrument. The methane has been dispensed with and a more sensitive amplifier developed to use the smaller pulse. A logarithmic integrating unit has been incorporated to give good percentage accuracy to the reading over a very wide range of values. These instruments are installed in numerous spots so that all workers in the laboratories have easy access to a hand monitor. The detector unit used with the Chicago instrument can be made in almost any size so the probes used at present are large enough to allow complete coverage of the entire side of a hand. If the probes are used in pairs it is possible to monitor an entire hand, front and back, at a single operation. The probe units for the Chicago Hand Counters were easy to obtain so some of the amplifiers used with the methane filled detectors were modified to provide better instruments for special monitoring purposes.

(b) Beta and gamma instruments: Only two instruments belong to this group; the Victoreen pocket chamber and the L & W pocket electroscope. The Victoreen pocket chamber which is an air condenser with almost perfect insulators used as supports. Before entering a working area the chambers are charged to a given voltage; at the end of the working period the voltage remaining on the condenser is measured by an electrometer and the voltage is taken as a measure of the radiation received by the worker.

The L & W pocket electroscope operates on the same principle except that a small electroscope is built into the unit so that the discharge can be

measured at any time by looking through the meter and reading the enclosed scale.

(c) Monitors for air contamination: Since many of the materials encountered in these laboratories are handled in the dry or powder forms it is very likely that active dust is spread by air currents. Thus in order to monitor the amount of active material in the air, the air in various sections of the laboratory is pumped through fine filter paper and checked for active material. A portable air pump (Filter Queen) and a tubular piece of special high retention filter paper is used to collect the dust. A special counter known as the "Long Tom" is used to determine the activity. This counter is simply a standard alpha counting instrument with the chamber adapted to receiving the tubular sample. The samples are collected over a period of several hours so that an integrated value is obtained.

9.5 HEALTH RECORDS

Permanent records kept by the H. I. Group are as follows:

- (1) Daily monitoring survey results (both before and after decontamination).
- (2) Air monitoring results.
- (3) Hand count results.
- (4) Nose count results.
- (5) Urinalysis and health pass data.
- (6) Special decontamination data.
- (7) Contaminated accident data.
- (8) Monthly laboratory survey results.
- (9) Group hazard reports.
- (10) Individual exposure data.
- (11) Contaminated operation data (outside services).

With the exception of (6), copies of all records are sent to the Medical Group for incorporation into individual case histories.

The above records have a two-fold purpose. One, they provide the Health Group with data that can be correlated and used to improve methods of health protection. Two, they provide a permanent record of all procedures for individual and group health protection in case any future legal action may require the use of such records.

9.6 RADIATION LIMITS

Radiation or Material	Hands c/m	Nose c/m	Body (Surface)	Body (Internal)	Boots c/m	Clothes c/m	Gloves c/m	Respirators c/m	Urine c/m/24hr	Air Tolerance
Alpha (α)	-----	-----	†† 1.25 mrep/hr	-----	---	---	---	---	---	---
Beta (β)	-----	-----	12.5 mrep/hr	-----	1.25 mrep/hr	1.25 mrep/hr	1.25 mrep/hr	1.25 mrep/hr	---	---
Gamma (γ)	-----	-----	12.5 mrep/hr	-----	1.25 mrep/hr	1.25 mrep/hr	1.25 mrep/hr	1.25 mrep/hr	---	---
(Note)	250	†50	1.25 (α) mrep/hr	1 μ g	1500	500	250	Total 100(inside) 200(outside)	7	0.0175 c/m/L (*)
(Note)	1000	†500	1.25 (α) mrep/hr	6×10^{-4} μ g	6000	2000	1000	Total 500(inside) 1000(outside)	1500	0.75c/m/L (*)
(Note)	One hour contact	-----	12.5 (β) mrep/hr	Very low toxicity by ingestion	Alpha limit same as for 49			See Sec. 9.2-2 (b)		150 μ g (**) per cu. ft.
(Note)	One hour contact	-----	12.5 (β) mrep/hr	Very low toxicity by ingestion	Alpha limit same as for 49			See Sec. 9.2-2 (b)		150 μ g (**) per cu. ft.
	-----	-----	12.5 (γ) mrep/hr	0.1 μ g (α)	---	---	---	---	---	2.5 μ g 10^{-6} μ g/L

(*) Two year tolerance assuming 100% retention by lungs (actual value depends on fraction retained).

(**) Chemical toxic tolerance

(†) If both nostril counts are above 50 c/m (49), 500 c/m (Po), the lower value is taken as the high nose count.

(††) mrep/hr -- milliroentgen equivalent physical per hour (12.5 mrep/hr is tolerance for β and γ , 1.25 mrep/hr for α).

Note: The limits set by the laundry are based on the following figures,

A. 49

- 1) Boots - 30 c/m/in²
- 2) Clothes - 10 c/m/in²
- 3) Gloves - 10 c/m/in² (same as hands)
- 4) Respirators - 5 c/m/in² (inside), 10 c/m/in² (outside)

- B. Po limits are, with the exception of respirators, four times those of 49; respirators are five times.

9.7 HEALTH SAFETY RULES

The following list of rules is in effect in the CMR Division at the time of writing. Any exception to it must be by agreement with the group requesting such exception and the authorized representatives of the H.I. and Medical Groups.

1. Cleaning rags and other contaminated trash should be disposed of in special trash containers marked with red paint.
2. Booties, coveralls, smocks, surgeon's caps, rubber gloves, and respirators must be worn at all times when working with 49 or Po. Face shields must be worn in all operations involving handling of boiling solutions, or other solutions in which there is any possibility of a spray being formed.
3. Coveralls and respirators must be worn in handling tuballoy or 25 where there is any possibility of either material getting into the air. In machining either of these metals, a solution of water soluble oil must be kept playing on the portion being machined. Direct handling of these metals should be kept at a minimum. During operations involving direct handling of these materials for more than one hour per day, thick, protective gloves must be worn.
4. When leaving a building where contaminated operations are carried on: smocks, booties, caps, gloves, and respirators must be removed, (gloves should be left in the working area within the building). Project issued coveralls are not to be worn when leaving the technical or D.P. areas or when entering non-contaminated buildings within these areas, except the dispensing sections of K and S stock. Spot checks will be made to see that this rule is followed.

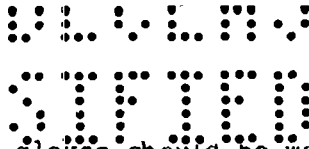

5. All rubber gloves should be washed frequently in the approved manner during long operations and before removing from hands. Hands should be carefully washed after removal of gloves and checked under the alpha hand counter.
6. No mouth pipetting shall be done in any operation in which active materials are involved.
7. No material either free or in working containers, and no contaminated objects shall be set on writing desk tops. Exhibition specimens kept in cleaned, closed containers are exempt from this rule.
8. Persons desiring to work with the material in laboratories other than their own, must request permission from the usual occupants before beginning the work.
9. All active dust producing operations must be done in approved dryboxes or sealed vacuum systems.
10. Fans should be left running in all hoods which contain or have contained active material until they have been checked and decontaminated to the satisfaction of the H. I. Group.
11. a) In case of any spills involving active material, personnel not required for recovery should leave the laboratory immediately and the remaining personnel as soon as possible. All fans not already operating should be turned on before leaving. The H.I. Group should be notified as quickly as possible after any such accidents.
- b) In case of an accident in which active material may have been introduced into a wound, the following procedure should be followed:

- (1) Wash wound immediately with full stream of tap water.
- (2) Squeeze wound or apply tourniquet to increase bleeding.

U. S. 40

- (3) Report to Post Hospital for treatment of wound as soon as contaminated clothes have been changed.
- (4) Inform the receptionist at the Hospital that this is a "Technical Area Emergency"; be careful to confide the nature of the accident only to the doctor in charge.
- (5) Report the accident to both the P.I. and Medical offices after the wound has been treated.

12. No eating, drinking, or smoking will be allowed in rooms so posted. No food or drink is to be kept in laboratory refrigerators.

13. The following M & D procedures are in effect:

- a) Daily room surveys are made and all "hot spots" (greater than 500 c/m) are indicated by a suitable marker.
- b) As soon as possible the laboratory personnel should decontaminate the "hot spots" found.
- c) Upon the completion of decontamination, if no member of M & D is present, the H. I. Group should be called to monitor the cleaned area in order to determine whether it is below 500 c/m.
- d) If any persistent count within a room is 5000 c/m (49,25, and tuballoy) and 10,000 c/m (Po), or greater, all operation will be stopped within that room until it has been cleaned. The cleaning will be done by the room occupants with the assistance of an H. I. representative, if desired (Section 13c applies after such cleaning).

Rule 13 does not apply in case of emergency or contaminated accidents. In such cases all M & D services that are necessary and available will be supplied. It should be noted that in the event of serious accidents or spillage the room count

~~SECRET~~

is to be assumed to be above 5000 C. m (for 49,25 and tuballoy). and 10,000 c/m (for Po), or greater, until shown otherwise.

UNCLASSIFIED

References:

LA-391, Chemistry and Metallurgy Health Handbook of Radioactive Materials.

LA Technical Series:

Vol. 1, Chapter 5, Radiation Health Monitoring

Vol. X, Chapter 6, Physiological Aspects of Polonium Handling

Scientific and Technical personnel in CMR-12 contributing to the work described in Chapter 9.

P. Alpine	R. Dumrose	V. Mertes	M. Rischall
F. Appler	G. Dunlap	E. Molloy	N. Roth
C. Beck	V. Foley	E. Mueller	R. Rupert
C. Brown	L. Gilbert	F. Mullins	A. Serna
I. Brown	D. Greening	H. Nelson	E. Thayer
N. Coble	H. Hadley	C. Numerof	J. Tribby
E. Cole	W. Hinch	H. Pence	W. Uebel
S. Cowling	N. Idenden	C. Peterson	S. Valdez
W. Cox	R. Kaufmann	J. Peterson	O. Wagner
J. Davidson	G. Lagomarsini	G. Ponton	H. Ward
M. Decker	R. Maas	C. Price	N. Wells
C. Derrickson	J. Maxim	C. Rendell	E. Unkealy
J. Dumanian	M. McCallen	D. Reynolds	J. Wilson

G. Young

UNCLASSIFIED

~~SECRET~~

081130
031712

DOCUMENT ROOM

REC. FROM R.R. Davis

DATE 7/1/47

REC. NO. REC.

031712
081130