

*photoconductivity and*

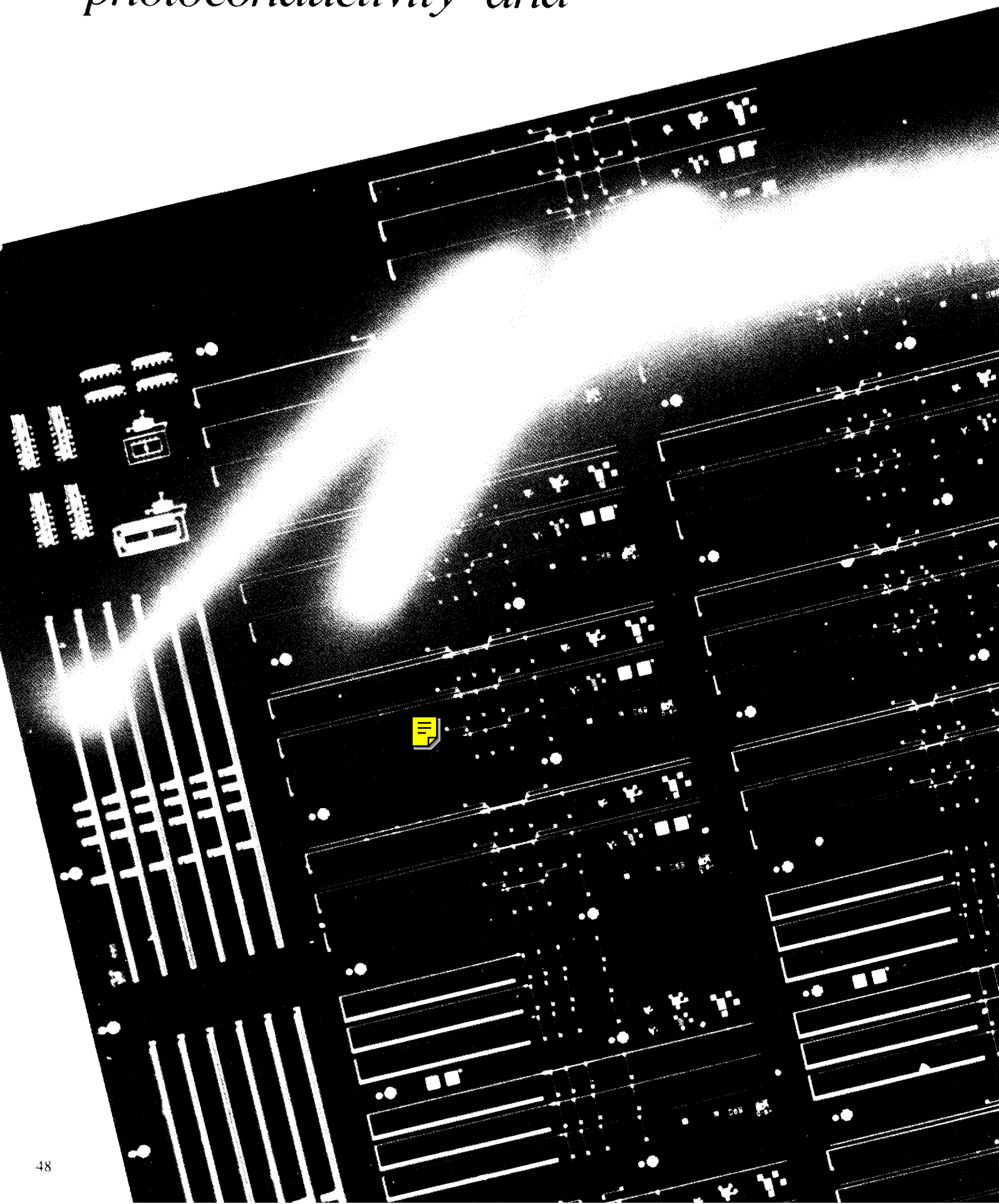

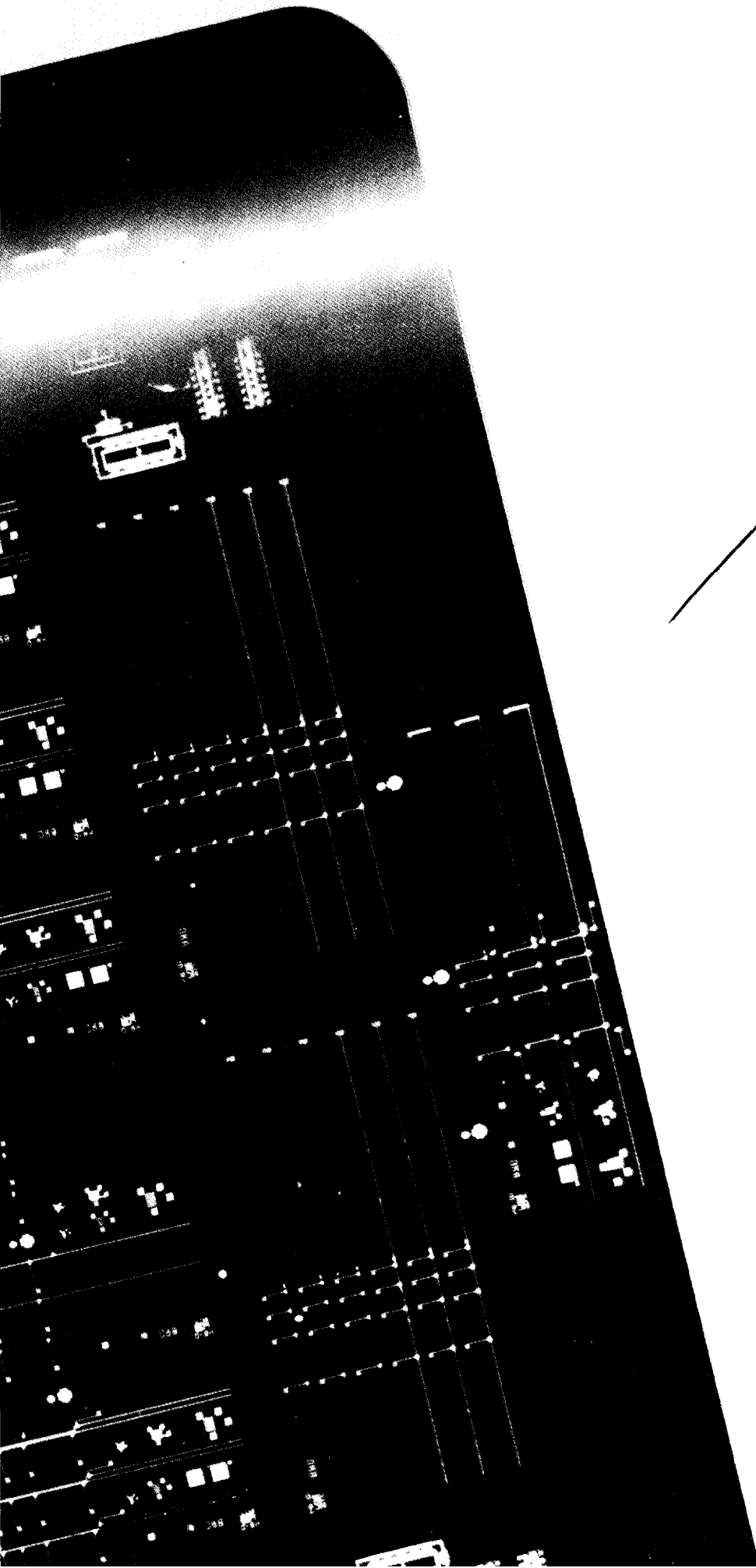

*by Robert B. Hammond*

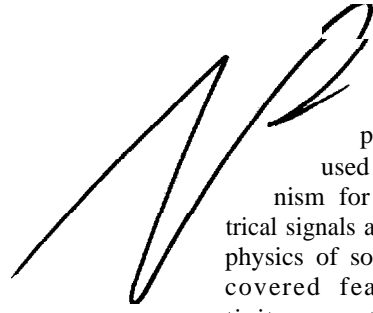

Photoconductivity is by no means an unheard-of phenomenon, having been used for decades as a mechanism for converting light to electrical signals and as a tool for studying the physics of solids. But two recently discovered features of photoconductivity—an extraordinarily rapid onset and, in some materials, a similarly rapid decay—have made it the basis for a new class of electronic devices with exciting applications in diverse areas of research and technology.

The Electronics Division at Los Alamos is a leader in developing the new photoconductive devices. We have demonstrated switches for initiating near billion-watt pulses of electric power in less than a nanosecond ( $10^{-9}$  second), detectors for tracking the rapidly varying radiation from fission and fusion reactions, and instruments for studying the behavior of integrated-circuit components during intervals as short as a picosecond ( $10^{-12}$  second). Before describing these devices and their applications in detail, a brief review of the history and phenomenology of photoconductivity itself is in order.

**A portion of a silicon integrated circuit used in measurements of the velocity, attenuation, and dispersion of high-frequency electrical signals as they propagate along various microstrip transmission lines. Photoconductive pulse generators and sampling gates fabricated within the integrated circuit permit such measurements to be made at frequencies previously inaccessible and with unprecedented accuracy.**

As its name suggests, photoconductivity is an increase in the electrical conductivity of a material when it is illuminated by photons or other forms of radiation, such as electrons or alpha particles. The effect was first observed in 1873 in selenium and was soon incorporated in an 1884 patent for a precursor of a television camera. Initially thought to be a rarity, photoconductivity has now been observed in so many materials that it is assumed to occur in nearly all solids, whether nonmetallic or metallic, amorphous or crystalline. In some materials the conductivity increase is large and varies linearly (or nearly so) with light intensity. These materials find practical application in such familiar devices as photographic exposure meters, xerographic copiers, and vidicon television cameras.

With the formulation of the band theory of electronic states in crystals came an explanation for photoconductivity. As illustrated in Fig. 1, photons with appropriate energy excite electrons across the band gap (forbidden energy region) separating the valence band (the highest filled energy band) and the conduction band (the next higher energy band). Since the conduction band offers many unoccupied, very closely spaced energy levels, electrons in that band are free to acquire momentum and energy from an electric field and thus act as current carriers. (The same mechanism, triggered by thermal energy rather than incident radiation, is responsible for the modest conductivity of pure semiconductors and the very low but finite conductivity of pure insulators at temperatures above absolute zero.) Excitation of electrons to the conduction band creates holes (unoccupied energy levels) near the top of the valence band. These holes also contribute to the photocurrent, acting in effect as carriers of positive charge. As one might expect, the photoconductivity of semiconductors and insulators is quite pronounced, whereas that of metals is but a small fraction of their very high inherent conductivity.

The minimum energy required to create

an electron-hole pair in a perfect crystal equals the width of the band gap, which is about 1 eV (electron volt) for the semiconductor silicon and about 6 eV for the insulator diamond. (These energies correspond respectively to near-infrared and ultraviolet photons.) However, the defects present in all real crystals, such as lattice vacancies or substitutional impurities, decrease the energy necessary for excitation by creating allowed energy levels within the band gap. Information about the energies of such levels can be deduced from measurements of photoconductivity as a function of photon energy. Photoconductivity has thus proved a valuable tool for research in solid-state physics.

Not until 1975, more than a century after its discovery, was the ultrafast onset of photoconductivity demonstrated, by D. H. Auston of Bell Laboratories. The long delay was not due to oversight. Rather, this feature was simply not observable before the development, in the late sixties and early seventies, of lasers capable of producing very short pulses of light. Auston measured the rise time of the voltage pulse generated across a high-purity, crystalline silicon sample by a 5-picosecond pulse of laser light. The results implied a rise time for the photoconductivity of less than 10 picosecond. Five Years later Auston and his coworkers determined a fall time of about 5 picosecond for the photoconductivity in a sample of amorphous silicon.

A short rise time is an inherent characteristic of photoconductivity and was suspected long before being demonstrated experimentally. The creation of electron-hole pairs is virtually an instantaneous process and occurs throughout the volume of material illuminated within the very short time required for light to reach its optical absorption depth, or maximum depth of penetration. (For an optical absorption depth of 1 micrometer, a fairly typical value, the penetration time is about 10 femtoseconds, or 0.01 picosecond.) Thus almost no delay need be involved in establishing a conductive path

across a photoconductor. In contrast, the introduction of carriers into a conventional semiconductor device (such as a transistor or diode) is localized at junctions between *p*- and *n*-type regions, and establishing a conductive path across the device involves a relatively slow process, the physical transport of carriers under the influence of an applied voltage (the bias voltage).

The decay of photoconductivity with cessation or decrease of illumination is not inherently rapid since the 'death' of carriers, unlike their creation, is far from instantaneous. (Still, however, no carrier-transport time is involved.) The number of carriers decreases with time by a process known as recombination, the mutual annihilation of an electron and a hole. The time required for the number of carriers to decrease by a factor of *e* is called the carrier lifetime. This parameter is usually determined by the number and nature of defects in the material, which determine the number and energies of levels within the band gap.

The lifetime of carriers in a crystalline material usually increases with crystal perfection. Carrier lifetimes in common high-purity, crystalline semiconductors are typically on the order of nanoseconds to milliseconds but can be decreased by introducing defects or impurities into the lattice, although often at the expense of other desirable properties.

Demonstration of the fast onset and the potential for fast decay of photoconductivity piqued the interest of many who saw the need for better methods of rapidly initiating electrical signals or of tracking rapidly varying radiation or electrical signals. New photoconductive devices are now helping to fill that need, which arises in activities as disparate as accelerating particles, testing nuclear weapons, and investigating nonequilibrium transport phenomena in semiconductors. The new devices described below are those developed at Los Alamos, some in collaboration with other institutions, and by no means exhaust the possibilities.

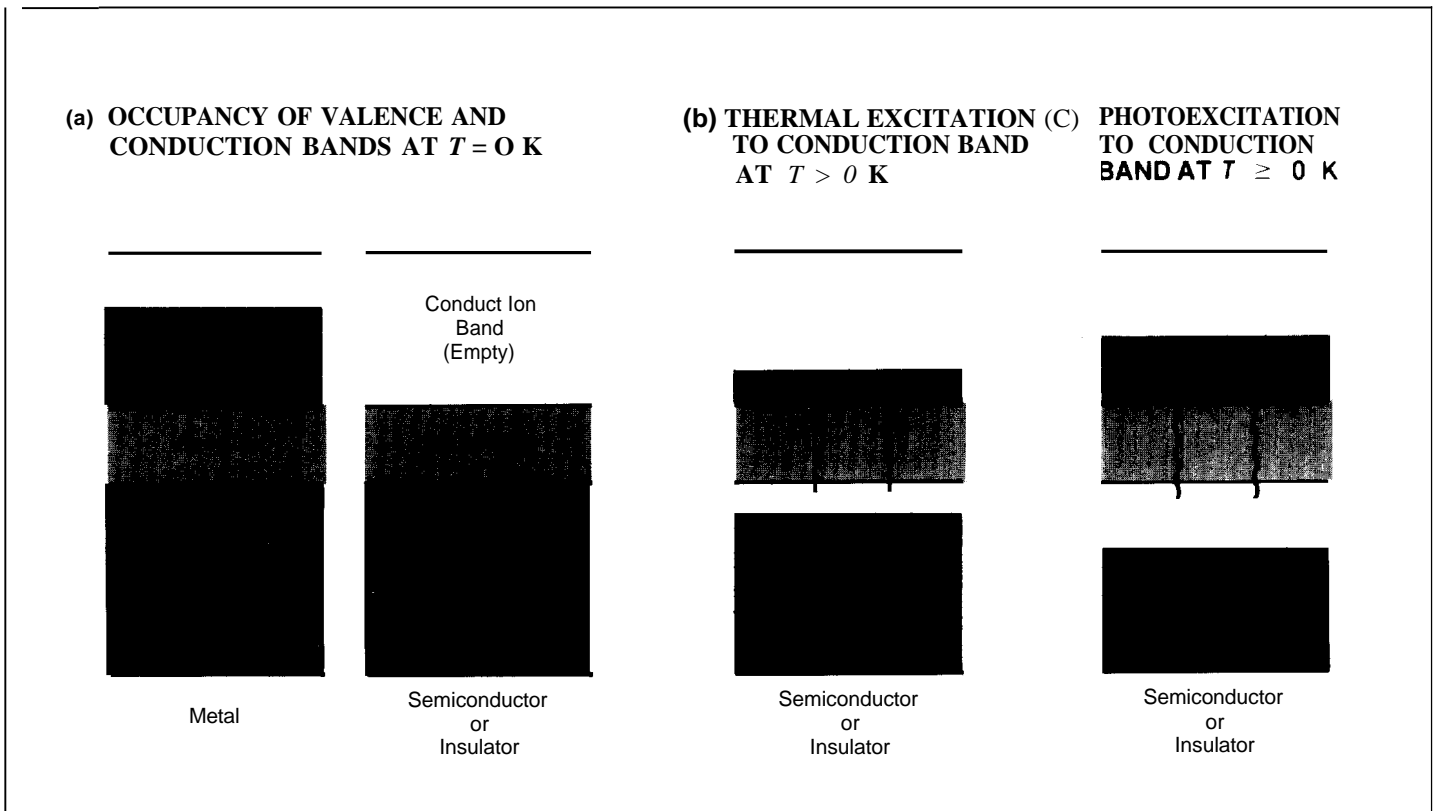

Fig. 1. The band theory of electronic energy levels in solids provides an explanation for electrical conductivity in general and for photoconductivity in particular. According to that theory the energy-level structure consists of bands of very closely spaced allowed energies (hatched regions) separated by gaps of forbidden energies (dark gray regions). The intrinsic electrical conductivity of a crystalline material depends on the occupancy of the uppermost bands, which in turn depends on the electronic configuration of the atoms constituting the material and on the structure of the crystal. Shown in (a) are the two possibilities for the occupancy of the uppermost bands in a crystalline material at absolute zero. In one case the highest nonempty band is only partially occupied, as indicated by red (occupied) and white (unoccupied) regions. Available to the electrons within this conduction band are many

unoccupied levels of only slightly higher energy and momentum. A modest electric field can cause transitions to those levels, thereby creating a net momentum and a flow of current. Such a material is called a metal. In the other case the highest nonempty band is fully occupied, and the nearest levels available to the electrons within this valence band lie above the band gap in the conduction band. A modest electric field cannot supply the energy necessary to bridge the band gap, and no current flows. Such a material is called a semiconductor or an insulator depending on the width of the band gap. (b) The conductivity of semiconductors and insulators at temperatures greater than absolute zero is low but nonzero since some electrons possess sufficient thermal energy to bridge the band gap. This thermal excitation accounts for the strong temperature dependence of the conductivity of semiconductors and in-

ulators. (c) Photons and other forms of radiation can also supply the energy necessary to bridge the band gap and cause the increase in conductivity known as photoconductivity. The effect is illustrated for semiconductors and insulators, which exhibit a much greater relative increase in conductivity than do metals. The photoconductivity of many materials is directly proportional to the intensity of the incident light. Note that unoccupied energy levels, or holes, are created near the top of the valence band when electrons are excited to the conduction band, whether by thermal energy or photons. Occupation of these holes makes a contribution to the current, a contribution identical to that expected of carriers with positive charge. The energy-level structures depicted are simplified in the sense that the band gap is completely devoid of allowed energy levels, a situation that obtains only in the ideal of a perfect crystal.

## Ultrafast Photoconductor Power Switch

By the late seventies a number of researchers had used the combination of a photoconductor and a pulsed laser to generate electrical pulses with very short rise times. Currents up to 100 amperes at voltages up to 10 kilovolts were reported. Some back-of-the-envelope calculations on our part indicated that much higher currents at much higher voltages might be attained, without sacrificing short rise times, simply by increasing the dimensions of the photoconductive volume. This finding led naturally to the idea of a photoconductor power switch, a device for producing high-power, short-rise-time, accurately timed pulses of electricity. Other hopes for the switch included relatively long duration of the output pulses and economy of operation.

The photoconductor power switch is basically very simple in design (Fig. 2). It consists of a pulsed laser and a small volume of photoconductive material connected to a source of voltage (the operating voltage) and to the load. The electrical connections to the voltage source and the load should have a high injection efficiency; that is, they should permit efficient replacement of the electrons swept out of the photoconductor during its on state. To help realize a short rise time and also prevent energy loss due to electromagnetic radiation, the photoconductor should be incorporated in a transmission line (for example, a coaxial or microstrip transmission line).

For our proof-of-principle experiments we chose the combination of a neodymium-glass laser and very pure, crystalline silicon. A Nd:glass laser is readily available and inexpensive and can be operated to produce high-intensity optical pulses. A semiconductor is preferable to an insulator as the photoconductive material because electron-hole pairs can be created in a semiconductor by the infrared photons from the Nd:glass laser, and yet the dark resistivity of a semiconductor is

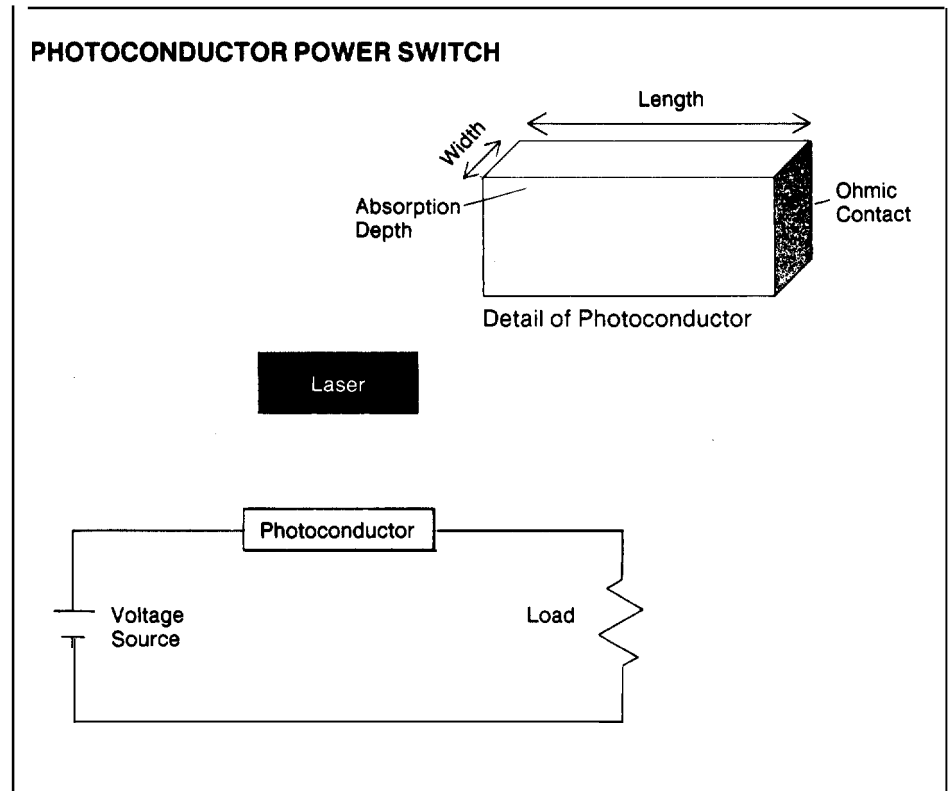

**Fig. 2.** A small volume of photoconductive material of relatively high intrinsic resistivity, a high-voltage source, and a pulsed laser are the basic components of a photoconductor power switch. When the photoconductive material is illuminated by a pulse of photons from the laser, its conductance rapidly increases and a short-rise-time current pulse flows through the load. In the absence of a laser pulse, the photoconductive material acts in effect as an open switch. The ohmic contacts to the

photoconductive material permit efficient replacement of the carriers swept out of the active volume during its conducting state. In practice the photoconductive material is incorporated into a coaxial transmission line to help achieve a short rise time and to prevent energy loss due to electromagnetic radiation. As discussed in the text, the power capacity of the switch can be increased simply by increasing the length and width of the photoconductive material.

sufficiently high that the current through the switch in its off state would be very low. The choice between two strong candidates for the semiconductor, gallium arsenide and silicon, was based on consideration of the properties listed in the accompanying table. Gallium arsenide offered the advantages of higher dark resistivity and higher carrier mobility. Higher carrier mobility implies higher carrier velocity for a given operating voltage,

which in turn implies higher current per carrier. We chose silicon rather than gallium arsenide, however, because of its greater absorption depth for the 1.06-micrometer photons from the Nd:glass laser and, most important, its longer carrier lifetime. A greater absorption depth permits excitation of a larger cross-sectional area and thus generation of higher currents. A longer carrier lifetime is an economic advantage, permitting produc-

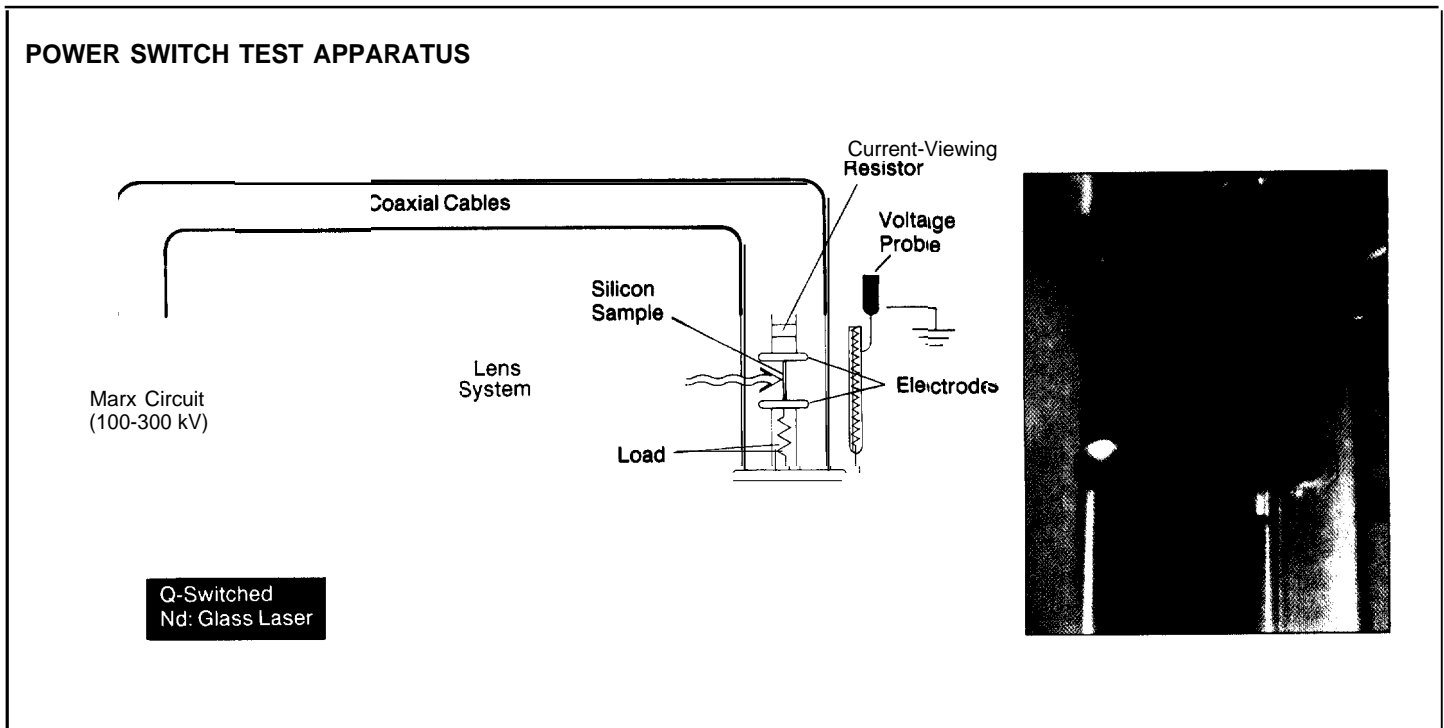

Fig. 3. The performance of high-resistivity, crystalline silicon in a photoconductor power switch was evaluated with an apparatus including a Marx circuit for supplying the operating voltage, a low-inductance current-viewing resistor for measuring the current through the switch, and a capacitance-

compensated voltage divider for measuring the voltage across the load. The impedance of the load, a copper sulfate solution, was adjusted to match that of the coaxial cables. Good electrical contact between the silicon sample and two brass electrodes was ensured by a spring arrangement. The

entire test assembly at the end of the coaxial cables was immersed in a dielectric fluid to prevent high-voltage arcs between circuit points. The photograph shows a portion of the apparatus, including the silicon sample, the brass electrodes, and the copper sulfate load solution.

### Table

The choice of photoconductive material for a particular application is usually a compromise based on a number of properties. Listed below for silicon and gallium arsenide are properties of importance to a photoconductor power switch activated by 1.06-micrometer photons from a Nd:glass laser. An absorption depth for gallium arsenide is not listed because 1.06-micrometer photons are not sufficiently energetic to excite carriers to the conduction band in pure gallium arsenide. Thus the absorption depth is extrinsic, varying from sample to sample with the concentration of impurities or defects.

Property	Silicon	Gallium Arsenide
Carrier mobility	1925 cm <sup>2</sup> /V · s	9300 cm <sup>2</sup> /V · s
Carrier lifetime	1 ns to 1 ms	0.1 to a few ns
Intrinsic resistivity at 300 K	0.23 MΩ · cm	100 MΩ · cm
Absorption depth for 1.06-μm photons	1 mm	---

tion of a satisfactorily square current pulse for a longer time without repeated excitation by the laser.

What physical and material properties determine the power capacity (the operating voltage and current) of a silicon power switch? Although the voltage gradient across the silicon during its off state must not exceed its dielectric strength (about 100 kilovolts per centimeter), the operating voltage can be increased simply by increasing the length of the photoconductive volume (the distance between the contacts). Similarly, although the carrier density in the silicon must not exceed about 10<sup>18</sup> per cubic centimeter (or, equivalently, the current density (at room tem-

perature in an electric field of 1 kilovolt per centimeter) must not exceed about 300 kiloamperes per square centimeter), the current through the silicon can be increased simply by increasing the cross-sectional area of the photoconductive volume. Since the depth of the cross-sectional area is fixed at the optical absorption depth of silicon, the width is the dimension varied to accommodate a desired operating current. This ease of scaling to arbitrary power capacities is due to the bulk nature of photoconductivity.

The limit on the carrier density in silicon, and ones of similar magnitude for other semiconductors, is necessary to minimize two phenomena that would adversely affect the performance of the switch. At carrier densities above  $10^{18}$  per cubic centimeter, the rate of Auger recombination and the magnitude of free-carrier absorption increase rapidly. Auger recombination decreases the fall time of the photoconductivity and thus the duration of the current pulse: absorption of laser light by free carriers produces no additional carriers and thus wastes laser energy.

The rise time of the current pulse is determined by two factors: the inherent rise time of the photoconductivity and the inductance of the circuit. The low inductance necessary for a short rise time can usually be achieved by increasing the width of the photoconductive material. Therefore high currents and fast rise times are compatible goals.

Although some applications envisioned for the photoconductor power switch require only isolated current pulses, others require a periodic sequence of pulses. The rate at which the pulses can be repeated is limited to between about 10 and 1000 times per second. This limit is necessary to avoid thermal runaway, a mounting cycle of resistive heating, increased thermal generation of carriers, increased current, increased resistive heating, and so on, that culminates in complete conduction and melting of the switch. Were it not for the high specific heat and thermal conduc-

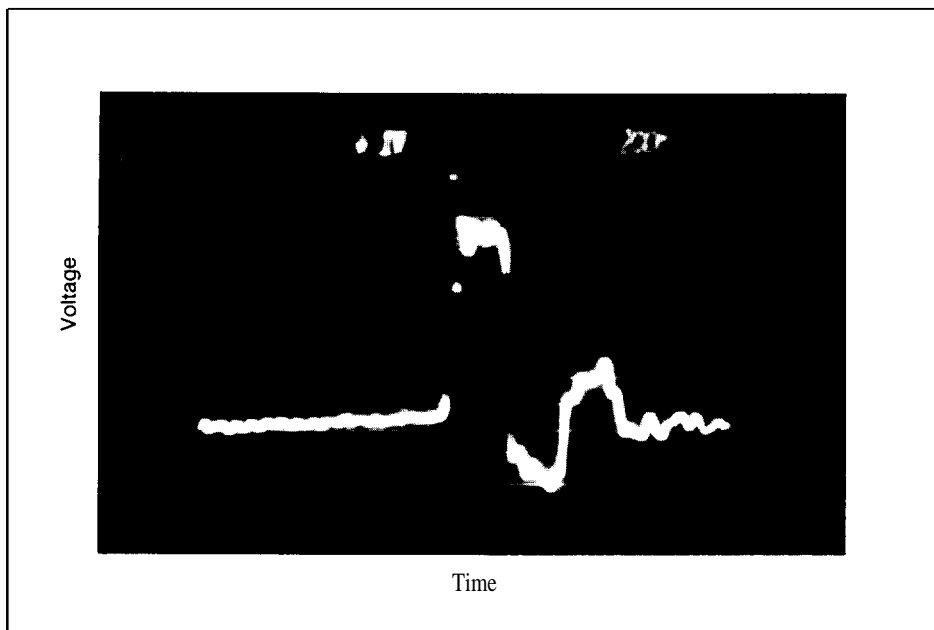

**Fig. 4.** Oscilloscope trace of a current pulse generated by a 0.5- by 0.5- by 2.5-centimeter bar of high-resistivity silicon in the apparatus of Fig. 3. The current pulse was induced by a 10-millijoule, 20-nanosecond laser pulse. Note the rapid

rise of the current to its peak value of about 1.8 kiloamperes. This current, at the operating voltage of 170 kilovolts, corresponds to a switched power of about 150 megawatts. The duration of the pulse is about 200 nanoseconds.

tivity of silicon, the limit on the repetition rate would be even lower,

We tested a number of switches, using the apparatus shown in Fig. 3, and the results confirmed our expectations for the potential of the device. For example, with one switch fashioned from a 2.5-by 0.5-by 0.5-centimeter bar of 1000-ohm-centimeter silicon and illuminated by a 20-nanosecond (full width at half maximum) laser pulse, we obtained a peak switched current of about 1.8 kiloamperes at an operating voltage of about 170 kilovolts (Fig. 4). These values for the current and voltage correspond to a peak switched power of about 150 megawatts. The rise time of the current pulse was approximately 5 nanoseconds; its duration was about 200 nanoseconds.

Our tests revealed nothing to prevent operation of a photoconductor power switch at voltages and currents approaching the maxima imposed by the

limits on voltage gradient and carrier density mentioned above.

The major advantages of the photoconductor power switch over present high-power switching technologies are greater ease of scaling, output pulses with much shorter rise times, and independent optical control. Independent control eliminates interference from the switching circuit itself, and optical control permits greatly increased accuracy in the timing of a succession of pulses from one switch or of a temporal sequence of pulses from an array of switches. Other advantages include small size, simplicity, and efficiency at transforming optical energy to electrical energy. (The test switch mentioned above, which received an incident laser energy of 10 millijoules, transferred about 30 joules to the load.) The overall efficiency of the device is limited, however, by the inefficient production of optical energy by the lasers now commercially available. That

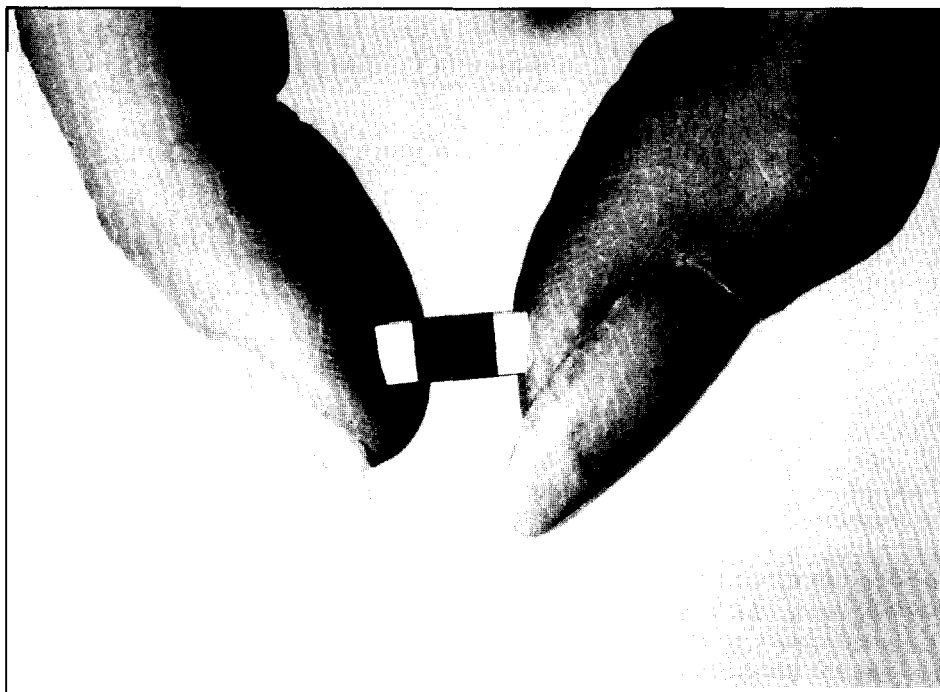

**Fig. 5. One of the great advantages of a photoconductor radiation detector is the size of the active volume, which is many times smaller than that of other**

**detectors with comparable sensitivity. The photograph shows the active volume of one of the larger of our InP:Fe detectors.**

fault will soon be remedied since Nd:YAG (yttrium aluminum garnet) lasers with efficiencies up to 40 percent have recently been demonstrated.

Among the possible applications of photoconductor power switches are many systems that require high-power, short-rise-time, accurately timed pulses of relatively short duration (less than about 1 microsecond) at relatively low repetition rates (less than a few hundred per second). Such systems include particle accelerators, lasers for initiating thermonuclear fusion, devices for simulating nuclear-weapons effects, and directed-energy weapons.

Applications requiring longer pulses must await development of efficient methods for maintaining the carrier density at the desired level. One promising approach is to initiate the electrical pulse with a laser pulse and to maintain the carrier density with a beam of electrons. (We have shown

crate carriers in a photoconductor.) This approach may find applications in systems for producing ac power. Potential uses extend from very-low-voltage systems, systems in which the output voltage is less than the typical  $p-n$  junction drop (about 0.5 volt), to the very high-voltage systems that condition electrical power for long-distance transmission.

### **Ultrafast Photoconductor Radiation Detector**

Assessing the results of, say, a laser-fusion experiment or a nuclear-weapon test involves diagnostic measurements on very unusual radiation **events**, events in which the intensity of the radiation varies extremely rapidly over an extremely wide range. Those measurements require equally unusual radiation detectors, detectors with ultra-

stant sensitivities. We have developed a new class of detectors with just such properties, capitalizing not only on the rapid onset of photoconductivity but also on its potential for rapid decay.

(I point out immediately that our photoconductor radiation detectors do not count individual quanta of radiation nor, per se, provide information about the energies of the quanta. They are thus no substitutes for conventional semiconductor radiation detectors, such as lithium-doped germanium or silicon junction detectors and silicon surface-barrier detectors.)

The response time of a radiation detector is a measure of how well it can resolve rapid variations in intensity; it may be defined as the full width at half maximum of the current pulse induced in the detector by a very short radiation pulse. The response time of a conventional semiconductor radiation detector is shortened by decreasing the distance between the electrical contacts and thus the transit time for carriers. To prevent electrical breakdown, the decrease in contact spacing is accompanied by a corresponding decrease in applied voltage. But since the applied voltage and the magnitude of the current through the detector are directly related, a decrease in applied voltage produces a decrease in sensitivity (ratio of output signal to radiation intensity). Therefore short response time and high sensitivity are incompatible goals for a conventional semiconductor radiation detector. In contrast, the response time and sensitivity of a photoconductor radiation detector are much less closely coupled.

A photoconductor radiation detector is even simpler in design than a photoconductor power switch, since the radiation being studied replaces a laser as the carrier-excitation agent. In essence the detector consists of a small volume of photoconductive material (Fig. 5) with contacts to a voltage source



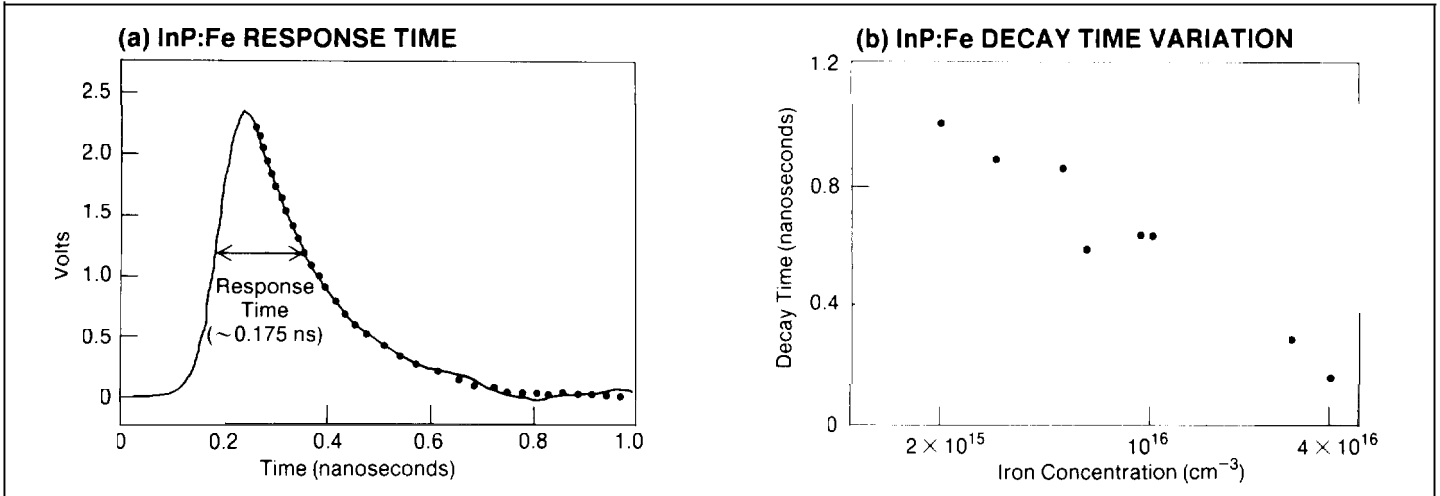

**Fig. 6. (a) Results of a response-time measurement on one of a series of iron-doped iridium phosphide detectors. The detector was activated by a 15-picosecond laser pulse; the resulting voltage pulse was measured with a sampling oscilloscope. Both the circuit-limited rise time and the decay time of the car-**

**riers contribute to the response time. (The decay time, a component of the carrier lifetime, is a measure of the rate at which electrons are removed from the conduction band by being trapped at iron sites. Recombination occurs when a trapped electron and a hole annihilate.) The decay of the pulse was fitted**

**with an exponential (solid circles) corresponding to a decay time of 155 picoseconds. (b) The decay time, and hence the response time, decreases with iron concentration. However, decay times less than about 100 picosecond cannot be attained because of the limited volatility of iron in iridium phosphide.**

cilloscope, for recording the photocurrent, which is a measure of the intensity of the radiation. The photoconductive material is integrated into a coaxial or microstrip transmission line, just as it is in the photoconductor power switch.

The key to a short response time for the detector is a short carrier lifetime. As mentioned above, the lifetime of carriers in a crystalline photoconductor can be reduced by introducing impurities or defects into the crystal lattice. The challenge is to achieve a suitably short lifetime without unduly decreasing the resistivity or carrier mobility, both of which should be as high as possible. Another desirable property of the photoconductive material is a linear variation of photocurrent with radiation intensity (that is, a constant sensitivity), since a nonlinear variation complicates analysis of the data,

We considered a number of photoconductive materials and found two with an attractive combination of lifetime, resistivity, and mobility: iron-

doped iridium phosphide (InP:Fe) and neutron-damaged gallium arsenide. Of these materials we have investigated InP:Fe the most extensively, both in laboratory experiments and in the field.

Using a variety of pulsed radiation sources, we measured the response times and sensitivities of a number of InP:Fe detectors and found them to be superior to those of other fast detectors, such as photodiodes or Compton-electron detectors. The detectors were fabricated from semi-insulating iridium phosphide containing concentrations of iron ranging from  $0.2 \times 10^{16}$  to  $4 \times 10^{16}$  atoms per cubic centimeter. The sensitivity of the detectors to gamma rays is about  $10^{-8}$  coulombs per rad for radiation events lasting less than about 10 nanoseconds. (For longer radiation events the photocurrent varies nonlinearly with radiation intensity.) The response time of the InP:Fe detectors (Fig. 6) decreases with increasing iron concentration, but unfortunately the solubility of iron in indium phos-

phide imposes a lower limit on the response time of about 100 picosecond.

InP:Fe detectors can detect and image gamma rays, hard and soft x rays, and charged and neutral particles. (Neutrons, however, must be converted to protons before being detected.) The response of InP:Fe to soft x rays (those with energies less than a few keV) is surprising because radiation of that type has such a short absorption depth (about 10 nanometers) that it does not penetrate beyond an inactive layer present on the surface of most materials. This unusual feature of InP:Fe suggested the possibility of its application to diagnostic measurements on beams of synchrotrons radiation, which are used for basic research in, for example, plasma physics and for high-resolution lithography. We tested this possibility by evaluating the performance of the detectors at the Stanford Synchrotrons Radiation Laboratory. Our initial studies indicated that the sensitivity of the detectors to x rays was constant over

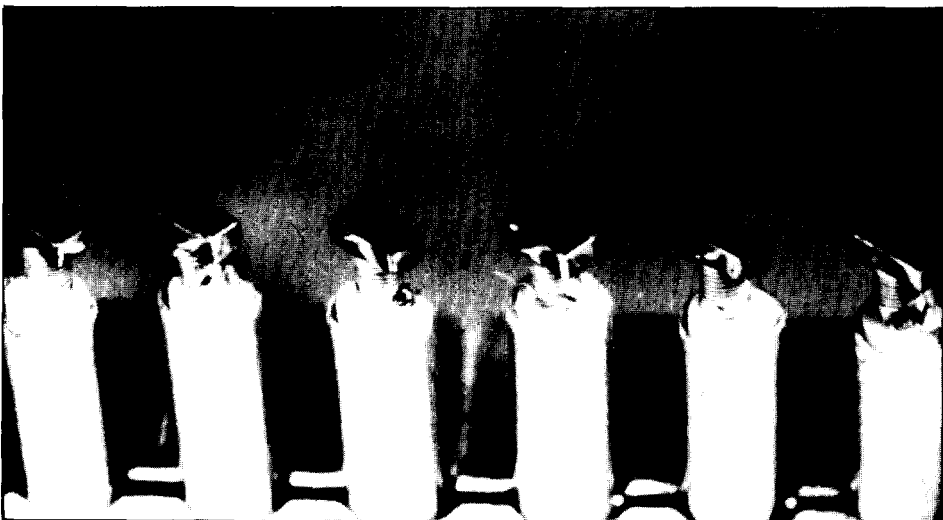
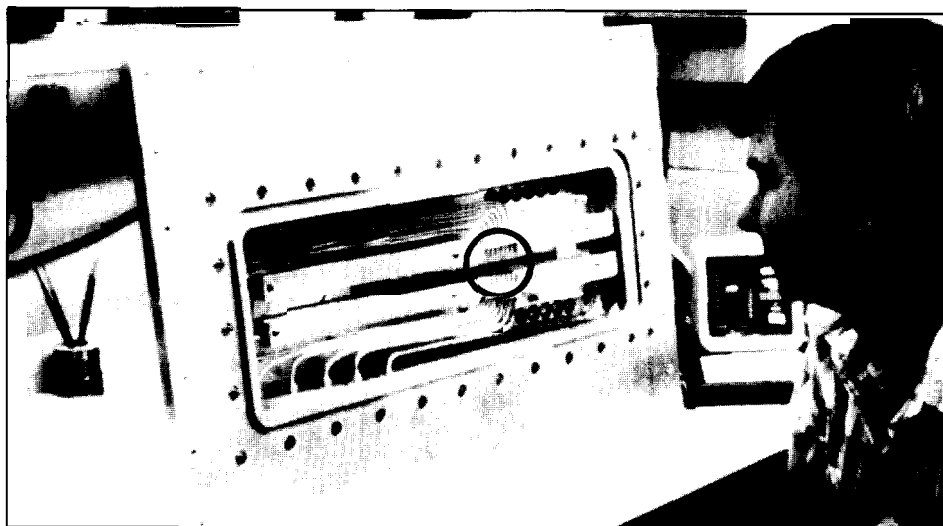

Fig. 7. A charged-particle spectrometer composed of an array of InP:Fe radiation detectors. The close-up shows the individual detectors. An electromagnet (not pictured) deflects particles with different energies to different elements of the array. Such spectrometers have provided time- and energy-resolved images of the radiation produced by nuclear weapons. ◀

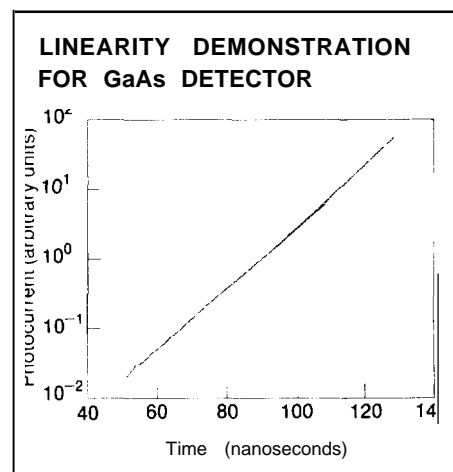

Fig. 8. This graph depicts the photocurrent generated by a gallium arsenide detector when exposed to a radiation source whose intensity varies exponentially with time. Note the nearly perfect linearity over an intensity range of  $10^4$ . Such linearity is a very desirable feature of a radiation detector. A

the energy range 0.2 to 3 keV. More recently we have found that InP:Fe is uniformly sensitive to all x-ray photons. In contrast, the sensitivity of the vacuum photodiodes commonly used for beam diagnostics decreases with x-ray energy.

We have also developed charged-particle spectrometers in which particles with different energies are deflected by a magnetic field to different elements of an array of InP:Fe detectors (Fig. 7). Such spectrometers provide time- and energy-resolved images of radiation events.

Our InP:Fe detectors have proved their worth during tests of nuclear weapons at the Nevada Test Site by supplying previously inaccessible information. In addition, they hold promise of permitting a much wider variety of diagnostic experiments. The Naval Surface Weapons Center at White Oak, Maryland, also has used our InP:Fe detectors in the field for diagnostic measurements on the bremsstrahlung from pulsed electron beams that simulate the effects of nuclear weapons.

Our development efforts on photoconductor radiation detectors have concen-

trated recently on neutron-damaged gallium arsenide, a material that offers two major advantages over InP:Fe. First, its response time, which is not subject to a solubility limit, can be as short as 1 picosecond. Second, its sensitivity, which is similar in magnitude to that of InP:Fe, is constant over an exceptionally wide range of intensities (Fig. 8) and for radiation events lasting as long as about 100 nanoseconds.

Undoubtedly, other applications, and other materials with properties specific to those applications, will be found for this new class of detectors.

## Ultrafast Electrical Measurement Device

The first integrated circuit, demonstrated in 1958, contained five components (a transistor, a capacitor, and three resistors) fashioned by modifying the electrical properties of discrete regions within a chip of semiconducting material no larger than a match. Today a chip of similar size contains millions of components. Such astounding densities—and the resulting signal speed—are the basis for many electronic marvels, including the single-chip computer microprocessor.

However, to take full advantage of the speed possible now, and even greater speed promised in the future, circuit designers need a new body of information: the response of components to signals within times as short as a few picoseconds. (The term 'response' here refers to the amplitude and phase changes effected in an electrical signal by a component.) This information is lacking because no measuring device with sufficient temporal resolution has been available. (The temporal resolution of a sampling oscilloscope, for example, is at best about 25 picoseconds, being limited by the on time of its sampling gate and by jitter in the timing of its pulse generator and sampling gate.)

Building on early ideas of D. H. Auston, we have now demonstrated that the missing information can be provided by a new device composed of two photoconductive circuit elements, one serving as a pulse generator and the other as a sampling gate, both fashioned on chip and activated by subpicosecond laser pulses (see "The World's Fastest Laser Oscillator"). The most significant feature of the new device is the generation and sampling of high-frequency signals *on chip*, that is, *within* the circuit containing the component being tested. This feature eliminates two formidable tasks: the transport of high-frequency signals into the circuit from an external generator and their transport out

*continued on page 60*

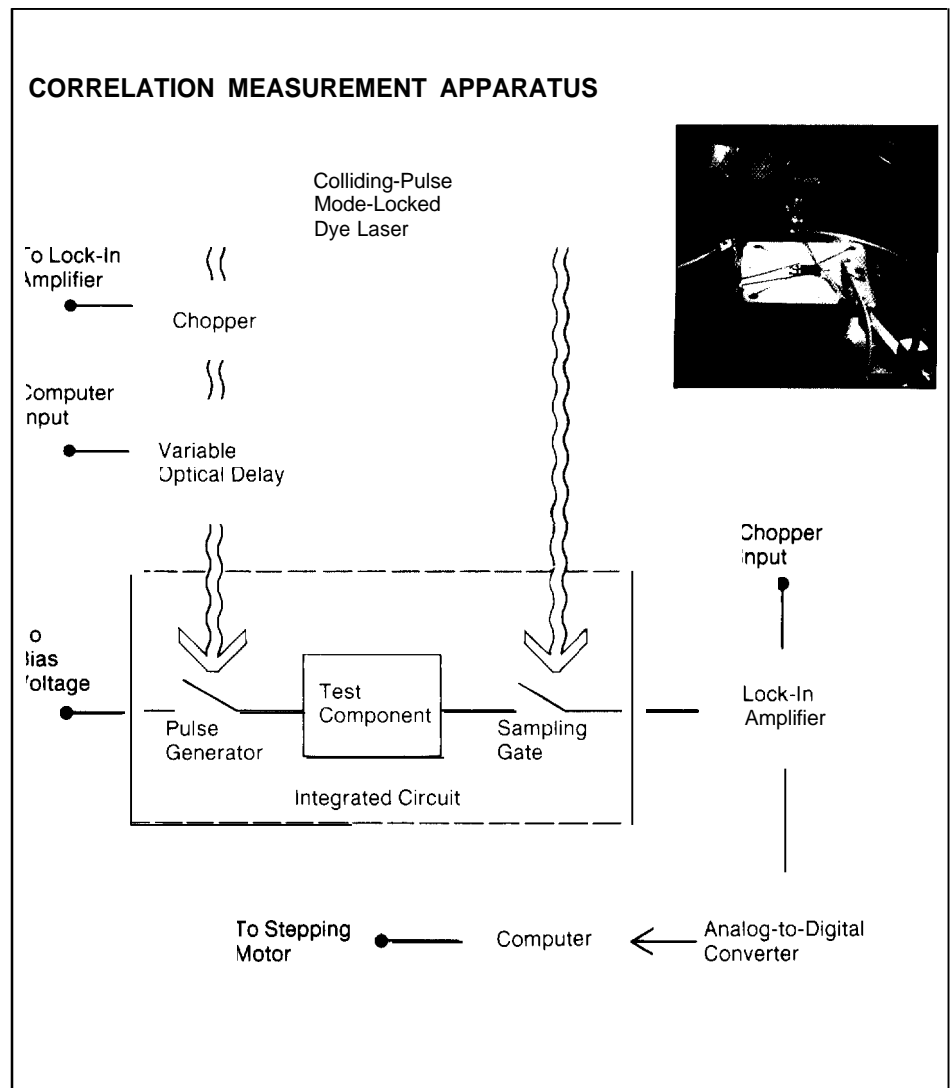
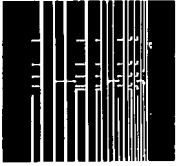

Fig. 9. Schematic diagram of an experimental setup for determining the response of an integrated-circuit component with photoconductive circuit elements (a pulse generator and a sampling gate) fabricated on chip (that is, as an integral part of the circuit). The laser produces two synchronous trains of subpicosecond pulses, one of which activates the biased pulse generator and the other the sampling gate. The pulse generator produces a current pulse, which propagates through and is modified by the component being investigated. The sampling gate feeds the modified current pulse to the lock-in amplifier during an interval (the sampling aperture) that is short compared to the duration of the pulse. The amplifier measures the average amplitude of the current pulse during that interval, which corresponds to a certain small portion of the pulse cycle. The relative timing of the pulse generator and the sampling gate is then varied (by varying the path length of one laser pulse train with a

corner reflecting cube mounted on a stepping-motor driven stage), and the amplitude measurement is repeated. The result is an amplitude versus delay curve (a correlation function) from which the response of the component can be extracted. The mechanical chopper increases the signal-to-noise ratio of the amplitude measurements by imposing a frequency of 808 hertz on the laser pulse train that activates the pulse generator. The insert is a photograph of the platform built to facilitate the correlation function measurements. The integrated circuit containing the component being investigated is mounted in the center of the platform, the two laser pulse trains are focused onto the photoconductive circuit elements through two microscope objective lenses (one of which is visible at the top of the photograph), and three coaxial probes (extending from brass holders) couple the bias voltage to the pulse generator and the signals from the sampling gate to the lock-in amplifier.



# The World's Fastest Laser Oscillator

**H**ow short an electrical pulse can be generated by a photoconductor in response to an optical pulse? This question has fundamental significance as well as practical implications. Obtaining the answer requires that the photoconductor be excited by an optical pulse whose duration is short compared to the time scale of carrier decay. Optical pulses of the requisite brevity are produced by a laser first demonstrated in 1981 by R. L. Fork, B. I. Greene, and C. V. Shank of Bell Telephone Laboratories. This so-called CPM (for colliding-pulse mode-locked) laser is illustrated schematically in the accompanying figure, and the accompanying photograph shows the CPM laser built for our research on ultrafast photoconductive circuit elements.

The lasing medium (an organic dye, rhodamine 6-G) is pumped by a continuous-wave argon-ion laser. Pulses of light from the lasing dye travel in both directions through the laser cavity along a roughly triangular path that includes a saturable absorber (another organic dye, 3,3'-diethyloxadicyanone iodide). Interaction of the counterpropagating pulses with the saturable absorber causes a locking in phase of many resonant cavity modes (mode locking). The result is a succession of relatively high-intensity pulses separated by the time required for light to traverse the cavity (about 10 nanoseconds). Two synchronous trains of pulses are extracted from the cavity through the output coupling mirror.

The first CPM laser produced 0.09-picosecond pulses; later versions with prisms in the cavity to compensate for

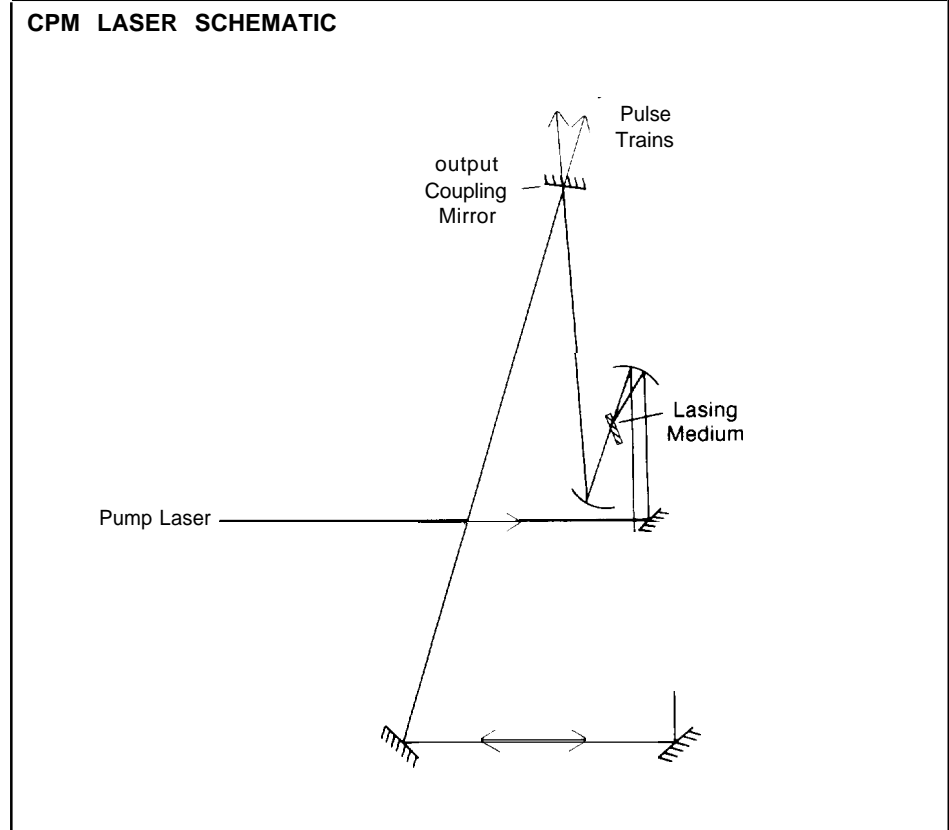

**Schematic diagram of a CPM laser. The focusing mirrors for the lasing medium and the saturable absorber have radii of**

**about 10 and 5 centimeters, respectively. The overall cavity length is about 300 centimeters.**

dispersion from the laser mirrors have produced 0.027-picosecond pulses—the shortest available today.

A natural question to ask is how the duration of such short pulses can be determined. The standard technique is one known as autocorrelation by second-harmonic generation. A beam of pulses from

the laser is split by a beam splitter, one of the resulting beams is fed through a variable optical delay, and both **are then** focused on a potassium dihydrogen phosphate (KDP) crystal. Nonlinear interaction of two out-of-phase but otherwise identical pulses produces a second harmonic whose maximum amplitude is a

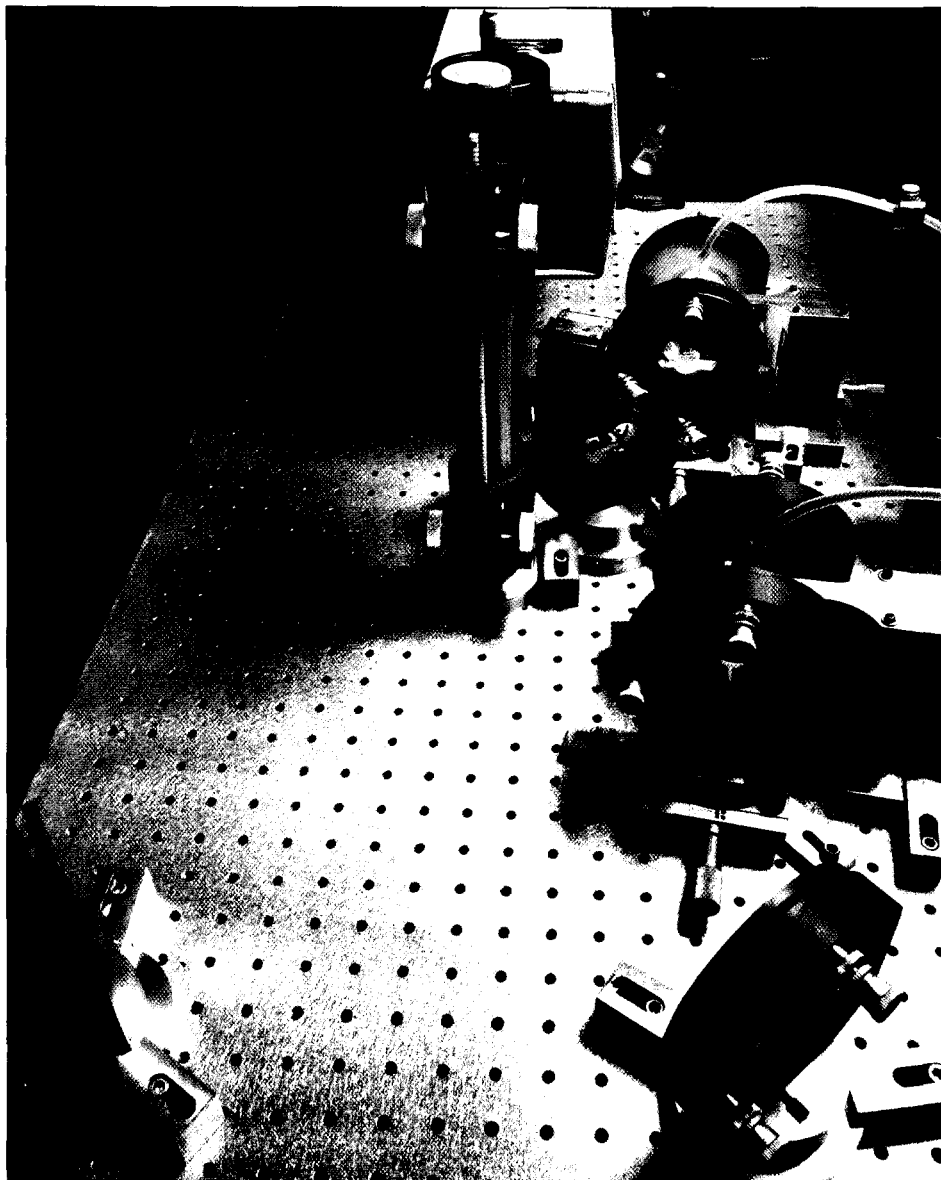

Photograph of the CPM laser built by the Laboratory's Electronic Research and Exploratory Development Group. The lasing medium (yellow) and the

saturable absorber (purple) circulate through the tubes at the right, the pump laser is visible at the top, and the output coupling mirror is in the far background.

function of the delay between the two original pulses. Measurement of that amplitude as the delay is varied yields a correlation function (an autocorrelation function, since the two pulses are identical) from which the duration of the pulses is derived. This technique is analogous to

that by which the response of an integrated-circuit component is determined from measurements of signal amplitude versus the delay between activation of a photoconductive pulse generator and a photoconductive sampling gate (see main text). ■

*continued from page 58*

of the circuit to an external sampling instrument. These tasks have in fact proved nearly impossible for signals with frequencies above about 25 gigahertz. (Frequency-domain measurements with a 3-decibel bandwidth of about 25 gigahertz correspond to time-domain measurements with a resolution of about 15 picoseconds.)

Figure 9 shows schematically an experimental setup for investigating a circuit component with the device. Its operation is in many respects similar to that of a sampling oscilloscope. Briefly, a laser pulse induces the biased pulse generator to produce an electrical signal. This signal passes through the component, being modified in the process by its response. The sampling gate, activated by a second laser pulse, feeds the signal during a short interval (the sampling aperture\*) to external circuitry that measures its average amplitude during that interval. By varying the relative timing of the two laser pulses, an amplitude versus delay curve known as a correlation function is obtained. Embedded within this correlation function is the response of the component, together with the responses of the pulse generator, the sampling gate, and the interconnections. Extracting the component response requires knowledge or reasonable estimates of the other responses.

The temporal resolution of the device is determined by the sampling aperture, which in turn is determined by the lifetime of carriers in the sampling gate. Thus short carrier lifetime is the key property for the sampling gate, just as it is for the photoconductor radiation detector. In addition, the material composing both photoconductive circuit elements should have high resistivity and high carrier mobility. Furthermore, for greatest utility

*\*The sampling aperture of a photoconductive sampling gate is defined as the, full width at half maximum of the pulse induced in the gate by an ultrashort optical pulse. It is essentially identical to the property defined in detector parlance as response time.*

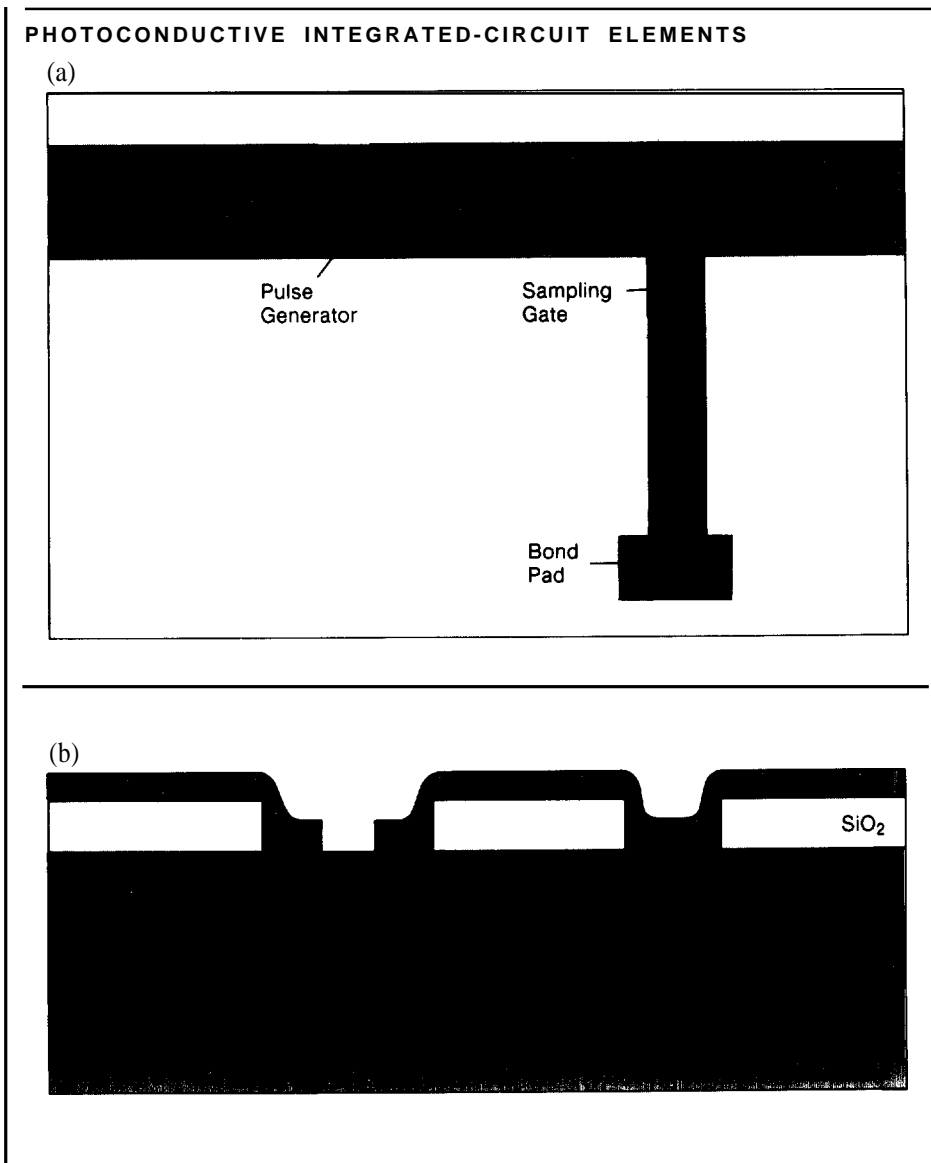

**Fig. 10.** (a) Top view (schematic) of a portion of the silicon integrated circuit used to determine the characteristics of photoconductive circuit elements (pulse generators and sampling gates) fabricated within the silicon substrate. The pulse generator and sampling gate consist of gaps (red) in the field oxide (gray) covering the silicon substrate. Aluminum microstrip transmission lines (blue) connect the pulse generator and sampling gate to other portions of the

circuit. Areas where the aluminum lines contact the silicon substrate are hatched. Signals are extracted through the bond pad (black) for amplitude measurements. (b) A cross-sectional view of one of the photoconductive circuit elements. Photoconductive circuit elements can also be fabricated within a layer of polycrystalline silicon on a silicon substrate and within the substrate employed for gallium arsenide integrated circuits.

the device should be realizable within both silicon and gallium arsenide integrated circuits (that is, on substrates of both crystalline silicon and crystalline gallium arsenide). Therefore the necessary properties must be achieved in a material and by methods compatible with the technology of fabricating those types of integrated circuits. (Silicon integrated circuits dominate the industry, but the more advanced gallium arsenide circuits are in greater need of ultrafast measurements.) Finally, the material must be a very efficient photoconductor, capable of transforming the relatively low (about 50-picojoule) energy content of subpicosecond laser pulses to electrical pulses of relatively high amplitude.

**Silicon Measurement Device.** We first investigated the possibility of using crystalline silicon, the substrate for silicon integrated circuits, as the material for the photoconductive circuit elements. We fabricated a number of 'integrated circuits' on a typical silicon substrate, each circuit consisting simply of an aluminum interconnection line in contact, through holes in the field oxide (silicon dioxide) covering the substrate, to regions of the substrate that were to serve as the pulse generator and sampling gate (Fig. 10). The sampling-gate region (and sometimes also the pulse-generator region) were bombarded with various ions (deuterium, helium, neon, or oxygen) to decrease carrier lifetime.

Figure 11 shows the correlation function obtained for one of the test devices. Since the interconnection has very little effect on the signal issuing from the pulse generator, the correlation function provides a very close approximation to the response of the device itself (that is, the response of the pulse generator to the laser pulse and of the sampling gate to the resulting electrical pulse), which in turn provides the rise time of the pulse generator and the sampling aperture, of the sampling gate. The shortest sampling aperture obtained with our early test de-

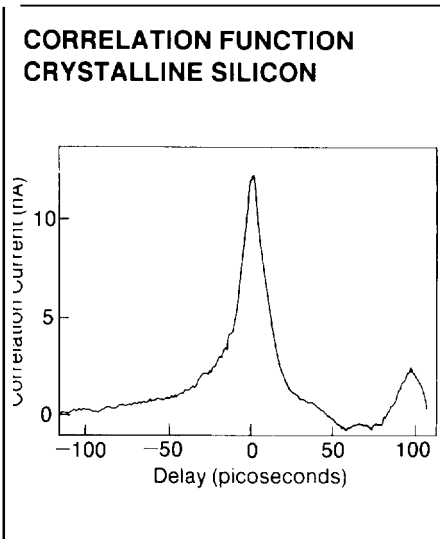

Fig. 11. This correlation function for a photoconductive pulse generator and sampling gate, both of crystalline silicon damaged with 30-MeV oxygen ions, was obtained with the experimental setup of Fig. 9. The left and right portions of the correlation function are dominated, respectively, by the rise time of the pulse generator and the lifetime of carriers in the sampling gate. Analysis of the correlation function yields a rise time (10 to 90 percent) for the pulse generator of about 5 picosecond and a sampling aperture for the sampling gate of about 20 picosecond. The small peak on the right is due to reflections from the bond pads at the ends of the microstrip transmission line. ◀

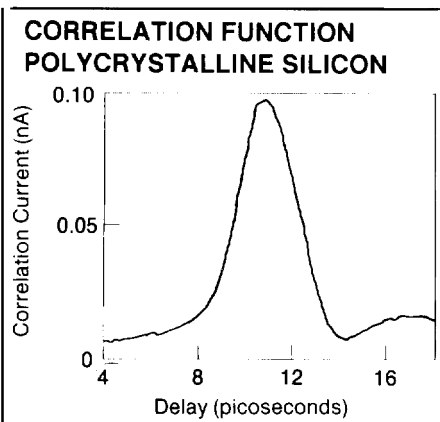

Fig. 12. Analysis of this correlation function for a photoconductive pulse generator and sampling gate, both of polycrystalline silicon damaged with 250-keV silicon ions, yields a sampling aperture of about 2 picosecond, which is considerably shorter than the sampling aperture attainable with crystalline silicon. Such a short sampling aperture implies that the performance of the electrical measurement device is limited by the capacitances of the sampling gate and the pulse generator rather than by carrier lifetime. ◀

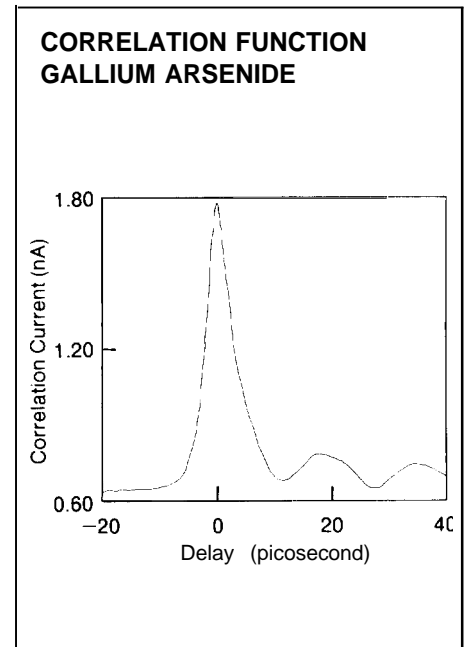

Fig. 13. Analysis of this correlation function for a photoconductive pulse generator and sampling gate, both of gallium arsenide damaged with 6-MeV alpha particles, yields a sampling aperture of about 1 picosecond, the shortest we have attained. A measuring device with such a short sampling aperture is required to determine the response of gallium arsenide components for advanced integrated circuits. ▶

vices was about 20 picosecond; by increasing the amount of radiation damage, we have since produced crystalline silicon sampling gates with sampling apertures of about 12 picosecond. All the devices exhibited pulse rise times of about 5 picosecond.

Our experiments with photoconductive circuit elements of crystalline silicon proved the principle of the device but also revealed a major disadvantage of that material. We found that the bombarding ions must penetrate much farther into the silicon than do the laser pulses. Otherwise, carriers created at depths below the extent of the radiation damage are long-lived,

and these long-lived carriers, which are not electrically isolated from the radiation-damaged region, make the device worthless. Sufficiently deep radiation damage can be produced only by ions with energies much greater than the few hundred keV provided by the ion implanters available to the integrated-circuit industry.

To eliminate the need for deep radiation damage, we searched among the other materials found in silicon integrated circuits for one that could be electrically isolated from the silicon substrate. Polycrystalline silicon, a material used for interconnections and the gate electrodes of

field-effect transistors, seemed a likely candidate. It can be isolated from the substrate by the field oxide, its intrinsic resistivity is reasonably high, and we found that the carrier mobility could be increased to an acceptable value by annealing at 1100°C. (Annealing increases the sizes of crystal grains in the material and thus reduces the grain-boundary scattering that limits carrier mobility in normal polycrystalline silicon.)

Figure 12 shows a correlation function for a test device containing photoconductive circuit elements of polycrystalline silicon. The sampling aperture of the device is so short (about 2 picosecond) that

it is limited not by carrier lifetime but by the capacitances of the photoconductive gaps. The temporal resolution of such a device exceeds that of sampling oscilloscopes by a factor of about 10.

We are pursuing several near-term applications of the polycrystalline silicon device, at present concentrating on its use to measure the velocity, attenuation, and dispersion of high-frequency signals as they propagate through various microstrip transmission lines on silicon substrates. (The opening figure shows an integrated circuit fabricated for this purpose.) The high accuracy of these measurements, made possible by the performance characteristics of the device coupled with essentially zero timing jitter, will permit us to verify the predictions of a model we had developed earlier for the transmission

characteristics of such interconnections. (Another aspect of our research is the development of models for use in computer-aided circuit design that more adequately describe today's high-speed integrated circuits. For example, interconnections are commonly modeled as lumped circuit elements, but that approach is valid only when the wavelengths of the signals being transmitted are small compared with the dimensions of the interconnections.) Early

results indicate that the model predicts propagation velocity with an accuracy of 1 percent and attenuation and dispersion with an accuracy of 10 percent.

Gallium Arsenide Measurement Device. The near monopoly of silicon as the substrate material for integrated circuits is now being broken by gallium arsenide, which offers two major advantages over silicon. First, lasers and other light-emit-

overshoot is expected; at high fields the overshoot, although large in magnitude, is so short in duration that it is obscured by the  $RC$  time constant of the photoconductive gaps; and at intermediate fields the overshoot, although smaller in magnitude, is sufficiently long to be resolvedly

Fig. 15. These data for the current induced in a gallium arsenide pulse generator by 0.17-picosecond laser pulses represent the first direct observation of velocity overshoot. The observed dependence of the overshoot on electric field is qualitatively consistent with that predicted theoretically: at low fields no

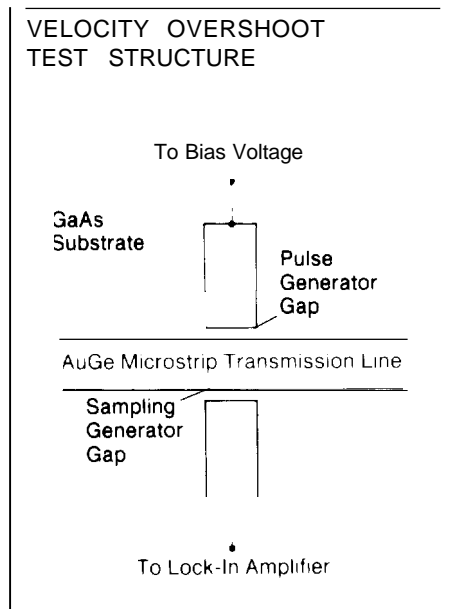
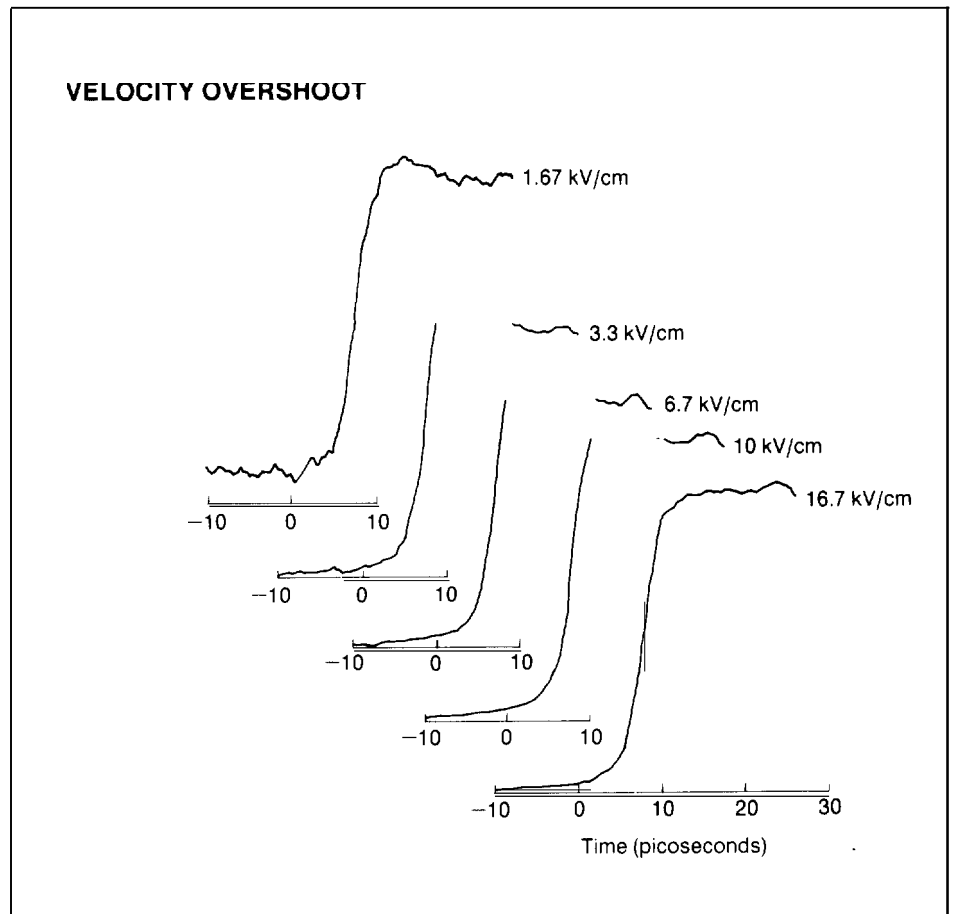
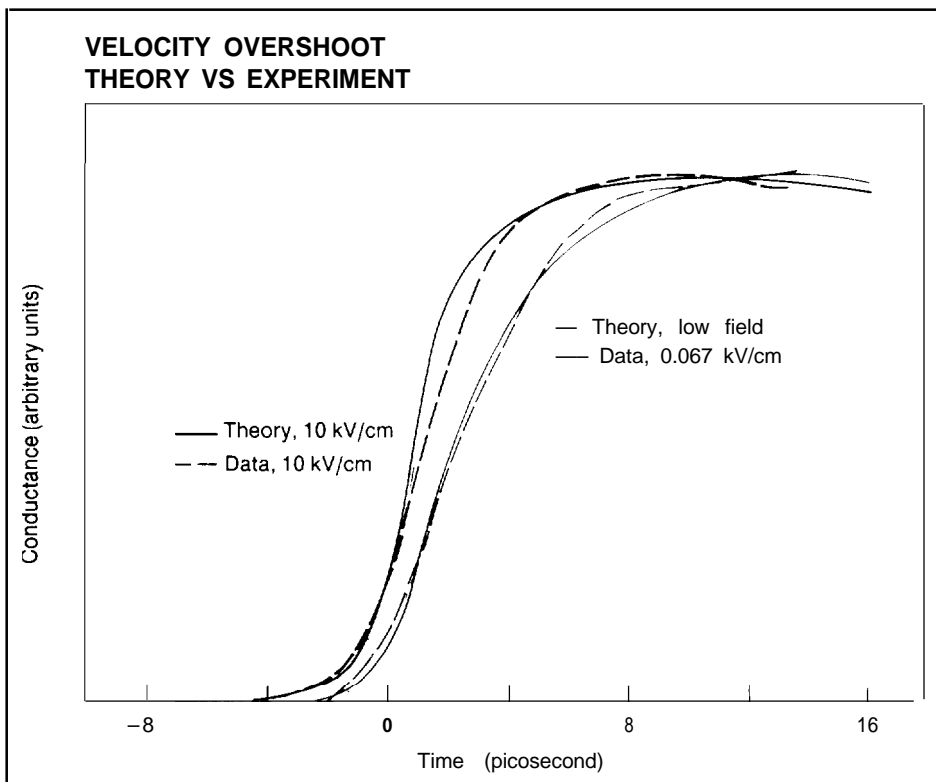

Fig. 14. Schematic diagram of a portion of the integrated circuit used to study velocity overshoot in gallium arsenide. The photoconductive pulse generator and sampling gate consist of gaps, patterned by lift-off photolithography, between the microstrip transmission lines. Gold metallization on the backside of the gallium arsenide substrate served as a backplane.







**Fig 16. A convolution of the predicted velocity overshoot with the  $RC$  time constants of the photoconductive gaps yields very good quantitative agreement between the observed and calculated values for the conductance of a gallium**

**arsenide pulse generator excited by 0.17-picosecond laser pulses. The much greater magnitude of the overshoot in high electric fields causes a steeper and earlier rise of the conductance.**

ting devices can be fabricated within gallium arsenide, and second, gallium arsenide transistors are several times faster than silicon transistors. (Silicon's indirect band gap prevents it from lasing, and its lower carrier mobility decreases transistor speed.) These advantages imply that gallium arsenide integrated circuits will become increasingly common, and we have expended substantial effort on realizing ultrafast photoconductors within gallium arsenide substrates.

Correlation functions for early test devices fabricated on gallium arsenide substrates showed that the sampling aperture was limited by the  $RC$  time constants of the photoconductive gaps. Thinning the substrate, a usual method of re-

ducing this limitation, proved extremely difficult, but replacing the microstrip transmission line with a coplanar waveguide transmission line yielded extraordinarily short sampling apertures—less than 1 picosecond (Fig. 13).

We have applied a gallium arsenide device to measuring the step response of a gallium arsenide transistor. The resolution of this measurement, 11 picoseconds, was, at the time, the highest ever achieved,

**Velocity Overshoot.** Our work on gallium arsenide circuit elements also provided the first direct observation of 'velocity overshoot.' This phenomenon, predicted theoretically in 1972 and eagerly sought ever since, is a transient accelera-

tion of carriers, in a constant electric field, to velocities above the steady-state drift velocity. Velocity overshoot is of great technological interest because it could be the basis for very-high-speed transistors, provided the transistors were appropriately small.

Using the integrated circuit shown schematically in Fig. 14, we measured the current generated by a gallium arsenide photoconductor in response to 0.17-picosecond laser pulses. Early results (Fig. 15) were qualitatively consistent with the predicted dependence on electric field of the duration and magnitude of the velocity overshoot. By increasing the uniformity of the electric field imposed on the photoconductor (with improved contacts), we obtained further data that are in excellent *quantitative* agreement with theory (Fig. 16). These experiments not only proved the reality of velocity overshoot but also demonstrated that photoconductive circuit elements can be used to study the phenomenon, paving the way to its utilization in components for advanced integrated circuits.

## Summary

This article has highlighted new devices made possible by the rapid onset and decay of photoconductivity. However, one goal of our efforts here at the Laboratory does not concern the devices themselves and their immediate practical benefits. Rather, development of the devices, in particular the photoconductive circuit elements, is a necessary first step toward new avenues of basic research on semiconductors. Our observation of velocity overshoot in gallium arsenide is an example of such research. The effect, one of a class known as nonequilibrium carrier-transport phenomena, is due to collisions of carriers with the vibrating crystal lattice. The mean time between collisions ranges from a few femtoseconds to a few picoseconds. It is that world of 'fleeting events we aim to explore. ■

## Acknowledgments

Many others contributed to the success of the work described in this article. The author wishes in particular to acknowledge the collaboration of Jeffrey M. Bradley, Alan J. Gibbs, A. Evan Iverson, Donald R. Kania, Nicholas G. Paulter, Darryl L. Smith, and Ronald S. Wagner of Los Alamos, Douglas R. Bowman of the U.S. Military Academy at West Point (formerly of Stanford University), Robert W. Dutton of Stanford University, William R. Eisenstadt of the University of Florida (formerly of Stanford University), F. A. Lindholm of the University of Florida, and William C. Nunnally of the University of Texas, Arlington (formerly of Los Alamos).

## Further Reading

### General

D. H. Auston. 1975. Picosecond optoelectronic switching and gating in silicon. *Applied Physics Letters* 26:101-103.

D. H. Auston, A. M. Johnson, P. R. Smith, and J. C. Bean. 1980. Picosecond optoelectronic detection, sampling, and correlation measurements in amorphous semiconductors. *Applied Physics Letters* 37:371-373.

Gerard Mourou, editor. *Picosecond Optoelectronics*. Volume 439 of *Proceedings of SPIE*. Bellingham, Washington: The Society of Photo Optical Instrumentation Engineers, 1983.

D. H. Auston and K. B. Eisenthal, editors. *Ultrafast Phenomena IV: Proceedings of the Fourth International Conference, Monterey, California, June 11-15, 1984*. Berlin: Springer-Verlag, 1984.

G. A. Mourou, D. M. Bloom, and C.-H. Lee, editors. *Picosecond Electronics and Optoelectronics: Proceedings of the Topical Meeting, Lake Tahoe, Nevada, March 13-15, 1985*. Springer Series in Electrophysics, edited by Walter Engl, volume 21. Berlin: Springer-Verlag, 1985.

### Photoconductor Power Switch

W. C. Nunnally and R. B. Hammond. 1984.80-

MW photoconductor power switch. *Applied Physics Letters* 44:980-982.

W. C. Nunnally and R. B. Hammond. Optoelectronic switch for pulsed power. In *Picosecond Optoelectronic Devices*, edited by Chi H. Lee. Orlando, Florida: Academic Press, Inc., 1984.

R. B. Hammond. Photoconductor switching: Some physical mechanisms. In *Final Report of the Workshop on New Directions in Solid State Power Switches*, Weber Research Institute, Polytechnic Institute of New York, Farmingdale, New York, August 28-30, 1985, pp. 239-285. B. Senitzky, chairman. Washington, D. C.: Office of Naval Research, 1985.

### Photoconductor Radiation Detector

Robert B. Hammond, Nicholas G. Paulter, Ronald S. Wagner, Thomas E. Springer, and Martin D. J. MacRoberts. 1983. InP:Fe photoconductors as photodetectors. *IEEE Transactions on Electron Devices* ED-30:412-415.

R. B. Hammond, N. G. Paulter, R. S. Wagner, and T. E. Springer. 1984. Excitation and Fe concentration dependence in the impulse photoconductance of InP:Fe. *Applied Physics Letters* 44:620-622.

D. R. Kania, R. J. Bartlett, R. S. Wagner, R. B. Hammond, and P. Pianetta. 1984. Pulsed soft x-ray response of InP:Fe photoconductors. *Applied Physics Letters* 44:1059-1061.

Ronald S. Wagner, Jeffrey M. Bradley, and Robert B. Hammond. 1986. Picosecond photoconductors as radiation detectors. *ZEEE Transactions on Nuclear Science* NS-33: 250-253.

D. R. Kania, A. E. Iverson, D. L. Smith, R. S. Wagner, R. B. Hammond, and K. A. Stetler. Flat-response detectors for the vacuum ultraviolet and soft x-ray region. Accepted for publication in *Journal of Applied Physics*.

### Electrical Measurement Device

R. B. Hammond, N. G. Paulter, and R. S. Wagner. 1984. Observed circuit limits to time resolution in correlation measurements with Si-on-sapphire, GaAs, and InP picosecond photoconductors. *Applied Physics Letters* 45:289-291.

D. R. Bowman, R. B. Hammond, and R. W. Dutton. 1985. Polycrystalline-silicon integrated photoconductors for picosecond pulsing and gating. *IEEE Electron Device Letters* EDL-6:502-504.

D. R. Bowman, R. W. Dutton, and R. B. Hammond. 1985. New integrated polysilicon photoconductor for ultrafast measurements on silicon. In *Technical Digest of the International Electron Devices Meeting, Washington, DC, December 1-4, 1985*, pp. 117-120. New York: Electron Devices Society of IEEE, 1985.

R. B. Hammond. 1985. Electron-velocity overshoot observed in an impulse-excited GaAs photoconductor. *Physica* 134B:475-479.

R. B. Hammond and N. M. Johnson. 1986. Impulse photoconductance of thin-film polycrystalline silicon. *Journal of Applied Physics* 59:3155-3159.

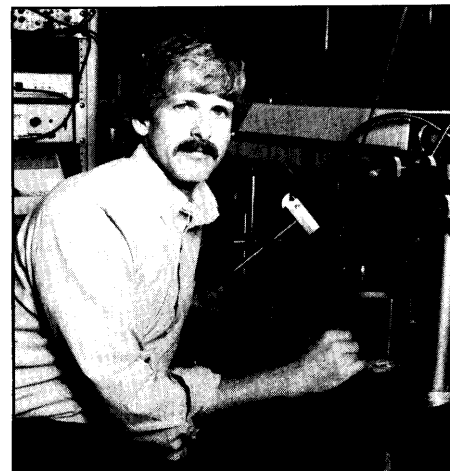

**Robert B. Hammond** received his scientific education at the California Institute of Technology, earning a B.S. in physics (with honor) in 1971, an M.S. in applied physics a year later, and a Ph.D. in applied physics in 1975. Since 1973 his research has focused on experimental and theoretical aspects of semiconductor physics. In 1975 he joined the Air Force Weapons Laboratory in Albuquerque, New Mexico, where he helped develop a chemically pumped iodine laser. In 1976 he joined the Electronics Division at Los Alamos. His work here has included development of a position-sensitive detector for infrared lasers and of a high-damage-threshold Smartt interferometer for pulsed infrared lasers, measurement of the phase diagram for the electron-hole liquid in silicon, experimental and theoretical studies of exciton kinetics in silicon, and passivation studies of III-V semiconductors. Since 1981 his attention has been devoted primarily to the topics reported on in this article. He has authored over fifty technical papers and is a member of the American Physical Society, the Institute of Electrical and Electronics Engineers, the Optical Society of America, Sigma Xi, and the Bohmische Physical Society.